



Read this Owner's Manual thoroughly before operating the equipment. Keep it with the equipment at all times. Replacements are available from Thern, Inc., PO Box 347, Winona, MN 55987, 507-454-2996. www.thern.com

IMPORTANT: Please record product information on page 2. This information is required when calling the factory for service.



Owner's Manual

For Model RW50

Cable Wind-Up Spool

Two-Year Limited Warranty

Please record the following:

Date Purchased: _____

Model No.: _____

Code No.: _____

This information is required when calling the factory for service.

Thern, Inc. warrants its products against defects in material or workmanship for two years from the date of purchase by the original using buyer, or if this date cannot be established, the date the product was sold by Thern, Inc. to the dealer. To make a claim under this warranty, contact the factory for an RGA number. The product must be returned, prepaid, directly to Thern, Inc., 5712 Industrial Park Road, Winona, Minnesota 55987. The following information must accompany the product: the RGA number, the date of purchase, the description of the claimed defect, and a complete explanation of the circumstances involved. If the product is found to be defective, it will be repaired or replaced free of charge, and Thern, Inc. will reimburse the shipping cost within the contiguous USA.

This warranty does not cover any damage due to accident, misuse, abuse, or negligence. Any alteration, repair or modification of the product outside the Thern, Inc. factory shall void this warranty. This warranty does not cover any costs for removal of our product, downtime, or any other incidental or consequential costs or damages resulting from the claimed defects. This warranty does not cover brake discs, wire rope or other wear components, as their life is subject to use conditions which vary between applications.

FACTORY AUTHORIZED REPAIR OR REPLACEMENT AS PROVIDED UNDER THIS WARRANTY IS THE EXCLUSIVE REMEDY TO THE CONSUMER. THERN, INC. SHALL NOT BE LIABLE FOR ANY INCIDENTAL OR CONSEQUENTIAL DAMAGES FOR BREACH OF ANY EXPRESS OR IMPLIED WARRANTY ON THIS PRODUCT. EXCEPT TO THE EXTENT PROHIBITED BY APPLICABLE LAW, ANY IMPLIED WARRANTY OF MERCHANTABILITY OR FITNESS FOR A PARTICULAR PURPOSE ON THIS PRODUCT IS LIMITED IN DURATION TO THE DURATION OF THIS WARRANTY.

Some states do not allow the exclusion or limitation of incidental or consequential damages, or allow limitations on how long an implied warranty lasts, so the above limitation or exclusion may not apply to you. This warranty gives you specific legal rights, and you may also have other rights which vary from state to state.

Note: Thern, Inc. reserves the right to change the design or discontinue the production of any product without prior notice.

About This Manual

The Occupational Safety and Health Act of 1970 states that it is the employer's responsibility to provide a workplace free of hazard. To this end, all equipment should be installed, operated, and maintained in compliance with applicable trade, industrial, federal, state, and local regulations. It is the equipment owner's responsibility to obtain copies of these regulations and to determine the suitability of the equipment to its intended use.

This Owner's Manual, and warning labels attached to the equipment, are to serve as guidelines for hazard-free installation, operation, and maintenance. They should not be understood to prepare you for every possible situation.

The information contained in this manual is applicable only to the Thern Model RW50 Cable Wind-Up Spool. Do not use this manual as a source of information for any other equipment.

The following symbols are used for emphasis throughout this manual:

▲WARNING

Failure to follow 'WARNING!' instructions may result in equipment damage, property damage, and/or serious personal injury.

▲CAUTION

Failure to follow 'CAUTION!' instructions may result in equipment damage, property damage, and/or minor personal injury.

Important!

Failure to follow 'important!' instructions may result in poor performance of the equipment.

Suggestions for Safe Operation



⚠ WARNING

DO the following:

Read and comply with the guidelines set forth in this Owner's Manual. Keep this manual, and all labels attached to the winch, readable and with the equipment at all times. Contact Thern, Inc. for replacements.

Keep hands away from the drum, gears, wire rope, and other moving parts of the equipment.

DO NOT do the following:

Do not use for lifting or hoisting. This product is designed for winding up unloaded wire rope.

Do not exceed the load rating of the winch or any other component in the system. To do so could result in failure of equipment.

Do not use damaged or malfunctioning equipment. To do so could result in failure of the equipment.

Do not modify the equipment in any way. To do so could cause equipment failure.

Do not divert your attention from the operation. Stay alert to the possibility of accidents, and try to prevent them from happening.

Important!

- Inspect the winch immediately following installation according to the Instructions for Periodic Inspection. This will give you a record of the condition of the winch with which to compare future inspections.
- A qualified professional should inspect or design the foundation to insure that it will provide adequate support.

1.1 Installing the Winch

⚠ WARNING

Do not install the winch in an area defined as hazardous by the National Electric Code, unless installation in such an area has been thoroughly approved.

- 1.1.1 MAINTAIN A FLEET ANGLE between 1/2 and 1-1/2 degrees. The proper fleet angle minimizes wire rope damage by helping the wire rope wind uniformly onto the drum. See figure 1.
- 1.1.2 FASTEN THE WINCH securely to the foundation.

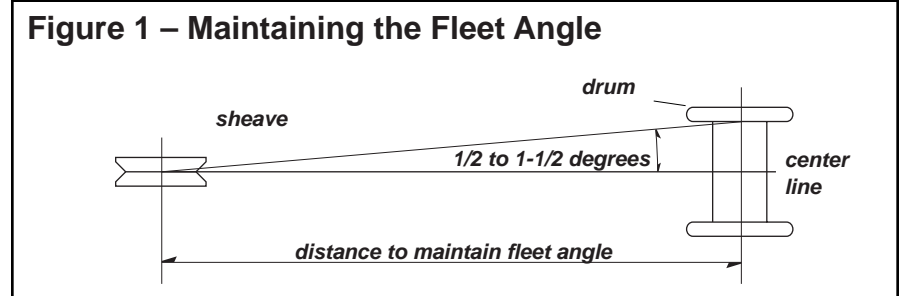

Important!

- Limit nonuniform winding by keeping tension on the wire rope and by maintaining the proper fleet angle.
- It is your responsibility to detect and account for different factors affecting the condition and performance of the equipment.

Figure 2 – Flange Clip Anchor

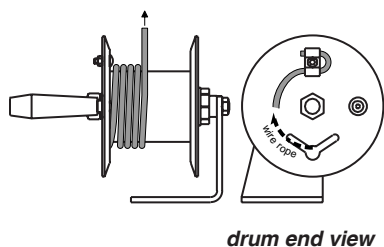

drum end view

typical installation shown

Figure 3 – Quick Disconnect Anchor

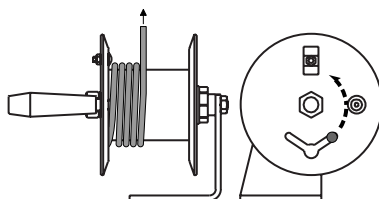

drum end view

typical installation shown

2.1 General Theory of Operation

- 2.1.1 THE PULL PLACED ON THE EQUIPMENT to must not exceed the load rating of the equipment.
- 2.1.2 THIS EQUIPMENT CAN DEVELOP FORCES that will exceed the load rating. It is the responsibility of the equipment user to limit the size of the load. Inspect the equipment regularly for damage according to the instructions contained in this manual.
- 2.1.3 DRUM CAPACITY depends on how tightly and evenly the wire rope is wound on the drum. Actual drum capacities are usually 25-30% less than values shown in performance tables, due to loose winding and overlapping.
- 2.1.4 LOAD RATING represents the maximum pull that can be placed on new equipment. Load ratings are assigned values for specific amounts of load travel or wire rope accumulation. The load rating decreases as layers of wire rope accumulate on the drum.
- 2.1.5 DUTY refers to the type of use the equipment is subject to. Consider the following when determining duty rating.
- ENVIRONMENT: harsh environments include hot, cold, dirty, wet, corrosive, or explosive surroundings. **Protect the equipment from harsh environments when possible.**
 - MAINTENANCE: poor maintenance, meaning poor cleaning, lubrication, or inspection, leads to poor operation and possible damage of the equipment. **Minimize poor maintenance by carefully following the instructions contained in this manual.**
 - FREQUENCY OF OPERATION: frequent or lengthy operations increase wear and shorten the life span of gears, bearings, and other components. **Increase maintenance of the equipment if used in frequent operations.**

CONTACT THE FACTORY FOR MORE INFORMATION.

3.1 Preparing for Operation

- 3.1.1 INSPECT THE EQUIPMENT according to the Instructions for Frequent Inspection.
- 3.1.2 ATTACH WIRE ROPE to the drum using the appropriate method. **Cable can attach to either flange, but drum winds in one direction only.**
- FLANGE CLIP ANCHOR for use with wire rope not equipped with a swaged ball. Pass the end of the wire rope through the hole in the flange, insert the carriage bolt, loop the wire rope around the bolt, install the clip so the wire rope is held in place and install the jam nut to flatten the wire rope against the drum flange. See figure 2.
 - QUICK DISCONNECT ANCHOR. Push the end stop through the large center hole in the drum flange and pull forward to lodge the end stop in the slot. See figure 3.
- 3.1.3 TURN THE HANDLE CLOCKWISE to wind wire rope onto the drum. If wire rope unwinds from the drum when the handle is rotated clockwise, the wire rope is installed incorrectly. **Install the wire rope correctly before continuing.**

Important!

- Obey a stop signal from anyone.
- Maintain tension on the wire rope to keep it tightly and evenly wound on the drum.

Figure 4 – Freewheel Adjustment

adjust drum shaft nut

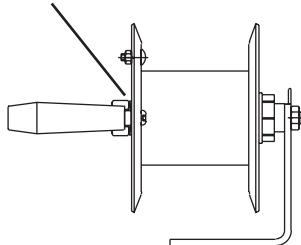

Important!

- Start an inspection program as soon as you put the equipment into use.
- Appoint a qualified person to be responsible for regularly inspecting the equipment.
- Keep written records of inspection. This allows comparison with comments from previous inspections so you can see the changes in condition or performance.

Inspect the equipment:

- Before each operation.
- Whenever you notice signs of damage or poor operation.
- Whenever you return the equipment to service from storage.
- Whenever you have, or think you may have, overloaded or shock loaded the equipment.

- 3.1.4 ENGAGE THE RATCHET when winding wire rope onto the drum, disengage the ratchet to unwind the wire rope.
 - a **DO NOT ENGAGE THE RATCHET while the gears are turning.** Stop turning the drum before engaging the ratchet.
 - b DISENGAGE THE RATCHET by turning the drum slightly to remove pressure from the ratchet, then move the ratchet spring 90 degrees.
- 3.1.5 GRIP THE HANDLE TIGHTLY at all times during operation. If you release the handle the drum may backdrive causing the handle to spin. **Do not try to stop a spinning handle, step clear until the spinning stops.**
- 3.1.6 OBSERVE THE WIRE ROPE as it winds onto the drum. If it becomes loose, uneven, or overlapped, stop the operation and rewind the wire rope before continuing. **Continued operation with overlapped or uneven wire rope can damage the wire rope and shorten its life.**
- 3.1.7 FREEWHEELING DRAG can be adjusted by tightening or loosening the drum shaft on the rotational handle side of the drum. See figure 4.

4.1 Maintenance

▲WARNING

Do not use damaged or malfunctioning equipment. Place an “OUT OF ORDER” sign on the winch. Do not use the winch until the sign is removed by a qualified maintenance person who has completely corrected the problem.

- 4.1.1 CLEAN THE EQUIPMENT every six months or whenever it is dirty. Use an oily rag to remove dirt and grease. Leave a light film of oil to protect against rust and corrosion. Wipe off excess oil to avoid the accumulation of dirt.
- 4.1.2 LUBRICATE THE EQUIPMENT at least every 6 months, by applying 2 to 3 drops of SAE 30 oil to the drum shaft. Rotate the drum several times to allow oil to penetrate, and wipe off excess oil to avoid dirt accumulation.
- 4.1.3 INSPECT THE EQUIPMENT to detect signs of damage or poor operation before they become hazardous.
 - a VISUALLY INSPECT the equipment.
 - Check all equipment for cracks, dents, bending, rust, wear, corrosion and other damage.
 - Make sure all fasteners are tightened securely.
 - Make sure the foundation is in good condition, and capable of supporting the winch and its load under all load conditions.
 - b TEST PERFORMANCE by operating the equipment.
 - Listen for unusual noises, and look for signs of damage.
 - Make sure the wire rope winds evenly and tightly onto the drum. If it is loose or uneven, rewind it before continuing.
 - Make sure the handle and drum rotate freely and smoothly.
 - Make sure the ratchet engages and disengages completely.

Completely correct all problems before continuing. Use the troubleshooting chart to help determine the cause of certain problems. See table 2.

5.1 Repair

Important!

- It is your responsibility to determine when to replace parts. When considering whether to continue using a part or to replace it, remember that replacing it is the best way to avoid further equipment damage.
- Appoint a qualified person to be responsible for all the repairs to the equipment.

- 5.1.1 GET FACTORY AUTHORIZATION for all repairs. Unauthorized repairs will void the warranty, and may lead to damage or failure of the equipment.
- 5.1.2 REPLACE DAMAGED OR POORLY OPERATING PARTS with Thern repair parts.
- 5.1.2 TO ORDER REPAIR PARTS, contact your local dealer. Include the following information when ordering.
 - model number
 - **serial number** (or code number)
 - part number
 - date purchased, and from whom
 - description of what happened, or what is wrong
 - your name and return address

damages		problems	
general	<input type="checkbox"/> parts cracked, bent, rusted, worn, otherwise damaged	<input type="checkbox"/> unusual noises, other signs of malfunction	
fasteners	<input type="checkbox"/> stripped threads, bent, worn, otherwise damaged	<input type="checkbox"/> loose, not tightened to proper torque	
drum	<input type="checkbox"/> cracked, bent, rusted worn, otherwisely damaged	<input type="checkbox"/> does not rotate freely	
ratchet	<input type="checkbox"/> cracked, bent, rusted worn, otherwisely damaged	<input type="checkbox"/> does not engage or disengage freely	
foundation	<input type="checkbox"/> cracked, corroded, otherwise damaged	<input type="checkbox"/> does not provide adequate support	
comments:			
authorized signature: _____		date _____	

problem	cause	correction
handle turns hard or not at all	• parts dirty or corroded	clean or replace as necessary
	• drum shaft broken or seized.	inspect and replace as necessary
overheating	• operated too long without rest	allow to cool
	• load too heavy	lighten load
	• poor lubrication.	inspect and lubricate as necessary
unusual noises	high pitched squeak	• poor lubrication. inspect and relubricate as necessary
	grinding noise	• parts dirty or corroded clean or replace as necessary
	rattling noise	• loose bolts, setscrews or other fasteners. tighten all bolts and other fasteners

Model RW50 Cable Wind-Up Spool			
item	description	part number	qty.
1	FRAME	C3382	1
2	DRUM WELDMENT	C3384	1
3	DRUM SHAFT	B4247	1
4	HEX JAM NUT .500-13NC	A4328	1
5	FLAT NYLON WASHER .750	A8102	1
6	LOCKING HEX NUT REV .750-10NC	A8099	1
7	HANDLE	A8022	1
8	HANDLE SHAFT	A8096	1
9	CAPSCREW SOCBTNHD .312-18NC X .500 SST	A8100	2
10	SHOULDER SCREW .500 X .75	A8101	1
11	HEX JAM NUT .375-16NC	A3330	1
12	SPRING	B1145	1
13	RATCHET PAWL	B2477	1
14	TIE DOWN	A5922	1
15	HEX NUT .250-20NC SST	A3331	1
16	CARRIAGE BOLT .250-20NC X .75 SST	A2846	1
17	LABEL (TURN FOR TAKE UP)	A1923	1
18	LABEL (MOTOR CAPACITY)	A8103	1
19	LABEL (WARNING)	A1978	1
20	LABEL (KEEP HANDS AWAY)	A4512	1

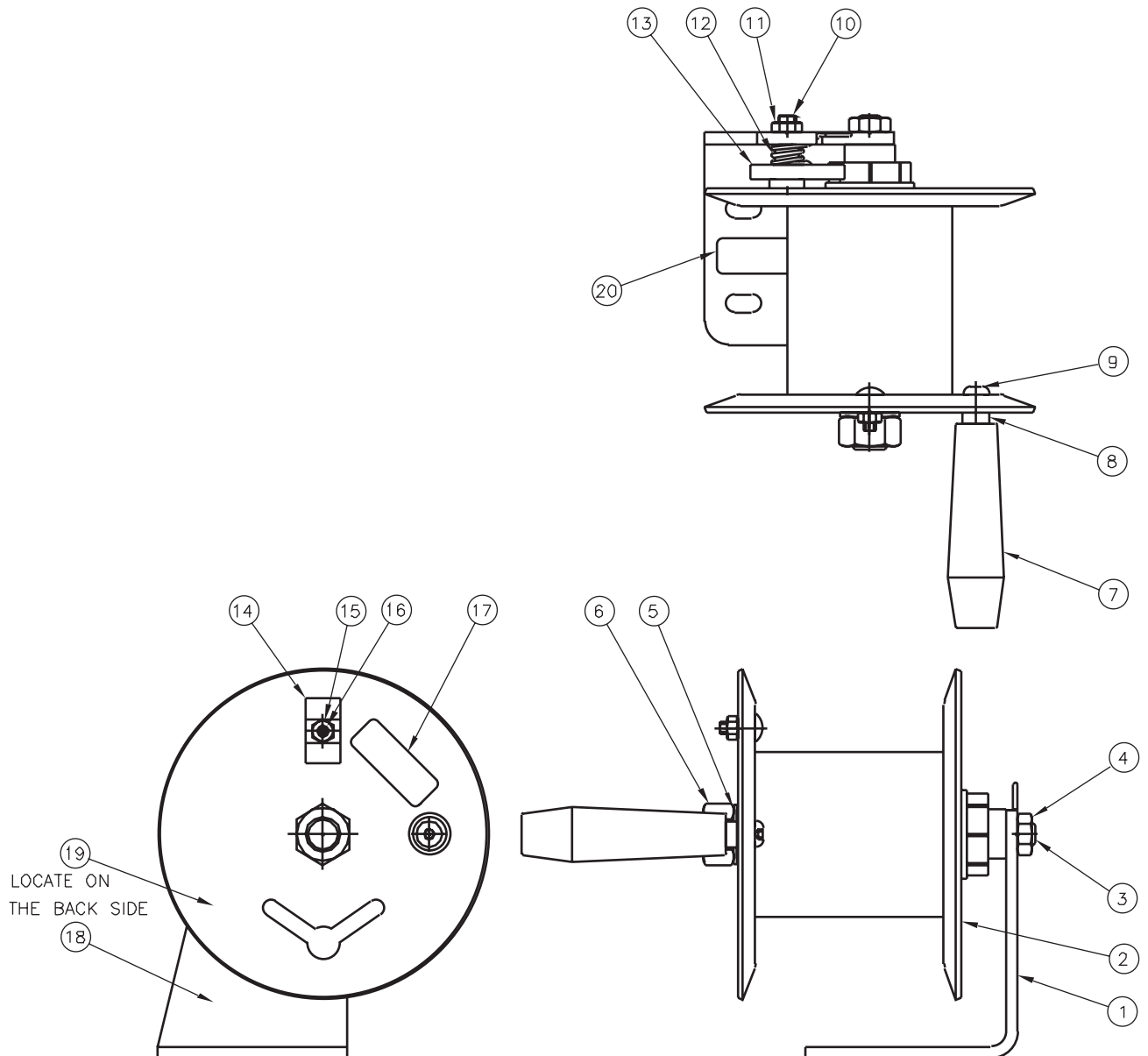



THERN

**Thern, Incorporated
5712 Industrial Park Road
Winona, MN 55987**

**PHN 507-454-2996
FAX 507-454-5282**

**EMAIL: info@thern.com
www.thern.com**