



Read this Owner's Manual thoroughly before operating the equipment. Keep it with the equipment at all times. Replacements are available from Thern, Inc., PO Box 347, Winona, MN 55987, 507-454-2996. www.thern.com

IMPORTANT: Please record product information on page 2. This information is required when calling the factory for service.



Owner's Manual

For
Model 548
Floor Crane

Two-Year Limited Warranty

Please record the following:

Date Purchased: _____

Crane Model No.: _____

Crane Serial No.: _____

This information is required when calling the factory for service.

Thern, Inc. warrants its products against defects in material or workmanship for two years from the date of purchase by the original using buyer, or if this date cannot be established, the date the product was sold by Thern, Inc. to the dealer. To make a claim under this warranty, contact the factory for an RGA number. The product must be returned, prepaid, directly to Thern, Inc., 5712 Industrial Park Road, Winona, Minnesota 55987. The following information must accompany the product: the RGA number, the date of purchase, the description of the claimed defect, and a complete explanation of the circumstances involved. If the product is found to be defective, it will be repaired or replaced free of charge, and Thern, Inc. will reimburse the shipping cost within the contiguous USA.

This warranty does not cover any damage due to accident, misuse, abuse, or negligence. Any alteration, repair or modification of the product outside the Thern, Inc. factory shall void this warranty. This warranty does not cover any costs for removal of our product, downtime, or any other incidental or consequential costs or damages resulting from the claimed defects. This warranty does not cover brake discs, wire rope or other wear components, as their life is subject to use conditions which vary between applications.

FACTORY AUTHORIZED REPAIR OR REPLACEMENT AS PROVIDED UNDER THIS WARRANTY IS THE EXCLUSIVE REMEDY TO THE CONSUMER. THERN, INC. SHALL NOT BE LIABLE FOR ANY INCIDENTAL OR CONSEQUENTIAL DAMAGES FOR BREACH OF ANY EXPRESS OR IMPLIED WARRANTY ON THIS PRODUCT. EXCEPT TO THE EXTENT PROHIBITED BY APPLICABLE LAW, ANY IMPLIED WARRANTY OF MERCHANTABILITY OR FITNESS FOR A PARTICULAR PURPOSE ON THIS PRODUCT IS LIMITED IN DURATION TO THE DURATION OF THIS WARRANTY.

Some states do not allow the exclusion or limitation of incidental or consequential damages, or allow limitations on how long an implied warranty lasts, so the above limitation or exclusion may not apply to you. This warranty gives you specific legal rights, and you may also have other rights which vary from state to state.

Note: Thern, Inc. reserves the right to change the design or discontinue the production of any product without prior notice.

About This Manual

The Occupational Safety and Health Act of 1970 states that it is the employer's responsibility to provide a workplace free of hazard. To this end, all equipment should be installed, operated, and maintained in compliance with applicable trade, industrial, federal, state, and local regulations. It is the equipment owner's responsibility to obtain copies of these regulations and to determine the suitability of the equipment to its intended use.

This Owner's Manual, and warning labels attached to the equipment, are to serve as guidelines for hazard-free installation, operation, and maintenance. They should not be understood to prepare you for every possible situation.

The information contained in this manual is applicable only to the Thern Model 548 Floor Crane. Do not use this manual as a source of information for any other equipment.

The following symbols are used for emphasis throughout this manual:

▲WARNING

Failure to follow 'WARNING!' instructions may result in equipment damage, property damage, and/or serious personal injury.

▲CAUTION

Failure to follow 'CAUTION!' instructions may result in equipment damage, property damage, and/or minor personal injury.

Important!

Failure to follow 'important!' instructions may result in poor performance of the equipment.

Suggestions for Safe Operation



⚠WARNING

DO the following:

Read and comply with the guidelines set forth in this Owner's Manual. Keep this manual, and all labels attached to the crane, readable and with the equipment at all times. Contact Thern, Inc. for replacements.

Check lubrication before use.

Use a sling or other approved lifting device.

Keep hands away from moving parts of the equipment.

Keep all unnecessary personnel away from crane while in operation.

DO NOT do the following:

Do not lift people, or things over people. Do not walk or work under a load or in the line of force of any load.

Do not exceed the load rating of the crane or any other component in the system. To do so could result in failure of the equipment.

Do not use more than one crane to move a load that exceeds the load rating of a single crane. A shift in load weight could overload the equipment.

Do not use damaged or malfunctioning equipment. To do so could result in failure of the equipment.

Do not modify the equipment in any way. To do so could cause equipment failure.

Do not divert your attention from the operation. Stay alert to the possibility of accidents, and try to prevent them from happening.

Do not jerk or swing the load. Avoid shock loads by starting and stopping the load smoothly. Shock loads overload the equipment and may cause damage.

Do not use the crane to drag or pull loads. This will create side pulls which could damage the equipment or cause the load to tip.

Do not leave a suspended load unattended. Place the load on the ground if it must be left unattended.

1.1 Assembling the Crane

Important!

- Inspect the crane during assembly according to the Instructions for Periodic Inspection. This will give you a record of the condition of the crane with which to compare future inspections.
- Save all boxes and crates that the crane was shipped in, use them again if you need to repack the crane.
- Contact the factory immediately if any parts are missing or damaged.
- Do not overtighten fasteners, this may strip threads or cause damage to other parts.

Figure 1 – Cotter Pins

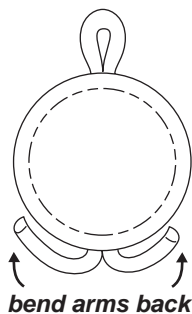

⚠ CAUTION

When the boom is released from its folded position, it moves rapidly and with force. Keep the area in front of the boom (between the crane legs) clear of any obstruction when releasing the boom.

- 1.1.1 OPEN CARTON and **thoroughly check contents** against parts list.
- 1.1.2 STUDY PARTS DRAWINGS to understand how the crane is assembled. See page 15.
- 1.1.3 ITEMS 1, 9, 22 and 23 have been factory assembled using items 4, 5, 7, 8, 10, 11, 12, 13, 14, 15, 18, 24, 25 and 26.
- 1.1.4 LUBRICATE PINS and other components prior to assembly. See Section 3.2 Lubricating the Crane.
- 1.1.5 ASSEMBLE THE CRANE
 - a ASSEMBLE THE SWIVEL CASTERS (item 2) to the crane with 5/16" x 3/4" cap screws (item 3), 5/16" lock washers (item 5) and 5/16" hex nuts (item 4).
 - b ASSEMBLE THE WHEELS (item 6) at the ends of the legs (item 20 and 21) using the axle bolts (item 19).
 - c ASSEMBLE THE HANDLE (item 28) onto the frame weldment (item 1) with 5/16" x 1" cap screw (item 26), 5/16" lock washer (item 5) and 5/16" hex nut (item 4).
 - d ASSEMBLE HANDLE GRIPS (item 27) onto handle.
 - e SLIDE THE LEGS into the frame of the crane as shown on the drawing. Be sure they are assembled properly so the wheels are parallel with each other. Secure the legs with the leg pin assembly (item 7), which is attached to the frame with cables.
 - f THE CRANE IS DESIGNED to fold up into a compact package for storage and transport. It is folded when shipped from the factory.
 - To release the boom to its working position, turn the release valve counterclockwise until the boom pops out to its working position.
 - Turn the release valve clockwise until it is tight and use the jack handle to operate jack to move the boom to a horizontal position.
 - g PLACE JACK HANDLE in its holster.
 - h ASSEMBLE THE SWIVEL HOOK weldment (item 16) to the boom extension (item 23) with the swivel pin (item 17). Secure the swivel pin with two 5/32" x 1" cotter pins (item 18).
- 1.1.6 CHECK CRANE over to see that all bolts are tight and all cotter pins bent to secure. See figure 1.

2.1 General Theory of Operation

Important!

- It is your responsibility to detect and account for different factors affecting the condition and performance of the equipment.

⚠ CAUTION

Avoid shock loads created by quickly opening and closing the release valve as a load is being lowered. Shock loads may overload the hydraulic circuit and cause damage to the jack.

- 2.1.1 **THE FORCE REQUIRED** to move the load must not exceed the load rating of the crane. Consider the total force required to move the load, not the weight of the load.
- 2.1.2 **THIS EQUIPMENT CAN** develop forces that will exceed the load rating. It is the responsibility of the equipment user to limit the size of the load. Inspect the equipment regularly for damage according to the instructions contained in this manual.
- 2.1.3 **PERFORMANCE RATINGS** of the equipment are affected by the position of the boom.
- a **LOAD RATING** represents the maximum load that can be placed on new equipment. Load ratings are assigned values for specific boom positions. **The load rating decreases as you increase boom length.**
 - b **LIFT HEIGHT AND REACH** vary with the position of the boom.
- 2.1.4 **DUTY RATINGS** refer to the type of use the equipment is subject to. Consider the following when determining duty rating.
- a **ENVIRONMENT:** harsh environments include hot, cold, dirty, wet, corrosive, or explosive surroundings. **Protect the equipment from harsh environments when possible.**
 - b **MAINTENANCE:** poor maintenance, meaning poor cleaning, lubrication, or inspection, leads to poor operation and possible damage of the equipment. **Minimize poor maintenance by carefully following the instructions contained in this manual.**
 - c **LOADING:** severe loading includes shock loading and moving loads that exceed the load rating of the equipment. **Avoid shock loads, and do not exceed the load rating of the equipment.**
 - d **FREQUENCY OF OPERATION:** frequent or lengthy operations increase wear and shorten the life span of bearings, sheaves, and other components. **Increase maintenance of the equipment if used in frequent operations.**
 - e **WHEN NOT IN USE,** always leave the hydraulic jack ram all the way down.

CONTACT THE FACTORY FOR MORE INFORMATION.

2.2 Preparing for Operation

Important!

- When determining whether the load will exceed the load rating, consider the total force required to move the load.

⚠ WARNING

Do not use the crane in an area defined as hazardous by the National Electric Code, unless use in such an area has been thoroughly approved.

Do not use the crane near corrosive chemicals, flammable materials, explosives, or other elements that may damage the crane or injure the operator. Adequately protect the crane and the operator from such elements.

Use the crane on a rigid and level surface that will support the crane and its load under all load conditions, including shock loading.

2.2.1 **CONSIDER THE OPERATION.** Do not begin until you are sure you can perform the entire operation without hazard.

2.2.2 **INSPECT ALL COMPONENTS** of the system.

a **INSPECT THE CRANE** and other equipment according to the Instructions for Frequent Inspection.

b **OPERATORS** must be in good health, alert, thoroughly trained in operating the equipment, and properly clothed (hard hat, safety shoes and safety glasses, no loose clothing).

c **THE LOAD** must be clear of other objects and free to move. Make sure the load will not tip, spin, roll away, or in any way move uncontrollably.

2.2.3 **KNOW YOUR LOAD** and make sure you do not exceed the load rating of the crane or any other equipment in the system.

2.2.4 **POSITION THE CRANE AND BOOM** so the load hook is centered over the load. **Avoid side pulls which could damage the crane or cause the load to tip.** See figure 2.

2.2.5 **ADJUSTING THE BOOM.** See figure 2.

a **REMOVE ANY LOAD** from the crane and disengage hook from load.

b **LOCATE BOOM** in horizontal position to make adjustment easier.

c **REMOVE BOOM EXTENSION PIN** and adjust boom extension to desired position, then re-insert pin. The boom extension pin must be removed only when adjustments are being made. It must always be re-installed immediately.

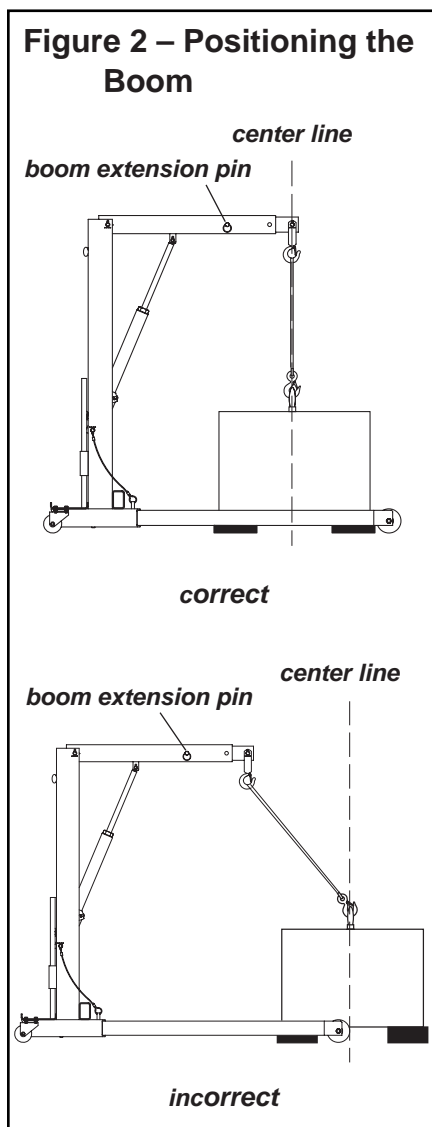

2.3 Attaching the Load

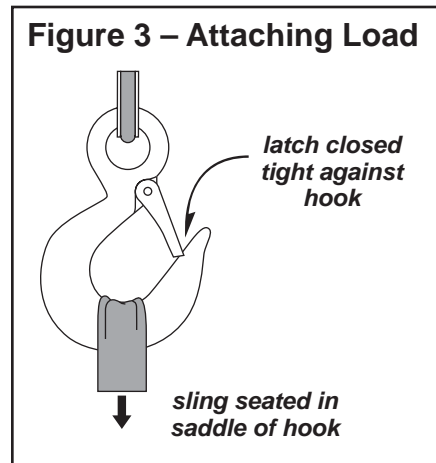

- 2.3.1 CLEAR OBJECTS from the path you will travel, so you can move freely and observe the load at all times during the operation.
- 2.3.2 ATTACH THE LOAD using a nylon sling, or other approved lifting device. Follow the recommendations of the sling manufacturer.
 - a SEAT THE SLING in the saddle of the hook with the hook latch completely closed. See figure 3.
 - b CENTER THE LOAD on the hook so it will remain balanced and not tip or rotate to one side.

2.4 Moving the Load

Important!

- Obey a stop signal from anyone.
- Appoint a supervisor if more than one person is involved in the operation. This will reduce confusion and increase safety.
- When lifting or moving the load, use a tag line to keep the load from swinging or twisting, while keeping yourself away from the load.

- 2.4.1 LIFT THE LOAD slowly and smoothly. Make sure the load is balanced and securely attached before lifting. See figure 4.
- 2.4.2 OPERATE THE HYDRAULIC JACK to raise or lower the load.
 - a RAISE THE LOAD by smoothly pumping the hydraulic jack with the handle. With new equipment, a whining noise may occur when pumping.
 - b LOWER THE LOAD by slowly turning the release valve counterclockwise. **Too many full turns will unscrew the valve and release oil.**
 - c Close the valve by tightening it clockwise.
- 2.4.3 PULL THE CRANE BACKWARD to move the load, with the load close to the floor and tied to the mast and legs to prevent swinging. See figure 4.
- 2.4.4 MOVE THE LOAD slowly and smoothly, especially when making turns.
- 2.4.5 MOVE THE CRANE BY HAND ONLY. **Do not use powered devices to push or pull the crane.**

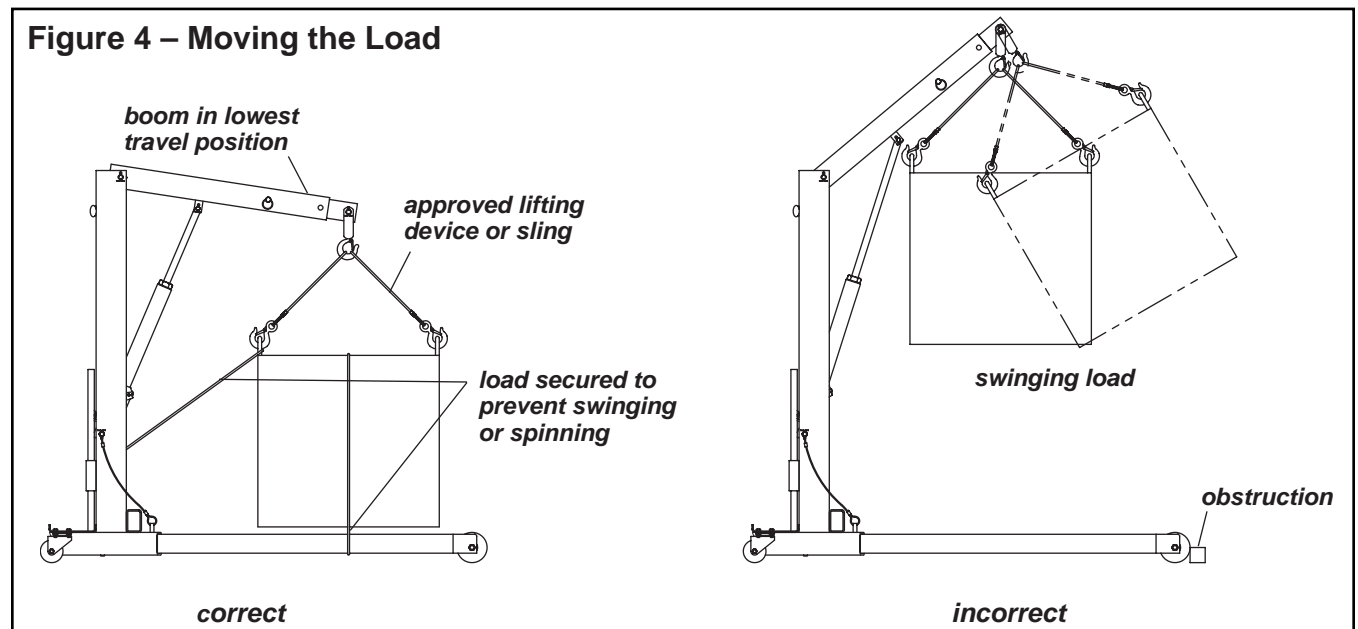

3.1 Cleaning the Crane

Important!

Increase the frequency of maintenance procedures if the crane is:

- Operated for long periods.
- Used to lift heavy loads.
- Operated in wet, dirty, hot, or cold surroundings.

Clean the crane to remove dirt and help prevent rust and corrosion.

- 3.1.1 CLEAN THE CRANE every six months or whenever it is dirty.
- a WIPE ALL EQUIPMENT to remove dirt and grease.
 - b LEAVE A LIGHT FILM of oil on all surfaces to protect against rust and corrosion.
 - c WIPE OFF excessive amounts of oil to avoid the accumulation of dirt.
- 3.1.2 REMOVE UNNECESSARY OBJECTS from the area surrounding the crane.

3.2 Lubricating the Crane

Important!

- Make sure lubricant has a temperature rating appropriate for the ambient temperatures of the operation.

Lubricate the crane properly to help protect it from wear and rust. Read the following instructions carefully.

Partial disassembly may be required to lubricate the crane properly to help protect from wear and corrosion.

- 3.2.1 LUBRICATE THE WHEELS at least every 6 months. Use a grease brush to apply a light film of NLGI #2 grease to the roller bearings on the rear caster wheels. Apply 2 to 3 drops of 150 grade gear oil to the shafts on the front wheels, rotate the wheels to allow oil to penetrate, and wipe off excess oil to avoid accumulation of dirt.
- 3.2.2 LUBRICATE ALL PINS at least every 6 months. Use a grease brush to apply a light film of NLGI #2 grease to all pins.
- 3.2.3 LUBRICATE THE SWIVEL HOOK at least every 6 months. Apply 2 to 3 drops of 150 grade gear oil, rotate the hook to allow oil to penetrate, and wipe off excess oil to avoid accumulation of dirt.
- 3.2.4 CHECK OIL LEVEL IN THE HYDRAULIC JACK by removing it from the crane and setting it upright on a level surface. Turn the release valve counterclockwise, no more than 3 turns. Too many full turns will unscrew the valve and release oil. Push the ram down and remove the filler plug. Fill with ISO 15 hydraulic oil, until oil reaches the level of the fill hole. **Do not overfill, this may cause serious damage.**
- 3.2.5 LUBRICATE THE JACK pivot pins and other moving parts after 10 cycles.
- 3.2.6 LUBRICATE EQUIPMENT by following the manufacturers recommendations.

3.3 Inspecting the Equipment

Important!

- Start an inspection program as soon as you put the crane into use.
- Appoint a qualified person to be responsible for regularly inspecting the equipment.
- Keep written records of inspection. This allows comparison with comments from previous inspections so you can see changes in condition or performance.

Perform frequent inspections:

- Before each operation.
- Every 3 hours during operation.
- Whenever you notice signs of damage or poor operation.

⚠WARNING

Do not use damaged or malfunctioning equipment. Place an “OUT OF ORDER” sign on the crane. Do not use the crane until the sign is removed by a qualified maintenance person who has completely corrected the problem.

Inspect the crane to detect signs of damage or poor operation before they become hazardous.

3.3.1 **CONSULT APPLICABLE CODES AND REGULATIONS** for specific rules on inspecting the crane and other equipment.

3.3.2 **Instructions for Frequent Inspection**

- a **VISUALLY INSPECT** the entire crane and all other equipment involved in the operation.
 - Check all equipment for cracks, dents, bending, rust, wear, corrosion and other damage.
 - Make sure the entire crane is properly lubricated.
 - Make sure all fasteners are tight and secure.
 - Make sure the surface under the crane is in good condition, and capable of supporting the crane and its load under all load conditions.
- b **TEST CRANE PERFORMANCE** by operating the crane with a load not exceeding the load rating.
 - Listen for unusual noises, and look for signs of damage as you operate the crane.
 - Make sure the hydraulic jack raises and lowers the load smoothly, without hesitation or strain.
 - Make sure the floor crane rolls smoothly and freely, without swerving or binding.
 - To remove air from the jack insert handle onto release valve and turn counterclockwise no more than 3 turns. Place handle in handle socket and pump handle 6 to 8 strokes. Repeat as required.

Completely correct all problems before continuing. Use the Troubleshooting Chart to help determine the cause of certain problems. See table 2.

Perform periodic inspections:

- Every 6 months.
- Whenever you return the crane to service from storage.
- Whenever you notice damage or poor operation in a frequent inspection.
- Whenever you have, or think you may have, overloaded or shock loaded the crane.

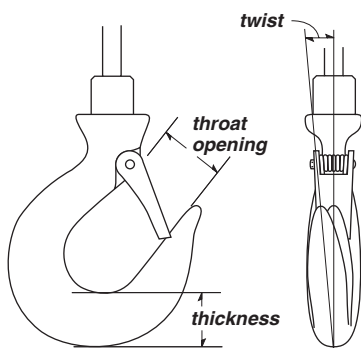
Figure 5 – Load Hook Inspection

The wire rope assembly must be replaced if the throat opening is 15% wider than nominal, if the thickness is 10% less than nominal, or if the hook is twisted 10° or more.

3.3.4 Instructions for Periodic Inspection

a **VISUALLY INSPECT THE CRANE** and all other equipment. Disassemble the crane as necessary to inspect individual components.

- Check the finish for wear, flaking, or other damage.
- Check all equipment for cracks, dents, bending, rust, wear, corrosion and other damage. If the equipment was overloaded, or if you notice cracks and other signs of overloading and damage promptly remove equipment from use and have it repaired or replaced. **DO NOT CONTINUE TO USE DAMAGED OR OVERLOADED EQUIPMENT.**
- Check all fasteners for stripped threads, wear, bending, and other damage.
- Measure the throat opening, thickness, and twist of the hook. Replace the hook if it shows signs of damage. See figure 5.
- Make sure hook latch opens without binding and closes when released.
- Check the hydraulic jack for leaks, bending, wear, and other damage.
- Drain a small amount of oil from the hydraulic jack and check for contamination. Fill the jack with the proper oil. See Section 3.2 Lubricating the Crane.
- Make sure the entire crane is properly lubricated.
- Make sure all labels and plates are readable, firmly attached, free of damage and clean. Replacements are available from the factory.

b **TEST CRANE PERFORMANCE** by operating the crane with a test load equal not exceeding the load rating.

- Listen for unusual noises and look for signs of damage as you operate the crane.
- Make sure the hydraulic jack raises and lowers the load smoothly, without hesitation or strain.
- Make sure the crane rolls smoothly and freely, without swerving or binding.

Completely correct all problems before continuing. Use the Troubleshooting Chart to help determine the cause of certain problems. See table 2.

3.4 Repairing the Crane

Important!

- It is your responsibility to determine when to replace parts. When considering whether to continue using a part or to replace it, remember that replacing it is the best way to avoid further equipment damage.
- Appoint a qualified person to be responsible for all repairs to the equipment.

- 3.4.1 GET FACTORY AUTHORIZATION for all repairs. Unauthorized repairs will void the warranty, and may lead to damage or failure of the crane.
- 3.4.2 REPLACE DAMAGED OR POORLY OPERATING PARTS with Thern repair parts.
- 3.4.3 REFINISH AREAS where the paint is worn or flaking. A good finish helps to protect against corrosion and weather damage.
- a REMOVE THE FINISH from damaged areas, down to the bare metal.
 - b CLEAN THE AREA thoroughly.
 - c REPAINT with a high quality primer and finishing coat.
- 3.4.4 TO ORDER REPAIR PARTS, contact your local dealer. Include the following information when ordering:
- model number
 - serial number (or code number)
 - part number
 - date purchased, and from whom
 - description of what happened, or what is wrong
 - your name and return address
- 3.4.5 THE HYDRAULIC JACK B4539 is a modified Enerpac EBJL1.5GC.
- a If you would like to purchase a new jack for the crane, please contact Thern, Inc.
 - b If you would like to order repair parts, please contact Enerpac Technical Services at 1-800-558-0530. All Enerpac service components are sold through their authorized service centers. You may choose to use their distributor/service center locator found on the Enerpac website: http://www.enerpac.com/main_navigation/distributors/home.htm

Figure 6 – Collapsing the Crane



Important!

- Keep a record of what you ship, and when you send it.

4.1 Collapsing the Crane

- 4.1.1 ADJUST THE BOOM EXTENSION to its shortest length.
- 4.1.2 LOWER THE BOOM, leaving the release valve untightened.
- 4.1.3 PUSH THE BOOM tight against the stop which contains the handle spring. At the same time, tighten the release valve. Then pump on the jack handle until the unit locks in a collapsed position. **Do not force the jack handle. Forcing the jack handle with the crane collapsed will quickly overload the pump resulting in failure.**
- 4.1.4 REMOVE THE LEG PINS, remove the legs and slide them into the mast tubes. Study parts drawing, see page 15.

4.2 Transporting the Crane

- 4.2.1 PARTIALLY DISASSEMBLE THE CRANE into parts that can be easily transported.
- 4.2.2 PACK THE CRANE for transport, using the original packaging materials, if appropriate.
- 4.2.3 REASSEMBLE THE CRANE at its new location following the instructions under Section 1.1 Assembling the Crane.
- 4.2.4 INSPECT THE CRANE according to Section 3.3 Inspecting the Equipment under Instructions for Frequent Inspection before installing it for operation.

4.3 Storing the Crane

- 4.3.1 DISASSEMBLE THE CRANE and store all parts in a cool clean place away from corrosive chemicals and moisture.
- 4.3.2 LUBRICATE THE CRANE according to Section 3.2 Lubricating the Crane.
- 4.3.3 SEAL THE CRANE in plastic with a desiccant to help protect it from rust, corrosion, and other damage.
- 4.3.4 REASSEMBLE THE CRANE at its new location following the instructions under Section 1.1 Assembling the Crane.
- 4.2.5 INSPECT THE CRANE according to Section 3.3 Inspecting the Equipment under Instructions for Periodic Inspection before installing it for operation.

Model 548 Floor Crane			
item	description	part number	qty
1	FRAME	D1019	1
2	SWIVEL CASTER 3 X 1.25	A2798	2
3	CAPSCREW HEXHD .312-18NC X .750	A3032	8
4	HEX NUT .312-18NC	A3250	11
5	WASHER HELSPRLK .312 X .586 X .078	A2925	11
6	WHEEL 4 X 1.5	A2799	2
7	LEG PIN ASSEMBLY	A1369	2
8	HEADLESS PIN .625 X 8.618	A1327	2
9	HYDRAULIC JACK	B4539	1
10	JACK BASE	C1066	1
11	CAPSCREW HEXHD .250-20NC X 1.000	A3228	4
12	HEX NUT .250-20NC	A3200	4
13	HELSPRLK WASHER .250 X .489 X .062	A3075	4
14	CLEVIS PIN .500 X 1.516	A1368	1
15	QUICK RELEASE PIN .625 X 2.250	A1366	1
16	SWIVEL WELDMENT	C1070	1
17	HEADLESS PIN .625 X 2.282	A1352	1
18	COTTER PIN .156 X 1.000	A3059	5
19	AXLE BOLT .500 X 2.750	A2806	2
20	RIGHT LEG	C1065	1
21	LEFT LEG	C1064	1
22	BOOM	C1067	1
23	BOOM EXTENSION	B1126	1
24	HANDLE SPRING 1.095OD X .142WD	A1332	1
25	HANDLE SPRING WASHER	A1385	1
26	CAPSCREW HEXHD .312-18NC X 1.000	A3028	3
27	BLACK HANDLE GRIP	A1043	2
28	HANDLE	A1435	1
29	LABEL IMPORTANT ALWAYS INSERT THIS PIN	A2188	4
30	THERN LOGO	A2178	1
31	LABEL MODEL/CAPACITY	B1144	2
32	LABEL WARNING READ BEFORE USING	A1302	1
33	LABEL NAMEPLATE SST	A1976	1
34	LABEL STOP LIFT AT THIS POINT	A1363	1

Model 548 Performance Characteristics ¹			
	load rating	max. hook reach (at B)	max. hook height (at C)
boom position 1	1000 lb	31.0 in	65.0 in
boom position 2	800 lb	38.0 in	69.5 in
boom position 3	680 lb	45.0 in	74.0 in
boom position 4	590 lb	52.0 in	78.5 in

Dimensions are for reference only and subject to change without notice.

¹ Performance Characteristics are for standard products referred to in this manual. Non-standard products may vary from the original design. Contact Thern, Inc. for this information.



THERN

**Thern, Incorporated
5712 Industrial Park Road
Winona, MN 55987**

**PHN 507-454-2996
FAX 507-454-5282**

**EMAIL: info@thern.com
www.thern.com**