

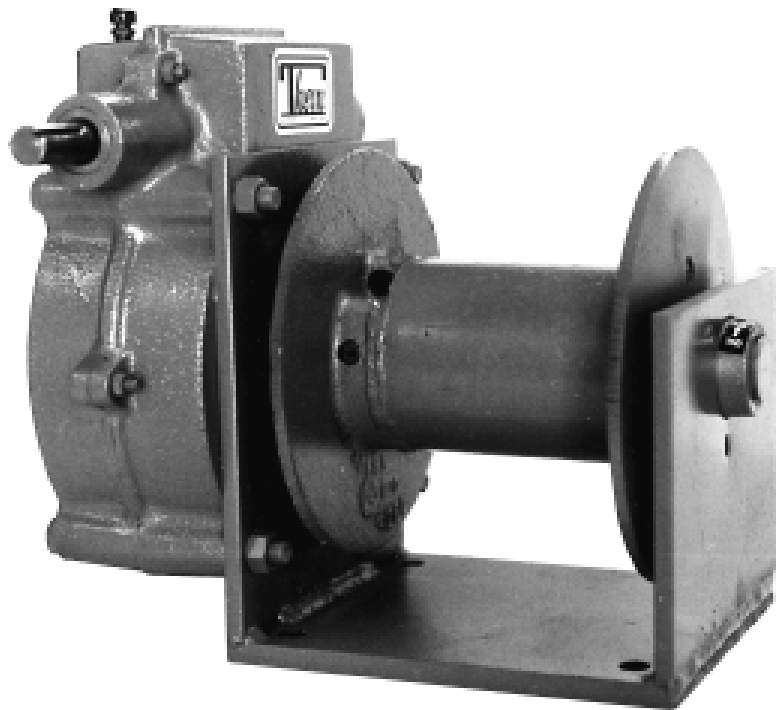

Read this Owner's Manual thoroughly before operating the winch. This manual tells you how to install, operate, and maintain the winch. Keep it with the winch at all times. Replacements are available from Thern, Inc., PO Box 347, Winona, MN 55987, 507-454-2996.



Owner's Manual

For Worm Gear Power Winches
Series 474 and 484

Two-Year Limited Warranty

Thern, Inc. warrants its products against defects in material or workmanship for two years from the date of purchase by the original using buyer, or if this date cannot be established, the date the product was sold by Thern, Inc. to the dealer. To make a claim under this warranty, the product must be returned, prepaid, directly to Thern, Inc., 5712 Industrial Park Road, Winona, Minnesota 55987. The following information must accompany the product: the date of purchase, the description of the claimed defect, and a complete explanation of the circumstances involved. If the product is found to be defective, it will be repaired or replaced free of charge, and Thern, Inc. will reimburse the shipping cost.

This warranty does not cover any damage due to accident, misuse, abuse, or negligence. Any alteration, repair or modification of the product outside the Thern, Inc. factory shall void this warranty. This warranty does not cover any costs for removal of our product, downtime, or any other incidental or consequential costs or damages resulting from the claimed defects. This warranty does not cover brake discs, as these are wear components and their life is subject to use conditions which vary between applications.

FACTORY AUTHORIZED REPAIR OR REPLACEMENT AS PROVIDED UNDER THIS WARRANTY IS THE EXCLUSIVE REMEDY TO THE CONSUMER. THERN, INC. SHALL NOT BE LIABLE FOR ANY INCIDENTAL OR CONSEQUENTIAL DAMAGES FOR BREACH OF ANY EXPRESS OR IMPLIED WARRANTY ON THIS PRODUCT. EXCEPT TO THE EXTENT PROHIBITED BY APPLICABLE LAW, ANY IMPLIED WARRANTY OF MERCHANTABILITY OR FITNESS FOR A PARTICULAR PURPOSE ON THIS PRODUCT IS LIMITED IN DURATION TO THE DURATION OF THIS WARRANTY.

Some states do not allow the exclusion or limitation of incidental or consequential damages, or allow limitations on how long an implied warranty lasts, so the above limitation or exclusion may not apply to you. This warranty gives you specific legal rights, and you may also have other rights which vary from state to state.

Note: Thern, Inc. reserves the right to change the design or discontinue the production of any product without prior notice.

About This Manual

The Occupational Safety and Health Act of 1970 states that it is the employer's responsibility to provide a work-place free of hazard. To this end, all equipment should be installed, operated, and maintained in compliance with applicable trade, industrial, federal, state, and local regulations. It is the equipment owner's responsibility to obtain copies of these regulations and to determine the suitability of the equipment to its intended use.

This Owner's Manual, and warning labels attached to the equipment, are to serve as guidelines for hazard-free installation, operation, and maintenance. They should not be understood to prepare you for every possible situation.

The information contained in this manual is applicable only to the Thern 474 and 484 Series Worm Gear Power Winches. Do not use this manual as a source of information for any other equipment.

The following symbols are used for emphasis throughout this manual:

▲WARNING

Failure to follow 'WARNING!' instructions may result in equipment damage, property damage, and/or serious personal injury.

▲CAUTION

Failure to follow 'CAUTION!' instructions may result in equipment damage, property damage, and/or minor personal injury.

Important!

Failure to follow 'important!' instructions may result in poor performance of the equipment.

Suggestions for Safe Operation

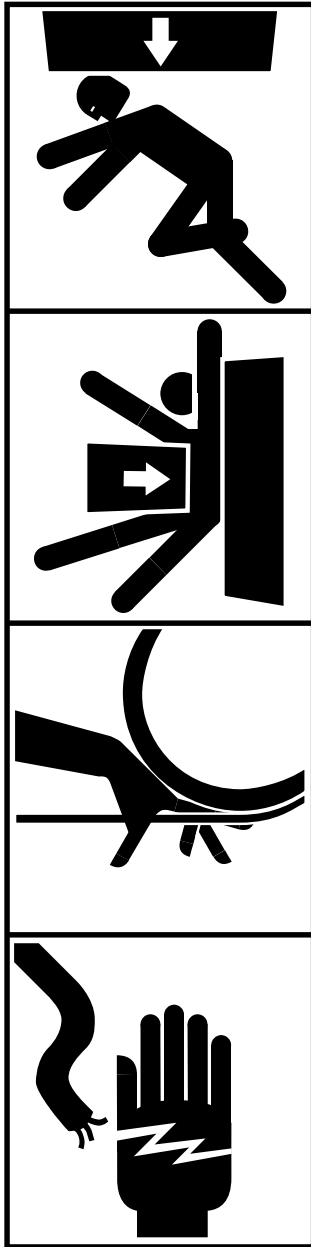

⚠️WARNING

DO the following:

Read and comply with the guidelines set forth in this Owner's Manual. Keep this manual, and all labels attached to the winch, readable and with the equipment at all times. Contact Thern, Inc. for replacements.

Check lubrication before use.

Install the wire rope securely to the winch drum.

Keep at least 4 wraps of wire rope wound on the drum at all times, to serve as anchor wraps. Failure to do so could cause the load to fall.

Keep hands away from the drum, wire rope, and other moving parts of the equipment.

Equip the winch with a load brake if it is used to lift loads, or drag loads on an incline.

Disconnect electric power before servicing the equipment.

DO NOT do the following:

Do not lift people, or things over people. Do not walk or work under a load or in the line of force of any load.

Do not exceed the load rating of the winch or any other component in the system.

Do not use more than one winch to move a load that exceeds the load rating of a single winch. A shift in load weight could overload the equipment.

Do not use damaged or malfunctioning equipment. To do so could result in failure of the equipment.

Do not modify the equipment in any way. To do so could cause equipment failure.

Do not wrap the wire rope around the load. This damages the wire rope and could cause the load to fall. Use a sling or other approved lifting device.

Do not operate the winch with guards removed or improperly installed.

Do not divert your attention from the operation. Stay alert to the possibility of accidents, and try to prevent them from happening.

Do not jerk or swing the load. Avoid shock loads by starting and stopping the load smoothly. Shock loads overload the equipment and may cause damage.

Do not adjust the brake with the load suspended.

Table of Contents

Installation		5 – 8
1.1	Installing the Winch	5
1.2	Installing a Handle	6
1.3	Installing Power	7
1.4	Installing the Wire Rope	8
Operation		9 – 12
2.1	General Theory of Operation	9
2.2	Suggestions for Safe Operation	10
2.3	Breaking-In the Winch	11
2.4	Preparing for Operation	11
2.5	Attaching the Load	11
2.6	Moving the Load	12
Maintenance		13 – 22
3.1	Cleaning the Winch	13
3.2	Adjusting the Electric Brake	13
3.3	Lubricating the Winch	14
3.4	Inspecting the Equipment	15
3.5	Disassembling the Winch	20
3.6	Reassembling the Winch	21
3.7	Repairing the Winch	22
Reference		23 – 31
4.1	Transporting the Winch	23
4.2	Storing the Winch	23
	repair parts	24 – 31

1.1 Installing the Winch

Important!

- Inspect the winch immediately following installation according to the Instructions for Periodic Inspection. This will give you a record of the condition of the winch with which to compare future inspections.
- A licensed professional should inspect or design the foundation to insure that it will provide adequate support.
- Locate the winch so it will be visible during the entire operation.
- When moving and positioning the winch, lift underneath the winch frame, or lift with a sling wrapped around the drum.
- Keep a type ABC fire extinguisher near the operation area.

⚠WARNING

Do not install the winch in an area defined as hazardous by the National Electric Code, unless installation in such an area has been thoroughly approved.

Do not install the winch near corrosive chemicals, flammable materials, explosives, or other elements that may damage the winch or injure the operator. Adequately protect the winch and the operator from such elements.

Position the winch so the operator can stand clear of the load, and out of the path of a broken wire rope that could snap back and cause injury.

Attach the winch to a rigid and level foundation that will support the winch and its load under all load conditions, including shock loading.

- 1.1.1 CONSULT APPLICABLE CODES AND REGULATIONS for specific rules on installing the equipment.
- 1.1.2 LOCATE THE WINCH in a place with the following characteristics.
 - a AREA CLEAR of traffic and obstacles that could interfere with operation. Make sure the winch is accessible for maintenance and operation.
 - b ADEQUATE TEMPERATURE, the winch is rated for operation in ambient temperatures ranging from 15° to 125° F.
- 1.1.3 POSITION THE WINCH HORIZONTALLY to insure proper lubrication. **Do not install the winch vertically or upside-down, unless it has been factory modified for this type of installation.**
- 1.1.4 MAINTAIN A FLEET ANGLE between 1/2 and 1-1/2 degrees. The proper fleet angle minimizes wire rope damage by helping the wire rope wind uniformly onto the drum. See figure 1.
- 1.1.5 FASTEN THE WINCH SECURELY to the foundation.

CONTACT A QUALIFIED PROFESSIONAL FOR MOUNTING INSTRUCTIONS.

Important!

- Use a sheave or roller guide to direct the wire rope to the drum whenever possible.
- Install sheaves, tracks and other equipment so they will remain fixed under all load conditions. Follow the recommendations of the equipment manufacturer.
- Use sheaves of proper diameter to minimize wear on the wire rope. Follow the recommendations of the sheave manufacturer.

Figure 1 – Maintaining the Fleet Angle

- When wire rope travels over a sheave or through a roller guide – maintain fleet angle by locating the sheave or guide an appropriate distance from the drum, shown as distance "A".

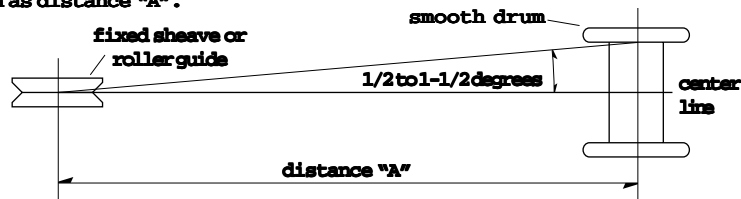

- When wire rope travels directly to the load – maintain fleet angle by controlling side-to-side movement of the load with tracks or guide rails. Allowing the load to move too far to one side causes stress on the drum flange which may cause damage.

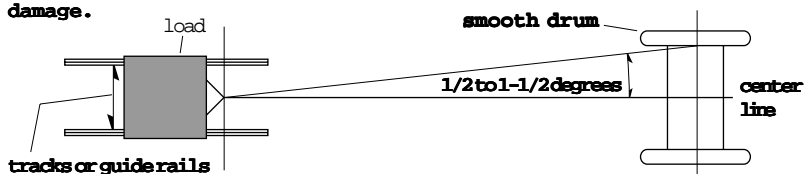

1.2 Installing a Handle

Important!

- Handles and load brakes are available from Thern. We recommend purchasing a complete handle assembly from Thern whenever possible.

The winch does not include a handle. It is the responsibility of the owner to select and install a handle for operating the winch. The following guidelines are for reference only and may not apply to your situation.

- 1.2.1 SELECT A HANDLE with the following guidelines in mind.
 - a HANDLE LENGTH should be adjustable to suit different operations.
 - b HANDLE LENGTH must not exceed 9 inches for the 474, and 12 inches for the 484.
 - c A HANDLE SOCKET or other device should be used so you can remove the handle when the winch is not in use, to help avoid unauthorized use.
 - d EQUIP THE WINCH with a load brake if it is used to lift loads or drag loads on an incline. Load brakes are available from Thern.
- 1.2.2 FASTEN THE HANDLE to the drive shaft.
- 1.2.3 ADJUST HANDLE LENGTH to suit the operation, and tighten the handle in place. See figure 2.
 - a SHORTEN HANDLE LENGTH for light loads or fast operation.
 - b INCREASE HANDLE LENGTH for heavy loads or slow operation.

Figure 2 – Handle Adjustment

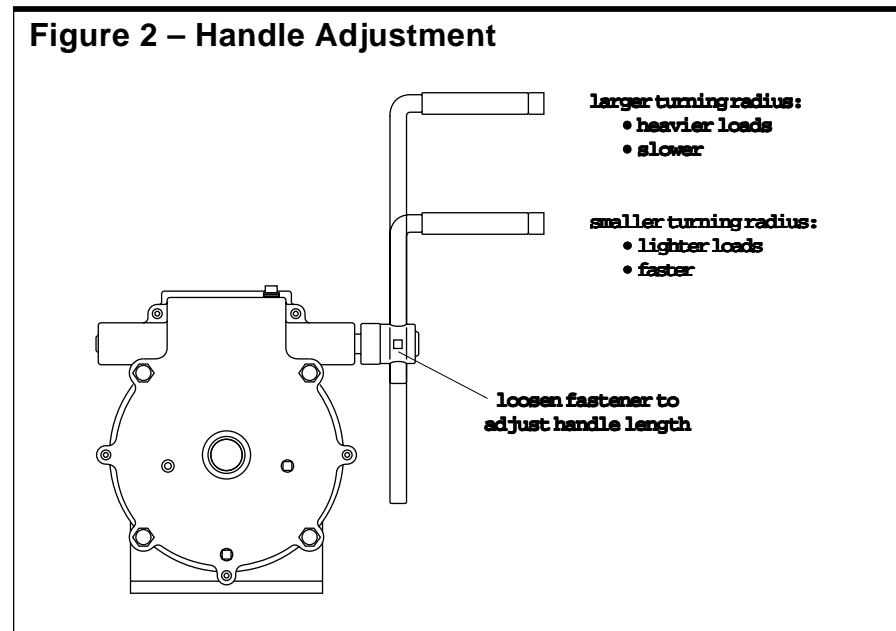

1.3 Connecting Power

Important!

- Motors and controls are available from Thern. We recommend purchasing a complete power winch system from Thern whenever possible.
- Use motors, controls, and other equipment with the correct rating to insure adequate performance.
- Always disconnect power when the winch is not in use.

⚠WARNING

Install proper branch circuits, disconnect devices, protection, and grounding as required by article 430 of the National Electric Code.

All electrical work must be performed by a licensed electrician. Failure to do so could result in electric shock or poor winch operation.

All control devices must be momentary contact type. Install all control devices so the winch motor will stop when the operator releases the device.

Locate control devices so the operator will be able to view the load through the entire operation.

Locate control devices so the operator will be clear of the load, the wire rope, and the path of a broken wire rope that could snap back and cause injury.

It is the responsibility of the owner to select and install a motor, drive train, and equipment for controlling the winch. The following guidelines are supplied as a reference for the installer, and may not apply to your situation.

- 1.3.1 CONSULT APPLICABLE CODES AND REGULATIONS for specific rules on installation of motors, drive trains, and controls.
- 1.3.2 SELECT MOTOR, drive train, and controls with the following in mind.
- MAXIMUM HORSEPOWER rating of the motor must not exceed 1 hp for the 474, and 2 hp for the 484.
 - MAXIMUM INPUT SPEED at winch drive shaft must not exceed 600 rpm.
- 1.3.3 INSTALL MOTOR, drive train, and controls with the following in mind.
- INSTALL A CIRCUIT BREAKER, relief valve, or other limiting device in the power supply circuit to interrupt power in case of overload.
 - INSTALL A DISCONNECT DEVICE in the power supply circuit. This should be a switch or valve you can lock in the off position to prevent unauthorized use of the winch.
 - EQUIP THE WINCH with a load brake if it is used to lift loads or drag loads on an incline.
 - CHECK THE RATING of the motor and make sure it agrees with the rating of the power supply.
 - EQUIP THE WINCH with guards that totally enclose the drive train, to help prevent injuries.
- 1.3.4 TEST CONNECTIONS by operating the winch.
- ROTATION OF THE DRUM must agree with the labels on the control device, either UP and DOWN, or FORWARD and REVERSE.
 - DETERMINE THAT THE LOAD BRAKE releases when the motor is ON, and engages when the motor is OFF.

CONTACT THE FACTORY OR A QUALIFIED PROFESSIONAL FOR HELP.

1.4 Installing the Wire Rope

Important!

- Use wire rope and other rigging equipment rated for the size of the largest load you will be moving.
- Do not drag the wire rope through dirt or debris that could cause damage, or poor operation.

⚠WARNING

Install the wire rope securely to the winch drum. A poorly secured wire rope could come loose from its anchor and allow the load to fall.

- 1.4.1 DETERMINE WHICH DIRECTION the drum must rotate to wind and unwind wire rope.
- 1.4.2 PURCHASE THE PROPER WIRE ROPE for your application. Keep the following in mind when selecting a wire rope. Contact a reputable wire rope supplier for help.
 - a BREAKING STRENGTH of new wire rope should be at least 3 times greater than the largest load placed on the winch. If loads are lifted or dragged on an incline, the breaking strength must be at least 5 times greater than the largest load. These are minimum values and will vary with the type of load and how you are moving it.
 - b WIRE ROPE LAY must agree with the winding direction of the drum to help insure proper winding. We recommend regular right lay for most applications.
 - c WE RECOMMEND 7 x 19 galvanized aircraft cable for diameters up to 5/16 inch, and 6 x 37 IWRC improved plow steel wire rope for diameters of 3/8 inches and up.
- 1.4.3 INSERT THE END OF THE WIRE ROPE into the cable anchor, until at least 1/2 inch of rope extends out the other side. See figure 3.
- 1.4.4 TIGHTEN THE SET SCREW until it flattens the wire rope against the anchor hole. Use enough force to drive the point of the set screw securely into the wire rope.
- 1.4.5 WIND FOUR FULL WRAPS of wire rope onto the drum by operating the winch while holding the wire rope taught. **These wraps serve as anchor wraps and must remain on the drum at all times.**

Figure 3 – Installing the Wire Rope

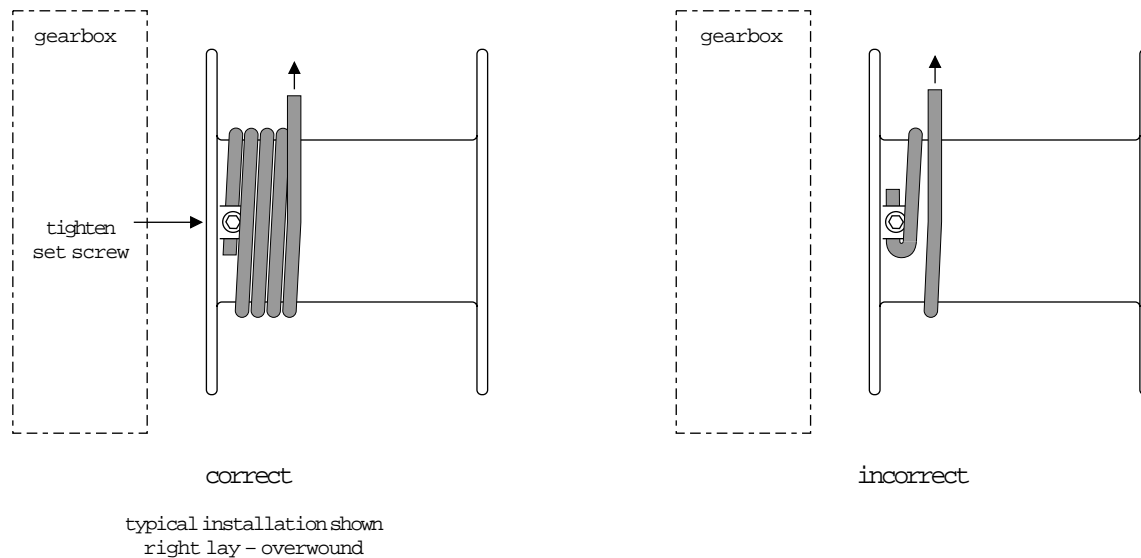

2.1 General Theory of Operation

Important!

- Limit nonuniform winding by keeping tension on the wire rope and by maintaining the proper fleet angle.
- It is your responsibility to detect and account for different factors affecting the condition and performance of the equipment.

- 2.1.1 THE PULL REQUIRED to move the load must not exceed the load rating of the winch. Consider the total force required to move the load, not the weight of the load.
- 2.1.2 THIS EQUIPMENT CAN develop forces that will exceed the load rating. It is the responsibility of the equipment user to limit the size of the load. Inspect the equipment regularly for damage according to the instructions contained in this manual.
- 2.1.3 USE A LOAD BRAKE on all winches used to lift loads or drag loads on an incline. Although a new winch may appear to hold the load in place, this characteristic will diminish with use. **Do not depend on worm gearing to hold the load in place.**
- 2.1.4 PERFORMANCE RATINGS of the equipment are affected by the amount of wire rope wound on the drum, the way in which it is wound, and the way the winch is used.
- a DRUM CAPACITY depends on how tightly and evenly the wire rope is wound on the drum. Actual drum capacities are usually 25-30% less than values shown in performance tables, due to loose winding and overlapping.
 - b LINE SPEED increases with each additional layer of wire rope wound onto the drum. The weight of the load does not affect line speed.
 - c LOAD RATING represents the maximum pull that can be placed on new equipment. Load ratings are assigned values for specific amounts of load travel or wire rope accumulation. The load rating decreases as layers of wire rope accumulate on the drum.
- 2.1.5 DUTY RATINGS refer to the type of use the equipment is subject to. Consider the following when determining duty rating.
- a ENVIRONMENT: harsh environments include hot, cold, dirty, wet, corrosive, or explosive surroundings. **Protect the equipment from harsh environments when possible.**
 - b MAINTENANCE: poor maintenance, meaning poor cleaning, lubrication, or inspection, leads to poor operation and possible damage of the equipment. **Minimize poor maintenance by carefully following the instructions contained in this manual.**
 - c LOADING: severe loading includes shock loading and moving loads that exceed the load rating of the equipment. **Avoid shock loads, and do not exceed the load rating of the equipment.**
 - d FREQUENCY OF OPERATION: frequent start and stop functions increase wear and shorten the life span of the gear train and load brake components. Lengthy operations cause lubrication to become hot, which also decreases the life span of the gear train. **Increase maintenance of the equipment if used in frequent operations.**

CONTACT THE FACTORY FOR MORE INFORMATION.

2.2 Suggestions for Safe Operation

⚠WARNING**DO the following:**

Keep at least 4 wraps of wire rope wound on the drum at all times, to serve as anchor wraps. With less than 4 wraps on the drum the wire rope could come loose, causing the load to fall.

Keep hands away from the drum, wire rope, and other moving parts of the equipment.

Equip the winch with a load brake if it is used to lift loads, or drag loads on an incline.

Keep all people, including operators and yourself, away from the winch. Keep out of the path of the load, and out of the path of a broken wire rope that might snap back and cause injury.

DO NOT do the following:

Do not lift people, or things over people. Do not walk or work under a load or in the line of force of any load.

Do not exceed the load rating of the winch or any other component in the system. To do so could result in failure of the equipment.

Do not use more than one winch to move a load that exceeds the load rating of a single winch. A shift in load weight could overload the equipment.

Do not use damaged or malfunctioning equipment. To do so could result in failure of the equipment.

Do not modify the equipment in any way. To do so could cause equipment failure.

Do not operate the winch with guards removed or improperly installed.

Do not divert your attention from the operation. Stay alert to the possibility of accidents, and try to prevent them from happening.

Do not jerk or swing the load. Avoid shock loads by starting and stopping the load smoothly. Shock loads overload the equipment and may cause damage.

Do not leave a suspended load unattended. Place the load on the ground before leaving it unattended.

2.3 Breaking-In the Winch

- 2.3.1 BREAK-IN OCCURS during the first 10 hours of normal operation. During break-in, mating surfaces become polished, and clearances increase. This is desired for efficient operation of bearings and gears.
- 2.3.2 INSPECT THE WINCH following break-in according to the Instructions for Periodic Inspection.

2.4 Preparing for Operation

Important!

- When determining whether the load will exceed the load rating, consider the total force required to move the load.

- 2.4.1 CONSIDER THE OPERATION. Do not begin until you are sure you can perform the entire operation without hazard.
- 2.4.2 INSPECT ALL COMPONENTS of the system.
- INSPECT THE WINCH and other equipment according to the Instructions for Frequent Inspection.
 - OPERATORS must be in good health, alert, thoroughly trained in operating the equipment, and properly clothed (hard hat, safety shoes and safety glasses, no loose clothing).
 - THE LOAD must be clear of other objects and free to move. Make sure the load will not tip, spin, roll away, or in any way move uncontrollably.
- 2.4.3 KNOW YOUR LOAD and make sure you do not exceed the load rating of the winch or any other equipment in the system.

2.5 Attaching the Load

⚠WARNING

Do not wrap the wire rope around the load. This damages the wire rope and could cause the load to fall. Use a sling or other approved lifting device.

- 2.5.1 CLEAR OBJECTS from the path of the load so you can move it freely and observe it at all times during the operation.
- 2.5.2 ATTACH THE LOAD using a nylon sling, or other approved lifting device. Follow the recommendations of the sling manufacturer.
- SEAT THE SLING in the saddle of the hook with the hook latch completely closed. See figure 4.
 - CENTER THE LOAD on the hook so it will remain balanced and not tip or rotate to one side.

Figure 4 – Attaching Load

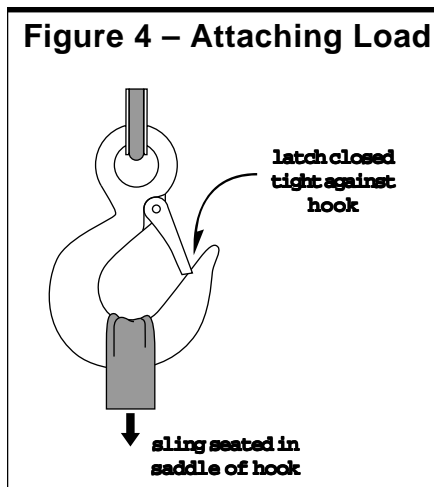

2.6 Moving the Load

Important!

- Obey a stop signal from anyone.
- Maintain tension on the wire rope to keep it tightly and evenly wound on the drum.
- If the winch and load are not visible during the entire operation, get help from another person.
- Appoint a supervisor if more than one person is involved in the operation. This will reduce confusion and increase safety.
- When lifting a load, use a metal rod, wooden stick, or rope to keep the load from swinging or twisting, while keeping yourself away from the load.

- 2.6.1 MOVE THE LOAD slowly and smoothly, only a small distance at first. Make sure the load is balanced and securely attached before continuing.
- 2.6.2 MANUAL OPERATION.
- a TURN THE HANDLE to wind or unwind wire rope from the drum.
- b GRIP THE HANDLE TIGHTLY during operation. If you release the handle the load may drop causing the handle to spin. **Do not try to stop a spinning handle, step clear until the spinning stops.**
- 2.6.3 POWER OPERATION.
- a USE THE CONTROL DEVICE to operate the winch. The control device should be momentary contact type, so the winch will stop when the operator releases the control.
- b OBSERVE THE GEARBOX during operation for signs of overheating. **Frequent overheating may be a sign of damage, or may indicate the need for a larger power winch.**
- WATCH FOR SMOKE, the smell of burnt lubricant, and other signs of overheating. Use a thermocouple or other device to monitor gearbox temperature.
 - STOP THE OPERATION if the gearbox overheats, and allow the winch to cool. **Continued operation may cause damage.**
- 2.6.4 OBSERVE THE WIRE ROPE as it winds onto the drum. If it becomes loose, uneven, or overlapped, stop the operation and rewind the wire rope before continuing. **Continued operation with overlapped or uneven wire rope can damage the wire rope and shorten its life.**

3.1 Cleaning the Winch

Important!

Increase the frequency of maintenance procedures if the winch is:

- Operated for long periods.
- Used to pull heavy loads.
- Operated in wet, dirty, hot, or cold surroundings.

Clean the winch to remove dirt and help prevent rust and corrosion.

- 3.1.1 CLEAN THE WINCH every six months or whenever it is dirty.
 - a WIPE ALL EQUIPMENT with an oily rag to remove dirt and grease.
 - b LEAVE A LIGHT FILM of oil on all surfaces to protect them against rust and corrosion.
 - c WIPE OFF excessive amounts of oil to avoid the accumulation of dirt.
- 3.1.2 REMOVE ALL UNNECESSARY OBJECTS from the area surrounding the winch.

3.2 Adjusting the Electric Brake

⚠WARNING

Do not adjust the brake with the load suspended. Accidental release of the brake could cause the load to fall.

Figure 5 – Adjusting the Electric Brake

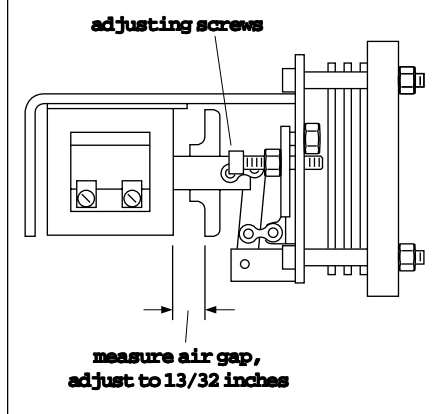

- 3.2.1 ADJUST THE BRAKE every 6 months or whenever it needs adjustment.
- 3.2.2 CHECK THE BRAKE by operating the winch with a test load equal to the load rating.
 - a RAISE THE LOAD, then lower it and stop it about one foot off the ground.
 - b OBSERVE THE LOAD when stopped.
 - If it comes to a complete halt without coasting, the brake does not need adjustment.
 - If the load continues to coast or creep, lower the load and adjust the brake.
 - Repeat the test following adjustment. If the brake continues to fail, you may need to replace the solenoid or friction discs.
- 3.2.3 ADJUST THE BRAKE by adjusting the air gap in the solenoid.
 - a DISCONNECT ELECTRIC POWER SUPPLY.
 - b REMOVE THE BRAKE COVER by following instructions under Disassembling the Winch.
 - c MEASURE AIR GAP by placing a rule across the top of the solenoid. The air gap should measure between 13/32 and 15/32 inches.
 - d ADJUST THE AIR GAP, if necessary, by turning the adjusting screws until the gap measures 13/32 inches. See figure 5.
 - e REASSEMBLE THE BRAKE by following instructions under Reassembling the Winch.

3.3 Lubricating the Winch

Important!

- Do not leave plug holes in the gearbox open. Open plug holes will allow dirt and moisture to contaminate the lubrication.
- Make sure lubricant has a temperature rating appropriate for the ambient temperatures of the operation.

Table 1 – Lubrication

ambient temp.	15°-60° F	50°-125° F
AGMA	grade 7	grade 8
474 gearbox capacity		1/2 pint
484 gearbox capacity		2 pints

Figure 6 – Lubricating the Winch

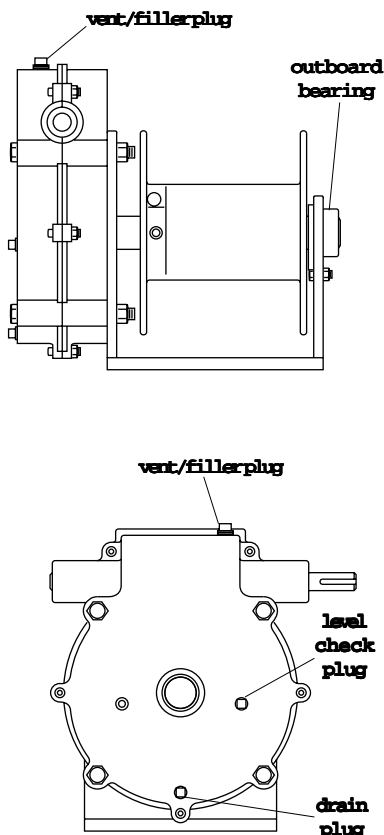

⚠ WARNING

Make sure the vent/filler plug is clean and open to vent heat and pressure. Poor ventilation may cause overheating and result in damage to oil seals and other equipment.

Fill the speed reducer to the proper level without overfilling. Too much or too little lubricant will cause overheating and result in damage to seals, bearings, and gears.

The winch is shipped without oil in the gearbox. Lubricate the winch properly to help protect it from wear and rust. Read the following instructions carefully.

- 3.3.1 CONSULT MANUFACTURER'S RECOMMENDATIONS for specific information on lubricating the motor, wire rope, and other equipment.
- 3.3.2 LUBRICATE THE DRIVE TRAIN as recommended by the drive train manufacturer.
- 3.3.3 FILL THE GEARBOX with oil before every operation, and every 10 hours during operation. See figure 6.
 - a USE 90 WEIGHT GEAR OIL to fill the gearbox. Use an oil with a small percentage of acid free tallow. **Do not use extreme pressure lubricants and do not mix incompatible oils in the gearbox.**
 - b REMOVE THE VENT/FILLER PLUG located on top of the gearbox, and the level check plug located on the side.
 - c FILL THE GEARBOX until oil reaches the level check plug. Use a funnel to pour oil into the vent/filler plug hole.
 - d REPLACE THE LEVEL CHECK PLUG and the vent/filler plug. Make sure the vent/filler plug is clean and open.
- 3.3.4 CHANGE GEARBOX OIL when it is dirty, full of metal particles, or otherwise contaminated. Remove the drain plug to drain oil from the gearbox. See figure 6.
- 3.3.5 LUBRICATE THE OUTBOARD BEARING at least every 10 hours of operation. See figure 6.
 - a USE 150 GRADE GEAR OIL to lubricate the outboard bearing.
 - b USE AN OIL CAN to place 2 to 3 drops of oil into the hole in the bearing housing. Rotate the drum 1/2 revolution and add 2 to 3 more drops of oil.
- 3.3.6 LUBRICATE THE WIRE ROPE by following the wire rope manufacturer's recommendations.

3.4 Inspecting the Equipment

Important!

- Start an inspection program as soon as you put the winch into use.
- Appoint a qualified person to be responsible for regularly inspecting the equipment.
- Keep written records of inspection. This allows comparison with comments from previous inspections so you can see changes in condition or performance.

Perform frequent inspections:

- Before each operation.
- Every 3 hours during operation.
- Whenever you notice signs of damage or poor operation.

⚠WARNING

Do not use damaged or malfunctioning equipment. Place an “OUT OF ORDER” sign on the winch. Do not use the winch until the sign is removed by a qualified maintenance person who has completely corrected the problem.

Inspect the winch to detect signs of damage or poor operation before they become hazardous.

3.4.1 CONSULT APPLICABLE CODES AND REGULATIONS for specific rules on inspecting the winch and other equipment.

3.4.2 CONSULT MANUFACTURER’S RECOMMENDATIONS for information on inspecting the motor, drive train, wire rope, and other equipment.

3.4.3 Instructions for Frequent Inspection

- a VISUALLY INSPECT the entire winch and all other equipment involved in the operation.
 - Check all equipment for cracks, dents, bending, rust, wear, corrosion and other damage.
 - Make sure the wire rope is installed correctly and anchored securely to the drum.
 - Check the gearbox for signs of leakage, and make sure it is filled with the proper oil.
 - Make sure the vent/filler plug is clean, open, and installed properly.
 - Make sure all guards are securely fastened in place, and free of damage.
 - Make sure mounting fasteners are tightened securely.
 - Make sure the foundation is in good condition, and capable of supporting the winch and its load under all load conditions.
 - Check power supply lines and connections for wear, corrosion, cuts, and other damage.
- b TEST WINCH PERFORMANCE by moving a test load of 100 pounds.
 - Listen for unusual noises, and look for signs of damage as you operate the winch.
 - Make sure the wire rope winds evenly and tightly onto the drum. If it is loose or uneven, rewind it before continuing.
 - Make sure the load moves smoothly, without hesitation or strain.
 - Make sure the winch responds to the control device. It must rotate as shown on the control labels, and it must turn off when you release the control.
 - Check the brake. Raise the load, then lower it and stop it a few feet off the ground. If the load continues to coast or creep, the brake needs adjustment.

Completely correct all problems before continuing. Use the Troubleshooting Chart to help determine the cause of certain problems. See table 3.

Perform periodic inspections:

- Every 6 months.
- Whenever you return the winch to service from storage.
- Whenever you notice damage or poor operation in a frequent inspection.
- Whenever you have, or think you may have, overloaded or shock loaded the winch.

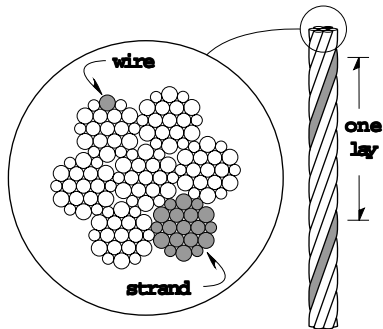
Figure 7 – Broken Wires

Wire rope assembly must be replaced if more than 6 wires are broken in one lay, or if more than 3 wires are broken in one strand in one lay.

3.4.4 Instructions for Periodic Inspection

- a **VISUALLY INSPECT** the winch and all other equipment.
 - Check the finish for wear, flaking, or other damage.
 - Check all equipment for cracks, dents, bending, rust, wear, corrosion and other damage. If the winch was overloaded, or if you notice cracks and other signs of overloading, check for damage using magnetic or chemical crack detecting procedures.
 - Make sure all labels and plates are readable, firmly attached, free of damage and clean. Replacements are available from the factory.
 - Check the gearbox for signs of leakage.
- b **REMOVE THE WINCH FROM THE FOUNDATION.**
 - Check fasteners for stripped threads, wear, bends, and other damage.
- c **DRAIN A SMALL AMOUNT OF OIL** into a clean container.
 - Check the oil for dirt, metal particles, water, and other signs of contamination. Completely drain the gearbox if oil is contaminated.
- d **FILL THE GEARBOX** with the proper type of lubricant.
- e **REMOVE THE WIRE ROPE** entirely from the drum.
 - Check the entire length of wire rope for bent wires, crushed areas, broken or cut wires, corrosion, and other damage. Carefully inspect areas that pass over sheaves or through roller guides.
 - Note the location and concentration of broken wires. Replace wire rope if more than 6 wires are broken in one lay, or more than 3 wires are broken in one strand in one lay. See figure 7.
 - Make sure the load hook or other device is securely attached to the wire rope, and the wire rope where it is attached is not frayed, corroded, broken, or otherwise damaged.
 - Measure the throat opening, thickness, and twist of the hook. Replace the hook if it shows signs of damage. See figure 8.
 - Make sure hook latch opens without binding and closes when released.
 - Check the anchor holes in the drum and the surrounding area for signs of wear or distortion.
- f **MOVE THE DRUM** with your hands.
 - Check for excessive movement indicating worn or loose gears or bearings. Slight end play in the drive shaft is normal. Excessive movement is caused by overloading or overheating, and is a sign that your application may require a larger power winch.
 - Disassemble the winch if necessary. Inspect gears, keys, bearings, seals, and shafts for wear, distortion, and other damage.

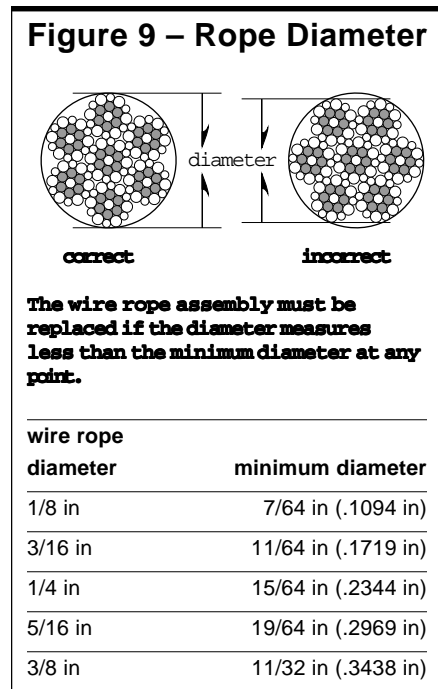
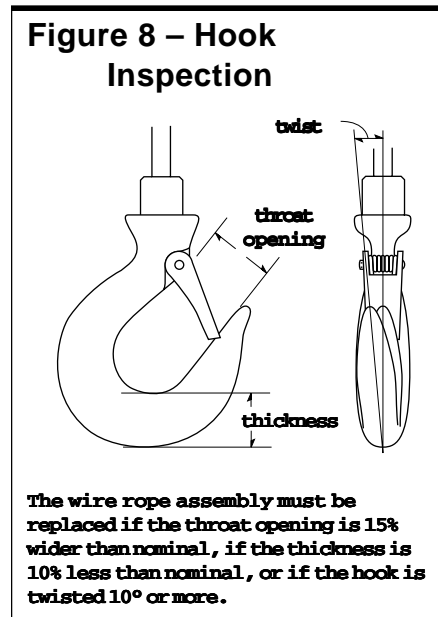

- g REMOVE THE DRIVE TRAIN GUARD and inspect the drive train.
 - Check tension and alignment of drive train components and adjust if necessary.
 - Check drive train components for cracks, wear, corrosion, and other damage.
- h INSTALL THE DRIVE TRAIN GUARD, and make sure it is free of damage.
- i PLACE 100 POUNDS of tension on the wire rope.
 - Measure the diameter of the wire rope, especially in areas where wear is noticeable. Replace the wire rope if the diameter measures below the minimum diameter at any point. See figure 9.
- j FASTEN THE WINCH SECURELY TO THE FOUNDATION.
- k INSTALL THE WIRE ROPE.
- l TEST WINCH PERFORMANCE by operating the winch with a test load equal to the load rating.
 - Listen for unusual noises, and look for signs of damage as you operate the winch.
 - Make sure the wire rope winds evenly and tightly onto the drum. If it is loose or uneven, rewind it before continuing.
 - Observe the rotating drum, look for signs of loose or misaligned bearings.
 - Make sure the winch responds to the control device. It must rotate as shown on the control labels, and it must turn off when you release the control.
 - Make sure the load moves smoothly without hesitation or strain.
 - Check the brake. Raise the load, then lower it and stop it a few feet off the ground. If the load continues to coast or creep, the brake needs adjustment.
- m DISCONNECT POWER and inspect power supply lines, the motor, and controls.
 - Check all power lines for wear, cuts, corroded connections, and other damage.
 - Check power supply at the motor, make sure it agrees with the motor rating.
 - Check the control device and other equipment for signs of moisture, corrosion, burn marks, cracks, and other damage.
- n CONNECT POWER.

Completely correct all problems before continuing. Use the troubleshooting chart to help determine the cause of certain problems. See table 3.

Table 3 – Troubleshooting Chart

problem	cause	correction
motor won't run	<ul style="list-style-type: none"> • overload switch or valve tripped • power connections loose or damaged • power supply failure • motor burnt out or damaged 	<ul style="list-style-type: none"> reset overload switch or valve inspect, repair and tighten as necessary inspect and repair as necessary repair or replace as necessary
motor runs, drum doesn't turn	<ul style="list-style-type: none"> • broken drum spring pin • loose or broken gears or keys • broken or damaged drive train 	<ul style="list-style-type: none"> inspect and replace as necessary inspect and replace as necessary inspect and repair as necessary
handle turns hard or does not turn or motor tries to turn but can't	<ul style="list-style-type: none"> • unit overheated • load too heavy • poor power supply at motor • load brake not operating properly • gears or bearings broken or locked 	<ul style="list-style-type: none"> allow to cool lighten load inspect and repair as needed inspect and repair as necessary inspect and replace as necessary
brake does not operate properly	<ul style="list-style-type: none"> • manual release lever in release position • power to brake incorrect • brake adjusted incorrectly • friction discs worn or damaged • solenoid damaged • brake components seized up or damaged 	<ul style="list-style-type: none"> move to lock position check power, repair as needed adjust brake inspect and replace as necessary inspect and replace as necessary inspect and repair as necessary
oil leakage	<ul style="list-style-type: none"> • worn bearings • damaged oil seals or gasket cement • cracked or damaged gearbox 	<ul style="list-style-type: none"> inspect and replace as necessary inspect and replace as necessary inspect and repair as necessary
excessive end play on drive shaft	<ul style="list-style-type: none"> • thrust washer worn out • excessively worn gears 	<ul style="list-style-type: none"> inspect and replace as necessary inspect and repair as necessary
excessively worn gears or bearings (excessive backlash)	<ul style="list-style-type: none"> • load too heavy • poor lubrication of gearbox or bearings 	<ul style="list-style-type: none"> lighten load inspect and lubricate as necessary
overheating	<ul style="list-style-type: none"> • operated too long without rest • load too heavy • poor lubrication • vent plug clogged or damaged • bearing seized up 	<ul style="list-style-type: none"> allow to cool lighten load inspect and lubricate as necessary clean or replace vent plug as needed inspect and replace as necessary
unusual noises		
high pitched squeak	<ul style="list-style-type: none"> • poor lubrication 	inspect and lubricate as necessary
grinding noise	<ul style="list-style-type: none"> • contaminated lubrication • broken gears or bearings • drive train misaligned 	<ul style="list-style-type: none"> drain, clean and lubricate the winch inspect and replace as necessary adjust tension and alignment
whining motor	<ul style="list-style-type: none"> • load too heavy • motor overheated • motor bearings burnt out 	<ul style="list-style-type: none"> lighten load allow to cool replace motor or bearings
rattling noise	<ul style="list-style-type: none"> • loose bolts or set screws 	tighten all bolts and screws
heavy thump during operation	<ul style="list-style-type: none"> • contaminants in oil • loose set screws or keys in gears • bearings defective 	<ul style="list-style-type: none"> drain, clean and lubricate the winch inspect and repair as necessary inspect and replace as necessary
heavy thump as unit starts to turn	<ul style="list-style-type: none"> • thrust bearing defective 	inspect and replace as necessary

3.5 Disassembling the Winch

Important!

- Discard all spring pins, retaining rings, and oil seals. Replace with new ones during reassembly.

Disassemble the winch to inspect or repair gears, bearings, and other parts.

- 3.5.1 REMOVE THE WIRE ROPE completely from the drum.
- 3.5.2 DISCONNECT POWER SUPPLY.
- 3.5.3 DRAIN THE GEARBOX completely.
- 3.5.4 DISASSEMBLE THE DRIVE TRAIN or remove the handle.
- 3.5.5 DISCONNECT THE MOTOR, CONTROLS, and other equipment.
- 3.5.6 DISASSEMBLE THE BRAKE, if applicable.
 - a DISCONNECT ELECTRIC POWER SUPPLY, if you have not done so.
 - b LOOSEN THE SCREWS on the connector securing the electric cable to the brake cover.
 - c REMOVE THE MANUAL RELEASE SCREW.
 - d REMOVE THE COVER by removing the screw fastening it to the brake, and carefully pulling the cover straight off the brake body. The cover will still be attached to the electric cable.
- 3.5.7 DISASSEMBLE THE BRAKE SOLENOID ASSEMBLY, if you need to replace the friction discs or the solenoid.
 - a REMOVE THE SUPPORT PLATE from the end plate, and remove the stationary discs and old friction discs.
 - b CUT ELECTRICAL WIRES connected to the faulty solenoid, and remove the solenoid from the support plate.
 - c REMOVE THE CONNECTING LINK by separating the lever from the lever arm with a screwdriver.
 - d REMOVE THE SOLENOID and replace if necessary.
- 3.5.8 DISASSEMBLE THE DRUM AND GEARBOX ASSEMBLY.
 - a REMOVE THE GROOVED PIN fastening the drum to the drum shaft.
 - b REMOVE THE FASTENERS to separate the gearbox from the winch frame.
 - c DISASSEMBLE THE GEARBOX. A gasket cement is used during assembly, and you may need to strike the drive shaft with a soft faced hammer to break this seal.
 - d DISASSEMBLE THE GEARS by loosening the set screws. Make sure to keep each key with the proper gear.
- 3.5.9 REMOVE THE OUTBOARD BEARING from the frame and use a bearing press to remove the bronze bearing from the bearing holder.

3.6 Reassembling the Winch

Important!

- During reassembly, use **Permatex 2C Form-a-Gasket** to create a seal between the two halves of the gearbox.

- 3.6.1 **INSTALL THE OUTBOARD BEARING** and seat the slot in the bearing holder over the capscrew in the frame. You will first need to use a bearing press to install a new bearing if you removed the old one.
- 3.6.2 **REASSEMBLE THE GEARBOX.**
 - a **REMOVE OLD GASKET CEMENT** to help prevent oil leakage.
 - b **REASSEMBLE THE WORM** and worm gear to the proper shafts with the correct keys and set screws.
 - c **MESH THE WORM** and the worm gear teeth together, and fit this assembly into the gearbox.
 - d **REASSEMBLE THE GEARBOX** by applying gasket cement to the rim of one gearbox half, then fastening the two halves together.
- 3.6.3 **REASSEMBLE THE DRUM AND GEARBOX ASSEMBLY.**
 - a **SLIDE THE DRUM SHAFT** through the frame, through the drum, and into the outboard bearing.
 - b **FASTEN THE GEARBOX** to the winch frame.
 - c **SECURE THE DRUM** to the drum shaft with a new grooved pin.
- 3.6.4 **REASSEMBLE THE DRIVE TRAIN**, adjust tension and alignment, and install drive train guards.
- 3.6.5 **REASSEMBLE THE BRAKE, IF APPLICABLE.**
 - a **INSTALL NEW FRICTION DISCS**, if necessary, and make sure they slide freely on the hub.
 - b **INSTALL STATIONARY DISCS** and attach the end plate to the support plate.
 - c **INSTALL SOLENOID**, if necessary, by attaching the solenoid plunger to the lever with the connecting link, and attaching the solenoid to the support plate.
 - d **CONNECT THE ELECTRIC LEADS** to the solenoid by stripping the insulation back about 1/2 inch.
 - e **ADJUST THE BRAKE** by adjusting the air gap in the solenoid.
 - f **INSTALL THE BRAKE COVER.**
 - g **INSTALL THE MANUAL RELEASE SCREW.**
 - h **TIGHTEN SCREWS** on the connector securing the electric cable to the cover.
- 3.6.6 **CONNECT THE MOTOR, CONTROLS**, and all other equipment.
- 3.6.7 **COMPLETE ASSEMBLY**, and return the winch to service.
 - a **LUBRICATE THE ENTIRE WINCH.**
 - b **INSTALL POWER.**
 - c **INSTALL THE WIRE ROPE.**
 - d **INSPECT THE WINCH** according to the Instructions for Frequent Inspection.

3.7 Repairing the Winch

Important!

- It is your responsibility to determine when to replace parts. When considering whether to continue using a part or to replace it, remember that replacing it is the best way to avoid further equipment damage.
- Replace impregnated oil bearings and oil seals when you replace gears, or when damaged by age or overheating.
- Appoint a qualified person to be responsible for all repairs to the equipment.

- 3.7.1 GET FACTORY AUTHORIZATION for all repairs. Unauthorized repairs will void the warranty, and may lead to damage or failure of the winch.
- 3.7.2 REPLACE DAMAGED OR POORLY OPERATING PARTS with Thern repair parts.
- 3.7.3 REFINISH AREAS where the paint is worn or flaking. A good finish helps to protect against corrosion and weather damage.
- a REMOVE THE FINISH from damaged areas, down to the bare metal.
 - b CLEAN THE AREA thoroughly.
 - c REPAINT with a high quality primer and finishing coat.
- 3.7.4 TO ORDER REPAIR PARTS, contact your local dealer. Include the following information when ordering:
- model number
 - serial number (or code number)
 - part number
 - date purchased, and from whom
 - description of what happened, or what is wrong
 - your name and return address

4.1 Transporting the Winch

Important!

- Keep a record of what you ship, and when you send it.

- 4.1.1 DRAIN OIL from the gearbox.
- 4.1.2 PACK THE WINCH in an upright position for transport, using the original packaging materials, if possible.
 - a FASTEN THE WINCH TO A WOODEN BASE using lag bolts, to keep it from moving during transport.
 - b SEAL THE WINCH in plastic with a desiccant to help protect it from rust, corrosion, and other damage.
 - c CONSTRUCT WOODEN SIDES and top to enclose the winch in a solid protective crate.
 - d PACK LOOSE PARTS in small boxes or ship separately.
- 4.1.3 INSPECT THE WINCH according to the Instructions for Periodic Inspection before installing it in a new location.

4.2 Storing the Winch

- 4.2.1 FILL THE GEARBOX with oil, and make sure the vent/filler plug is clean and properly installed.
- 4.2.2 SEAL THE WINCH in plastic with a desiccant to help protect it from rust, corrosion, and other damage.
- 4.2.3 STORE THE WINCH upright, in a cool clean place away from corrosive chemicals and moisture.
- 4.2.4 ROTATE THE DRUM PERIODICALLY to keep bearing and gears surfaces from becoming lacquered. Release the brake to rotate the drum.
- 4.2.5 INSPECT THE WINCH according to the Instructions for Periodic Inspection before installing it for operation.

B473 and B483 Electric Brake			
item	description	part number	qty.
1	support plate weldment	B1140	1
2	lever arm weldment	B1133	1
3	lever	A1346	1
4	hub	A1344	1
5	end plate	A1345	1
6	solenoid	Varies - Specify Voltage	1
7	cover	B1135	1
8	friction disc	A1138	2
9	stationary disc	A1339	3
10	spacer	A1340	4
11	pressure spring	A1343	2
12	connecting link	A1354	1
13	double connecting link	A1341	1
14	spring pin	A4032	1
15	spring pin	A2849	1
16	oilite bearing	A3647	1
17	capscrew	A3444	4
18	capscrew	A3288	2
19	machine screw	A3879	4
20	machine screw	A3876	1
21	machine screw	A2814	1
22	capscrew	A3449	2
23	hex nut	A3569	5
24	hex nut	A3200	5
25	lock nut	A3315	4
26	set screw	A3748	2
27	terminal	A4889	3
28 ¹	retaining ring (Spirolox)	A3807	1
29 ¹	machinery bushing	A3910	1
30 ¹	2 screw connector	A4391	1
31 ¹	capscrew	A3144	1
32 ¹	lock washer	A3596	1
33 ^{1,2}	brake mounting bracket	B1246	1
34 ^{1,3}	brake mounting bracket	C1137	1

¹ Items 28, 29, 30, 31, 32, 33, and 34 are not shown on the drawing.

² Item 33 for use on B473 only.

³ Item 34 for use on B483 only.

B473W and B483W Weatherproof Electric Brake			
item	description	part number	qty.
1	support plate weldment	B1140	1
2	lever arm weldment	B1133	1
3 ²	bearing end plate	C1080	1
4	bearing seal	A4377	1
5	oilite bearing	A3654	1
6	"O" ring	A4884	2
7	hub	A1344	1
8	stationary disc	A1339	3
9	friction disc	A1138	2
10	spring pin	A2849	1
11	spacer	A1340	4
12	solenoid	Varies - Specify Voltage	1
13	lever	A1346	1
14	spring pin	A4032	1
15	connecting link	A1354	1
16	double connecting link	A1341	1
17	release pin	A1337	1
18	release pin knob	A4715	1
19	release pin seal	A4887	1
20	seal holder	A1347	1
21	cover	B1141	1
22 ²	connector end plate	C1154	1
23	strain relief connector	A4508	1
24	cover screw	A1359	2
25	hex nut	A3200	16
26	pressure spring	A1343	2
27	capscrew	A3449	2
28	capscrew	A3288	2
29	hex locknut	A3315	4
30	capscrew	A3444	4
31	machine screw	A3879	4
32	hex nut	A3569	4
33	set screw	A3748	2
34	screw seal	A4885	4
35	mounting screw	A1358	2
36 ¹	retaining ring	A3807	1
37 ³	bearing end plate	C1083	1
38 ³	connector end plate	C1084	1
39	lock washer	A3075	8
40	shakeproof lock washer	A3596	4
41	terminal	A4889	3
42 ¹	machinery bushing	A3910	1
43 ^{1,2}	brake mounting bracket	C1071	1
44 ^{1,3}	brake mounting bracket	C1072	1
45 ^{1,2}	capscrew	A3501	1

¹ Items 36, 42, 43, 44, and 45 are not shown on the drawing.

² Item 3, 22, 43, and 45 for use on B473W only.

³ Item 37, 38, and 44 for use on B483W only.

474 Worm Gear Winch			
item	description	part number	qty.
1	drive shaft	A1495	1
2	square key	A3255	1
3	worm	A1497	1
4	ball thrust bearing	A1498	2
5	oilite bearing	A3656	2
6	oil seal	A4355	2
7	worm gear	A1500	1
8	set screw	A3260	1
9	square key	A1167	1
10	drum shaft	B1215	1
11	oilite bearing	A3640	2
12	oil seal	A4356	2
13	drum	B1214	1
14	groove pin	A2557	1
15	set screw	A3259	1
16	bearing housing	A1499	1
17	oilite bearing	A3644	1
18	frame	C1109	1
19	hex nut	A3200	2
20	hex nut	A3250	4
21	inside gearcase	C1339	1
22	outside gearcase	C1339	1
23	cap screw	A4568	2
24	cap screw	A3404	4
25	pipe plug	A3407	2
26	square head "L" vent	A3408	1
27	set screw	A3746	1
28	shim set	A1928	2
29	pipe plug	A4585	3
30	capscrew	A3032	1
31	hex lock nut	A2927	1

484 Worm Gear Winch			
item	description	part number	qty.
1	drive shaft	B1051	1
2	square key	A2363	1
3	worm	A1497	1
4	spacer	A1134	2
5	ball thrust bearing	A1498	2
6	bushing	A1502	2
7	oilite bearing	A3651	4
8	oil seal	A4377	2
9	worm gear	C1117	1
10	set screw	A3260	1
11	square key	A3253	2
12	drum shaft	B1217	1
13	oilite bearing	A3631	2
14	oil seal	A4378	2
15	outside gearcase	C1398	1
16	inside gearcase	C1398	1
17	cap screw	A3247	4
18	hex nut	A3227	4
19	cap screw	A3288	5
20	hex nut	A3200	5
21	pipe plug	A3407	2
22	square head "L" vent	A3408	1
23	drum weldment	C1076	1
24	groove pin	A2558	1
25	frame weldment	C1113	1
26	set screw	A3128	1
27	bearing housing	A1503	1
28	oilite bearing	A3636	1
29	set screw	A3244	1
30	cap screw	A3032	1
31	nylock jam nut	A2927	1
32	shim set	A2671	2
33	pipe plug	A3405	3

