



PORTABLE ELECTRIC CAPSTAN WINCH

LIBERTY[®] SERIES



thern.com
(507) 454-2996

LIBERTY® SERIES

PORTABLE CAPSTAN WINCH W/ INTEGRAL SWIVEL BASE



Quiet Performance and Long Life at Any Angle

The Thern Liberty® Series capstan winch delivers portable strength and performance. More importantly, quiet operation enhances team communication for increased productivity. A powder-coat finish and corrosion-resistant components ensure dependable operation for many years. The swivel base allows operation at almost any angle—especially when paired with the optional hitch mount. Position your truck once, rotate the winch (15° increments) to align the load, and lock it down. It's perfect for energy sector tasks in remote locations, including pole setting, stringing lines, maintaining wind turbines, and erecting cell towers.

Engineered Drum Design

- Keeps load line from moving during operation, enhancing productivity
- Nickel-plated steel construction for optimum performance and durability

Integral Rope Keep

- Spring-loaded rope keep helps prevent accidental removal of hand line from drum
- Corrosion-resistant components improve durability
- Rope keep bar serves as a carrying handle

Premium Motor with Handle

- Premium motor offers quiet operation (80 dBA)* enhancing clear communication between operators
- Durable powder-coat finish resists contamination for increased reliability
- Maintenance-free, permanently lubricated, planetary gearbox for smooth operation and long life
- UL-Recognized motor

Foot Switch Control

- Foot switch-controlled operation delivers productivity and safety
- IP65, NEMA 4-rated sealed foot switch allows outdoor use
- Painted, cast-iron construction and anti-skid feet promote durability and stability for outdoor applications
- 10-foot cord and twist-lock plug design avoids untimely power disruption, increasing productivity

Durable Swivel Frame with Integral Lock Option Available

- Adjustable rotation in 15° increments to align loads and lock securely with swivel stop
- Lightweight, engineered design and steel construction provides portability
- Powder-coated steel finish resists wear and promotes durability
- Half-inch, Grade 5 mounting hardware enhances security
- Optional heavy-duty fixed mount frame

Integral Rope Lock

- Rope lock prevents unintentional lowering of load
- Nickel-plated and anodized components ensure durability and smooth handling of load.
- Adjustable rope lock accommodates various line exit angles and operator heights



Product Shown:
3CP1S-AFS

PERFORMANCE

Series	IMPERIAL								
	Maximum Capacity	Rope Diameter Range**	Maximum Line Speed Range***	Rated Current Draw	Input Voltage	Ship Weight	Ambient Operating Temperature Range	Duty Cycle	Mount Type
3CP1M-AFS	1,000 lbs	½–¾ in	35–50 fpm	15 amp	115V/1 Phase /50-60Hz	64 lbs	-4 °F– +105 °F	20 mins full load	Fixed
3CP1S-AFS	1,000 lbs	½–¾ in	35–50 fpm	15 amp	115V/1 Phase /50-60Hz	76 lbs	-4 °F– +105 °F	20 mins full load	Swivel
3CP2S-AFS	2,000 lbs	½–¾ in	13–20 fpm	15 amp	115V/1 Phase /50-60Hz	84 lbs	-4 °F– +105 °F	20 mins full load	Swivel

Series	METRIC								
	Maximum Capacity	Rope Diameter Range**	Maximum Line Speed Range***	Rated Current Draw	Input Voltage	Ship Weight	Ambient Operating Temperature Range	Duty Cycle	Mount Type
3CP1M-AFS	450 kg	13–19 mm	11–15 mpm	15 amp	115V/1 Phase 50-60Hz	29 kg	-20°C– +40°C	20 mins full load	Fixed
3CP1S-AFS	450 kg	13–19 mm	11–15 mpm	15 amp	115V/1 Phase 50-60Hz	34 kg	-20°C– +40°C	20 mins full load	Swivel
3CP2S-AFS	900 kg	13–19 mm	4–6 mpm	15 amp	115V/1 Phase 50-60Hz	38 kg	-20°C– +40°C	20 mins full load	Swivel

* Thern's 3CP1M-AFS winch has a maximum noise level of 80 dBA, averaging 10 dBA less than the competition, when measured at a distance of approximately three feet under similar conditions.

** Synthetic rope only. Available for purchase through Thern.

*** Load dependent.

Motor Safety Features

- Over-temperature light indicates high temperatures caused by overcurrent or environmental factors
- Integrated breaker automatically provides overload protection to extend life of equipment



NOTICE: These products are not for lifting people or things over people.

Refer to technical pages for detailed performance information.

OPTIONS & ACCESSORIES
LIBERTY® SERIES
 PORTABLE CAPSTAN WINCHES

TECHNICAL DRAWINGS & SPECIFICATIONS
LIBERTY® SERIES
 PORTABLE CAPSTAN WINCHES



Product Shown:
 3CP1S-HM

Liberty Capstan Hitch Mounts - sold separately

Model 3CP1S-HM

- Compatible with 3CP1S-AFS 1,000 pound capacity Liberty Capstan winch only
- Heavy-duty (ASTM-grade steel) construction
- For use on vehicles with 2-inch hitch receiver
- Hitch mount includes standard receiver clevis and cotter pins
- Red powder-coat finish
- Weighs approximately 26 pounds for easy handling

Model 3CP2S-HM

- Compatible with both 3CP1S-AFS 1,000 pound capacity and 3CP2S-AFS 2,000 pound capacity Liberty Capstan winches
- Heavy-duty (ASTM-grade steel) construction
- For use on vehicles with 2 1/2-inch hitch receiver
- Hitch includes standard receiver clevis and cotter pins
- Red powder-coat finish
- Weighs approximately 45 pounds for easy handling

Synthetic Rope Assemblies—sold separately

Samson Synthetic rope assemblies are for use with Thern Liberty Capstan series winches only. For additional rope assemblies, contact the factory.

Rope Diameter (in) (mm)	Rope Lengths Available
1/2 12.7	300 ft. (91.4 m.), 600 ft. (182.9 m.), 1200 ft. (365.8 m.)
5/8 15.9	300 ft. (91.4 m.), 600 ft. (182.9 m.), 1200 ft. (365.8 m.)
3/4 19.1	300 ft. (91.4 m.), 600 ft. (182.9 m.), 1200 ft. (365.8 m.)

Model 3CP1S-HM*

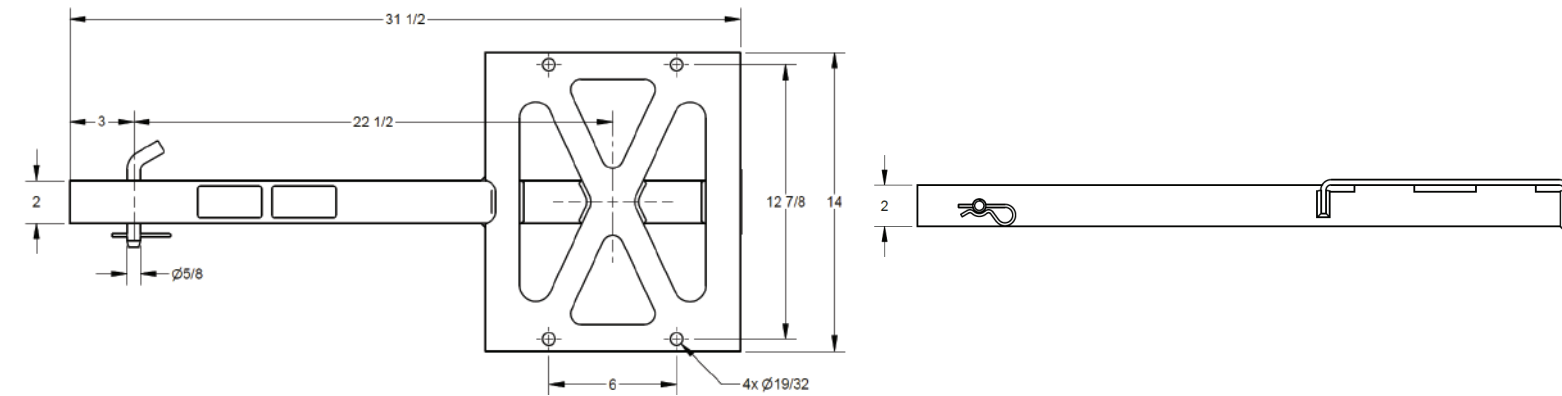

Model 3CP2S-HM*

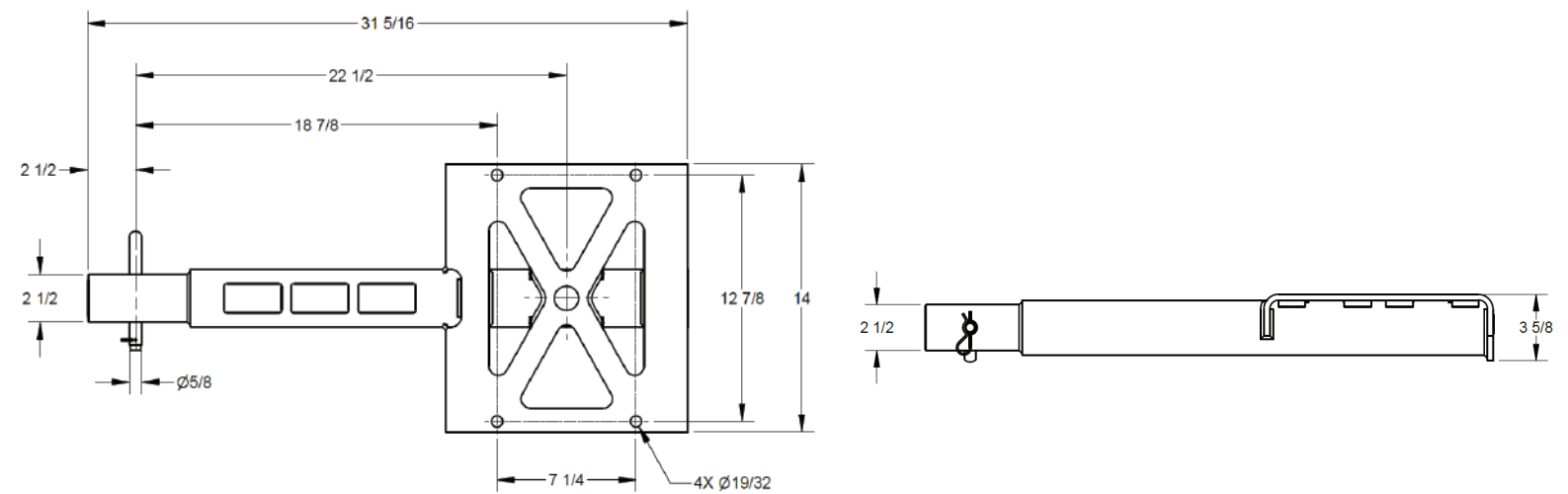

* Dimensions given in inches.



NOTICE: These products are not for lifting people or things over people.

Refer to technical pages for detailed performance information.

TECHNICAL DRAWINGS & SPECIFICATIONS
LIBERTY® SERIES
 PORTABLE CAPSTAN WINCHES

Model 3CP1M-AFS*

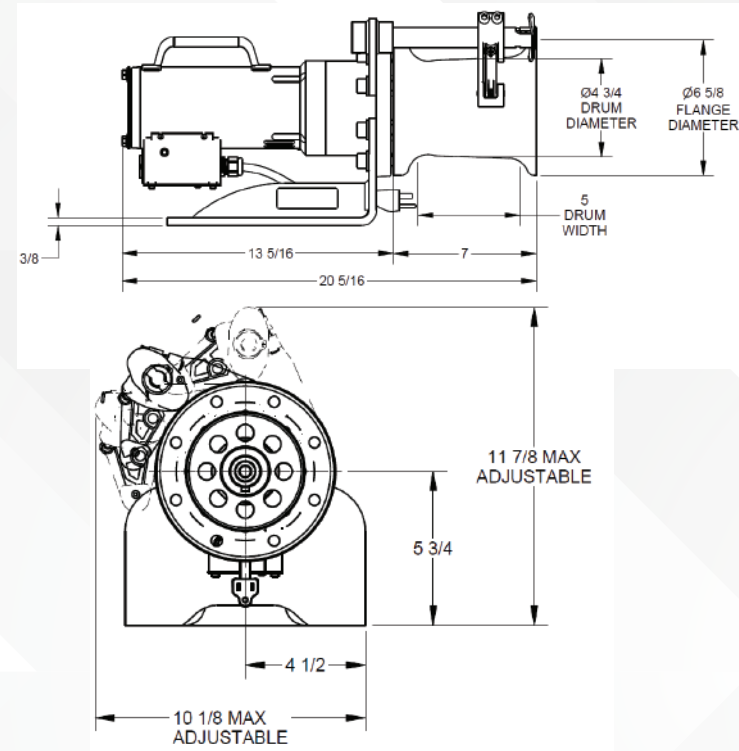
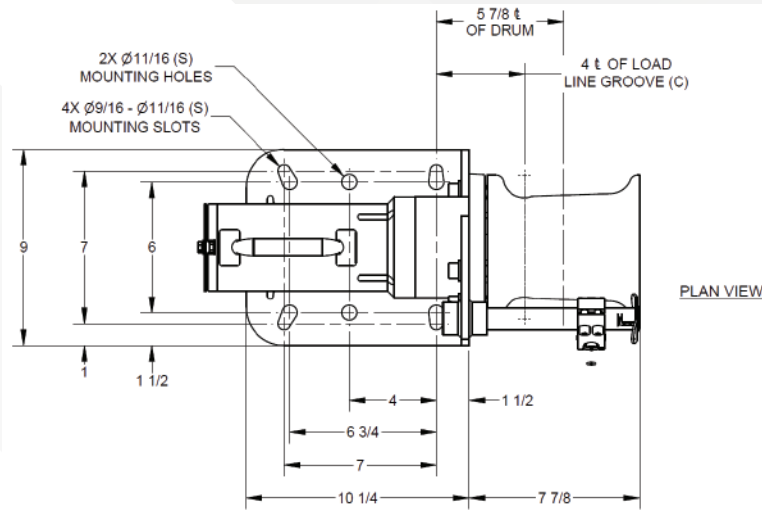

Model 3CP2S-AFS*

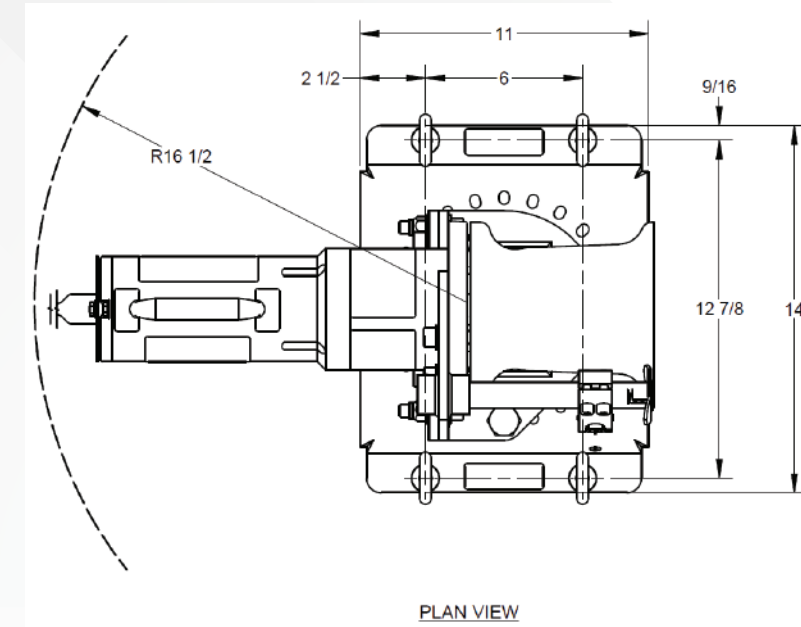

Model 3CP1S-AFS*

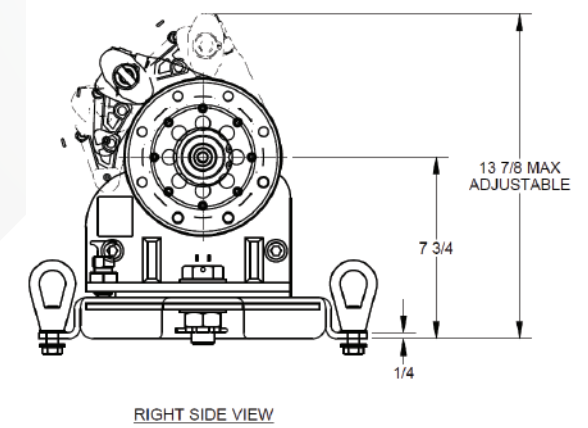
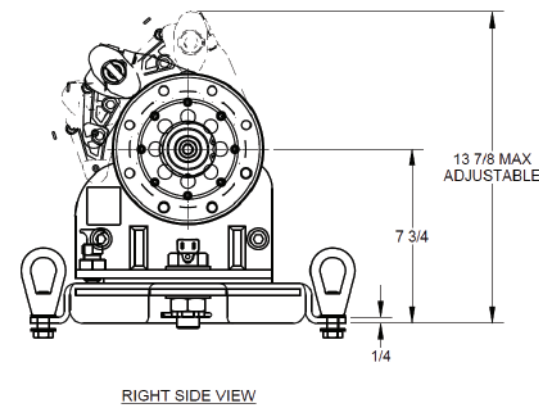
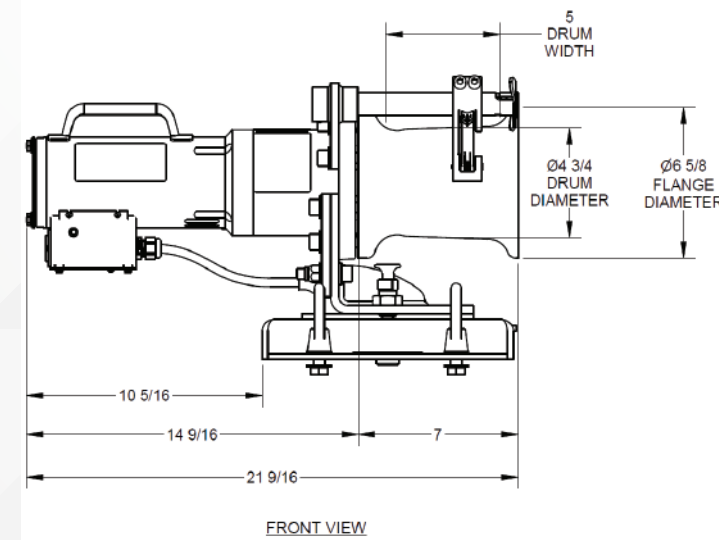
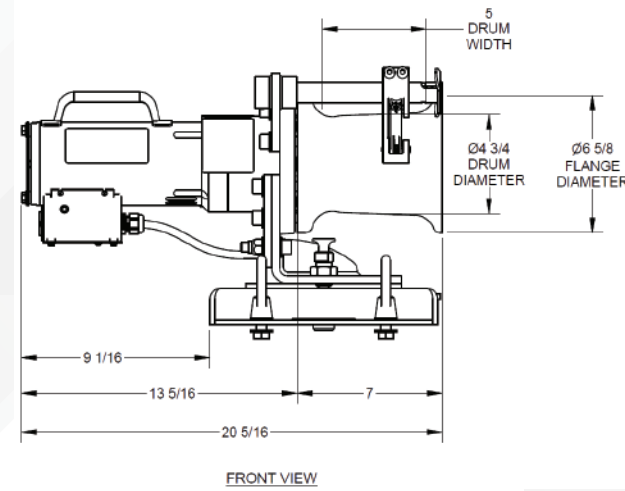
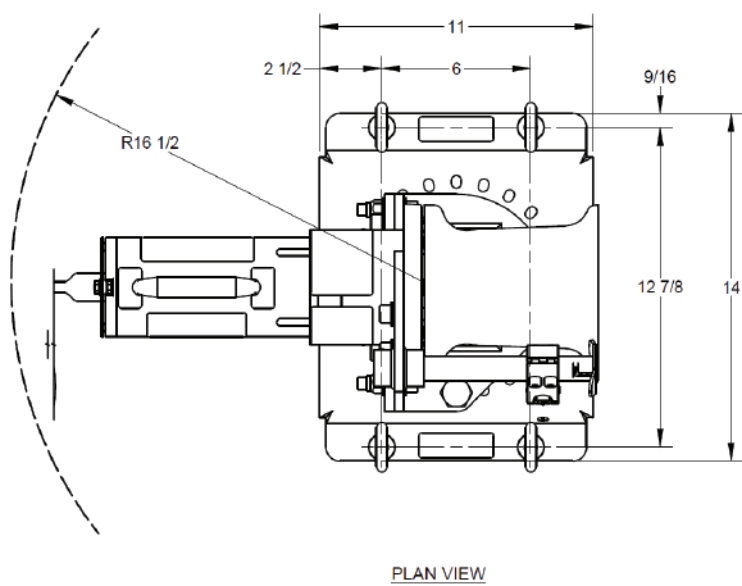

* Dimensions given in inches.



MADE IN USA 

Thern, Incorporated

World Headquarters
5712 Industrial Park Road Winona, MN USA
Toll Free: 1-800-843-7648
Phone: 1-507-454-2996
www.thern.com

Thern Europe

Amersterdam Schiphol Tetra
Siriusdreef 17-27, 2132 WT
Hoofddorp, The Netherlands
Phone: +31-546-898-380
europa@therneurope.eu