



Read this Owner's Manual thoroughly before operating the equipment. Keep it with the equipment at all times. Replacements are available from Thern, Inc., PO Box 347, Winona, MN 55987, 507-454-2996. [www.thern.com](http://www.thern.com)

**IMPORTANT:** Please record product information on page 2. This information is required when calling the factory for service.



**Big Red**

# Owner's Manual

## For TA Series Planetary Gear Air Winches

## Warranty Statement

Please record the following:

Date Purchased: \_\_\_\_\_

Model No.: \_\_\_\_\_

Serial No.: \_\_\_\_\_

This information is required when calling the factory for service.

Thern, Inc. warrants each new products to be free from defects in material and workmanship under normal use and service for a period of 24 months from the date of purchase by the original using buyer. Genuine Thern, Inc. replacement parts and components will be warranted for 30 days from the date of purchase, or the remainder of the original equipment warranty period, whichever is longer.

Under no circumstances will this warranty cover a product or component thereof, which, in the opinion of the company, has been subjected to misuse, unauthorized modifications, alteration, an accident or shipping damage. This warranty also shall not apply to products that are operated improperly, improperly maintained or improperly stored.

This warranty does not cover any costs for removal of our product, downtime, or any other incidental or consequential costs or damages resulting from the claimed defects. Brake discs, wire rope or other wear components are not covered under this warranty, as their life is subject to use conditions which vary between applications. Any alteration, repair or modification of the product outside the Thern, Inc. factory shall void this warranty.

Thern, Inc. in no way warrants pneumatic, hydraulic or electric motors and control valves or other trade accessories since these items are warranted separately by their respective manufacturers.

FACTORY AUTHORIZED REPAIR OR REPLACEMENT AS PROVIDED UNDER THIS WARRANTY IS THE EXCLUSIVE REMEDY TO THE CONSUMER. THERN, INC. SHALL NOT BE LIABLE FOR ANY INCIDENTAL OR CONSEQUENTIAL DAMAGES FOR BREACH OF ANY EXPRESS OR IMPLIED WARRANTY ON THIS PRODUCT. EXCEPT TO THE EXTENT PROHIBITED BY APPLICABLE LAW, ANY IMPLIED WARRANTY OF MERCHANTABILITY OR FITNESS FOR A PARTICULAR PURPOSE ON THIS PRODUCT IS LIMITED IN DURATION TO THE DURATION OF THIS WARRANTY.

Some states do not allow the exclusion or limitation of incidental or consequential damages, or allow limitations on how long an implied warranty lasts, so the above limitation or exclusion may not apply to you. This warranty gives you specific legal rights, and you may also have other rights which vary from state to state.

**To make a claim under this warranty, contact the factory for an RGA number. The product must be returned, prepaid, directly to Thern, Inc. or to an authorized service center. A completed warranty claim form must accompany the product. If the product is found to be defective, it will be repaired or replaced free of charge, and Thern, Inc. will reimburse the shipping costs.**

**Note: Thern, Inc. reserves the right to change the design or discontinue the production of any product without prior notice.**

## About This Manual

The Occupational Safety and Health Act of 1970 states that it is the employer's responsibility to provide a workplace free of hazard. To this end, all equipment should be installed, operated, and maintained in compliance with applicable trade, industrial, federal, state, and local regulations. It is the equipment owner's responsibility to obtain copies of these regulations and to determine the suitability of the equipment to its intended use.

This Owner's Manual, and warning labels attached to the equipment, are to serve as guidelines for hazard-free installation, operation, and maintenance. They should not be understood to prepare you for every possible situation.

The information contained in this manual is applicable only to the Thern TA Series Planetary Gear Air Winches. Do not use this manual as a source of information for any other equipment.

The following symbols are used for emphasis throughout this manual:

### **▲WARNING**

Failure to follow 'WARNING!' instructions may result in equipment damage, property damage, and/or serious personal injury.

### **▲CAUTION**

Failure to follow 'CAUTION!' instructions may result in equipment damage, property damage, and/or minor personal injury.

**Important!**

Failure to follow 'important!' instructions may result in poor performance of the equipment.

Figure 1 – Serial Tag

○		THERN, INC.		○		
		PO BOX 347				
		WINONA, MN 55987				
		(507) 454-2996				
MODEL #	<input type="text"/>					
SERIAL #	<input type="text"/>					
1ST LAYER RATING (LBS)	<input type="text"/>					
MID DRUM RATING (LBS)	<input type="text"/>					
FULL DRUM RATING (LBS)	<input type="text"/>					
1ST LAYER SPEED (FPM)	<input type="text"/>					
MID DRUM SPEED (FPM)	<input type="text"/>					
FULL DRUM SPEED (FPM)	<input type="text"/>					
DRUM SIZE (IN.)	ID	<input type="text"/>	OD	<input type="text"/>	W	<input type="text"/>
ROPE SIZE (IN.)	<input type="text"/>					
VOLTAGE	<input type="text"/>					
PRESSURE	<input type="text"/>	FLOW	<input type="text"/>			
CODE #	<input type="text"/>					
 <b>WARNING READ OWNERS MANUAL</b> NOT FOR LIFTING PEOPLE OR THINGS OVER PEOPLE						
○		PART # A5923		○		

Figure 1A - Serial Tag Location



## Suggestions for Safe Operation

### **⚠WARNING**

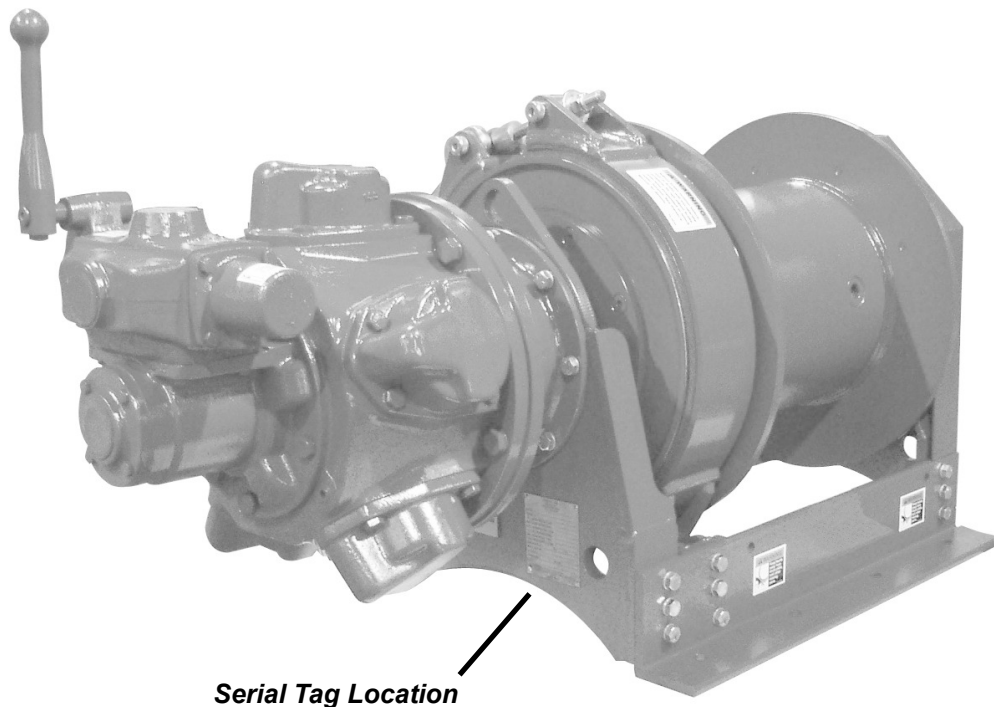
#### **DO the following:**

Read and comply with the guidelines set forth in this Owner's Manual. Keep this manual, and all labels attached to the winch, readable and with the equipment at all times. Contact Thern, Inc. for replacements.

Check lubrication before use.

Install the wire rope securely to the winch drum.

Keep at least 5 wraps of wire rope wound on the drum at all times, to serve as anchor wraps. With less than 5 wraps on the drum the wire rope could come loose, causing the load to escape.

Keep hands away from the drum, gears, wire rope, and other moving parts of the equipment.

Ensure brakes hold prior to making complete lift by lifting load a short distance and releasing control.

If there is slack wire rope condition, the hoisting mechanisms shall be inspected to ensure all wire ropes are properly seated on drums and in sheaves, before resuming winch operation.

Disconnect air supply before servicing the equipment.



---

## Suggestions for Safe Operation

**⚠WARNING****DO NOT do the following:**

**Do not lift loads over people. Do not walk or work under a load or in the line of force of any load.**

**Do not exceed the load rating of the winch or any other component in the system. To do so could result in failure of the equipment.**

**Do not use more than one winch to move a load unless each winch was designed for use in a multiple winch system.**

**Do not use damaged or malfunctioning equipment. To do so could result in failure of the equipment.**

**Do not modify the equipment in any way. To do so could cause equipment failure.**

**Do not wrap the wire rope around the load. This damages the wire rope and could cause the load to escape. Use a sling or other approved lifting device.**

**Do not operate the winch with drive guards or gear covers removed or improperly installed.**

**Do not divert your attention from the operation. Stay alert to the possibility of accidents, and try to prevent them from happening.**

**Do not jerk or swing the load. Avoid shock loads by starting and stopping the load smoothly. Shock loads overload the equipment and may cause damage.**

**Do not leave a suspended load unattended unless specific precautions have been taken to secure the load and keep people away from the winch and out from under the load.**

**Do not adjust the brake with the load suspended.**

**Do not disassemble the air cylinder for the automatic band brake, improper disassembly could cause personal injury. Contact factory.**

## 1.1 Installing the Winch

### Important!

- Inspect the winch immediately following installation according to the Instructions for Periodic Inspection. This will give you a record of the condition of the winch with which to compare future inspections.
- A qualified professional should inspect or design the foundation to insure that it will provide adequate support.
- Locate the winch so it will be visible during the entire operation.
- When moving and positioning the winch, lift using the lifting eyes in the frame or with a sling wrapped around drum.
- Do not weld the winch frame to the foundation or support structure. Welding the frame may void warranty, contact Thern, Inc. Use fasteners as instructed.

### ⚠WARNING

All supporting structure, mounting hardware and attaching hardware must be in accordance with all applicable standards codes and regulations.

Ensure proper selection and installation of wire rope and sheaves. Sheaves and sheave mounting must be designed and selected in accordance with all applicable standards, codes, and regulations. Improper installation of wire rope or sheave can cause uneven spooling and wire rope damage that could cause a load to escape.

Do not install the winch in an area defined as hazardous by the National Electric Code, unless installation in such an area has been thoroughly approved.

Do not install the winch near corrosive chemicals, flammable materials, explosives, or other elements that may damage the winch or injure the operator. Adequately protect the winch and the operator from such elements.

Position the winch so the operator can stand clear of the load, and out of the path of a broken wire rope that could snap back and cause injury.

Attach the winch to a rigid and level foundation that will support the winch and its load under all load conditions, including shock loading.

### Important!

- Use a sheave or roller guide to direct the wire rope to the drum whenever possible.
- Install sheaves, tracks and other equipment so they will remain fixed under all load conditions. Follow the recommendations of the equipment manufacturer.
- Use sheaves of proper diameter to minimize wear on the wire rope. Follow the recommendations of the sheave manufacturer.

**Figure 2 – Maintaining the Fleet Angle**

- When wire rope travels over a sheave or through a roller guide – maintain fleet angle by locating the sheave or guide an appropriate distance from the drum, shown as distance “A”.

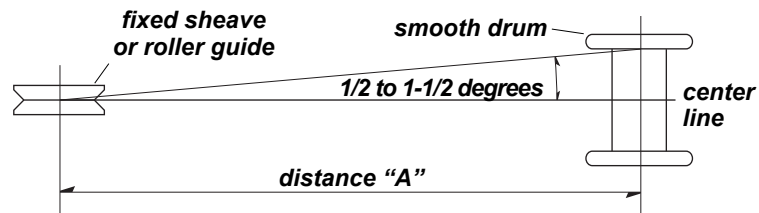

- When wire rope travels directly to the load – maintain fleet angle by controlling side-to-side movement of the load with tracks or guide rails. Allowing the load to move too far to one side causes stress on the drum flange which may cause damage.

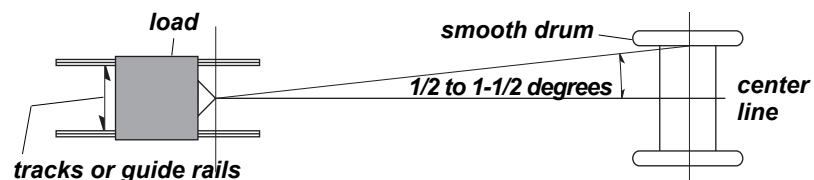

- 1.2.1 CONSULT APPLICABLE CODES AND REGULATIONS for specific rules on installing the equipment.
- 1.2.2 LOCATE THE WINCH in an area clear of traffic and other obstacles. Make sure the winch is accessible for maintenance and operation.
- 1.2.3 LOCATE THE WINCH in an area with adequate temperatures. Check the motor and reducer manufacturer's information for ambient temperature ratings.
- 1.2.4 INSTALL THE WINCH on a horizontal surface. The winch is designed and assembled for horizontal base mounting. Special consideration must be taken if mounting vertically or upside-down. Please contact Thern, Inc.
- 1.2.5 MAINTAIN A FLEET ANGLE between 1/2 and 1-1/2 degrees. The proper fleet angle minimizes wire rope damage by helping the wire rope wind uniformly onto the drum. See Figure 2.
- 1.2.6 FASTEN THE WINCH SECURELY to the foundation.
  - a FOR STANDARD PRODUCTS referred to in this manual, use coarse thread fasteners, grade 8 or better. Be sure to check the torque required for your fastener selection before mounting winch. Make sure the winch is secured to a solid foundation able to support the winch and the load under all conditions with design factors based on accepted engineering practices.
  - b NON-STANDARD PRODUCTS that vary from the original design may have different fastening requirements. Contact a structural engineer or Thern, Inc. for this information.

CONTACT A QUALIFIED PROFESSIONAL FOR MOUNTING INSTRUCTIONS TO COMPLY WITH LOCAL CODES.

## 1.3 Installing the Breather Plug

### ⚠ CAUTION

Make sure the breather plugs are clean and open to vent heat and pressure. Poor ventilation will cause overheating and result in damage to oil seals and other equipment. See Figures 3a and 3b.

For shipment, the winch motor, disc brake and reducer are filled with lubricant and motor and disc brake breather plugs installed.

- 1.3.1 VERIFY THE BREATHER PLUG is installed on the motor and disc brake. Refer to the motor and brake manufacturer's information. The reducer is not equipped with a breather plug.
- 1.3.2 CHECK THE LUBRICANT LEVEL in the motor, brake and reducer to make sure no lubricant was lost during shipment. See section 3.2 - Lubricating the Winch.

**Figure 3a – Installing the Breather Plug(s) - TA2**

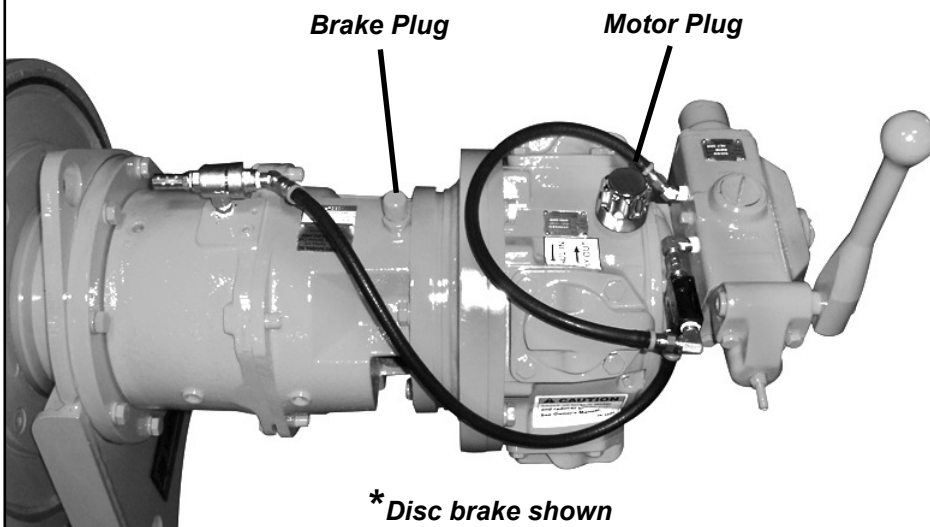

**Figure 3b – Installing the Breather Plug(s) - TA2.5 / TA5 / TA7**

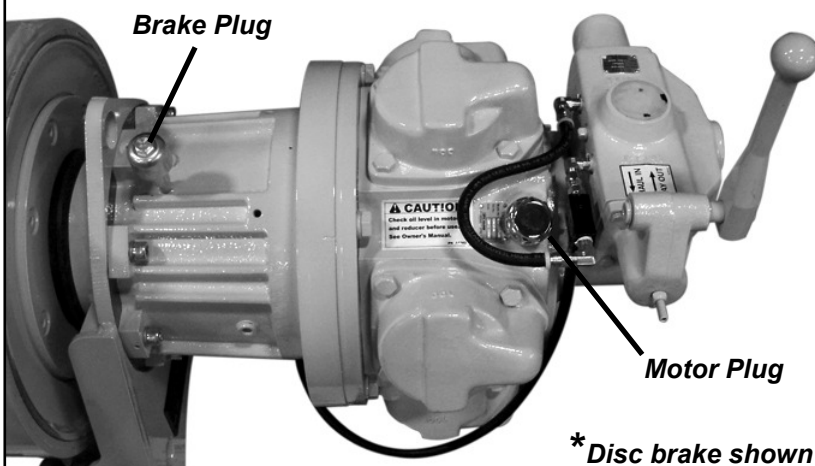



---

## 1.4 Connecting the Air Supply

**Important!**

- Use components rated for the power supply you will be using.
- Always disconnect the air supply when the winch is not in use.
- The F-R-L must be compatible with the required air supply.

**⚠WARNING**

**All control devices must be momentary type. Install all control devices so the winch motor will stop when the operator releases the device.**

**Locate control devices so the operator will be able to view the load through the entire operation.**

**Locate control devices so the operator will be clear of the load, the wire rope, and the path of a broken wire rope that could snap back and cause injury.**

**Check that the direction indicators on control match load direction.**

**Remove port caps from exhaust ports for operation. Failure to do so may result in equipment damage and limit performance. See Figure 8 on page 17.**

It is the responsibility of the owner to provide equipment for controlling the winch, The following guidelines are supplied as a reference for the installer.

**INSTALL A F-R-L ON YOUR UNIT BEFORE WINCH OPERATION. A FILTER-REGULATOR-LUBRICATOR UNIT MUST BE USED WHILE OPERATING EQUIPMENT TO MAINTAIN WARRANTY. THERN WILL NOT COVER ANY DAMAGE TO EQUIPMENT CAUSED BY DIRTY, POOR, CONTAMINATED OR NON-LUBRICATED AIR SUPPLY. SEE FIGURE 5.**

- 1.4.1 CONSULT APPLICABLE CODES AND REGULATION for specific instructions regarding power supply installation and backup.
- 1.4.2 CHECK THE COMPONENT MANUFACTURER'S INSTRUCTIONS for installing and connecting the motor, brake and other equipment.
- 1.4.3 ENSURE an accessible shut off valve has been installed in the air supply line and make sure others are aware of its location.
- 1.4.4 THE AIR SUPPLY must be clean and free from moisture.
  - a ALL AIR SUPPLY LINES should be purged with clean, moisture free air or nitrogen before connecting to winch inlet.
  - b SUPPLY LINES should be as short and straight as installation conditions will permit. Long transmission lines and excessive use of fittings, elbows, tees, globe valves etc. cause a reduction in pressure due to restrictions and surface friction in the lines.
- 1.4.5 ALWAYS USE an air line lubricator with these motors.
  - a THE LUBRICATOR must have an inlet and outlet at least as large as the inlet on the motor. Install the air line lubricator as close to the air inlet on the motor as possible.
  - b LUBRICATOR must be located no more than 10 ft. (3 m) from the motor.
  - c AIR LINE LUBRICATOR should be replenished daily and set to provide 6 to 9 drops per minute of SAE 10W oil. A fine mist will be exhausted from the throttle control valve when the air line lubricator is functioning properly.

**Figure 4 – Mufflers**

*Muffler installed in  
valve exhaust port*

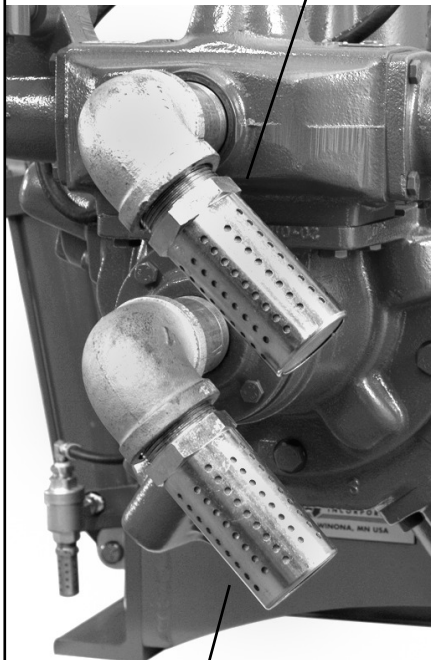

*Muffler installed in  
motor exhaust port*

- 1.4.6 IT IS RECOMMENDED that an air line strainer/filter be installed as close as practical to the motor air inlet port, but before the lubricator, to prevent dirt from entering the motor. The strainer/filter should provide 20 micron filtration and include a moisture trap. Clean the strainer/filter periodically to maintain its operating efficiency.
- 1.4.7 MOISTURE THAT REACHES THE AIR MOTOR through air supply lines is a primary factor in determining the length of time between service overhauls.
- a MOISTURE TRAPS can help to eliminate moisture.
  - b AIR RECEIVERS collect moisture before it reaches the motor.
  - c INSTALLING AN AFTERCOOLER at the compressor that cools the air to condense and collect moisture prior to distribution through the supply lines is also helpful.
- 1.4.8 THE AIR MOTOR SHOULD BE INSTALLED as near as possible to the compressor or air receiver. Recommended pressures and volumes are measured at the point of entry to the air motor.
- 1.4.9 INSTALL MUFFLERS in both exhaust ports to reduce noise. For operation, remove port caps from exhaust ports. See Figure 4.
- 1.4.10 CHECK THE AIR PRESSURE at the motor and make sure it agrees with the pressure rating marked on the winch nameplate.
- 1.4.11 TEST AIR CONNECTIONS by operating the winch.
- a ROTATION OF THE DRUM must agree with the labels on the control device, either UP and DOWN, or FORWARD and REVERSE.
  - b CHECK THE AUTOMATIC LOAD BRAKE(S), make sure it releases when the motor is ON, and engages when the motor is OFF.

CONTACT THE FACTORY OR A QUALIFIED PROFESSIONAL FOR HELP.

**Figure 5 – Filter-Regulator-Lubricator Unit (F-R-L)**

*PSI gauge installed on regulated  
lubricator side*

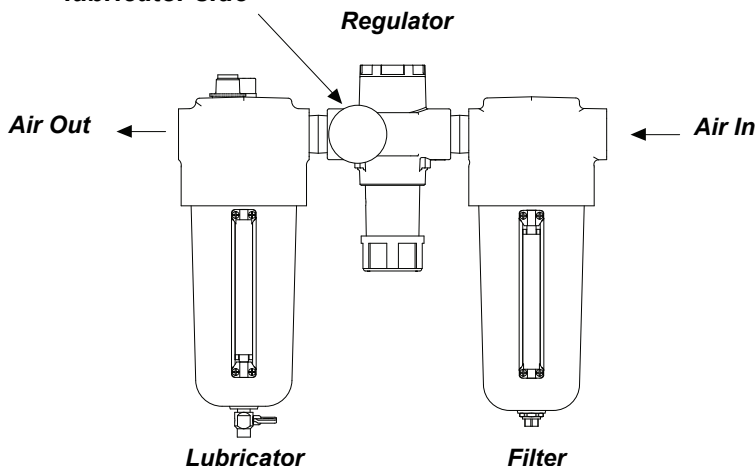

## 1.5 Installing the Wire Rope

### Important!

- Use wire rope and other rigging equipment rated for the size of the largest load you will be moving.
- Do not drag the wire rope through dirt or debris that could cause damage, or poor operation.
- Always wear protective clothing when handling wire rope.

### ⚠WARNING

**Install the wire rope securely to the winch drum. A poorly secured wire rope could come loose from its anchor and allow the load to escape.**

- 1.5.1 DETERMINE WHICH DIRECTION the drum must rotate to wind and unwind wire rope.
- 1.5.2 PURCHASE THE PROPER WIRE ROPE for your application. Keep the following in mind when selecting a wire rope. Contact a reputable wire rope supplier for help.
  - a BREAKING STRENGTH of new wire rope should be at least 3 times greater than the largest load placed on the winch. If loads are lifted or pulled on an incline, the breaking strength must be at least 5 times greater than the largest load. These are minimum values and will vary with the type of load and how you are moving it.
  - b WIRE ROPE LAY must agree with the winding direction of the drum to help insure proper winding.
  - c WE RECOMMEND 6 x 37 IWRC improved plow steel (IPS) or extra improved plow steel (EIPS) wire rope.
- 1.5.3 ANCHOR THE WIRE ROPE to the drum using the flange anchor. See Figure 6.
  - a PASS THE WIRE ROPE over the drum from the front and through the slot in the drum flange.
  - b PASS THE WIRE ROPE through the hole in the anchor block. Make sure at least 1/2 inch of wire rope extends past the set screw, and the end of the wire rope does not protrude out where it will hit other components as the drum is turning.
  - c TIGHTEN THE SETSCREW in the anchor block to securely hold the wire rope in place.
- 1.5.4 WIND FIVE FULL WRAPS of wire rope onto the drum by operating the winch while holding the wire rope taught. These wraps serve as anchor wraps and must remain on the drum at all times.

**Figure 6 – Installing the Wire Rope**

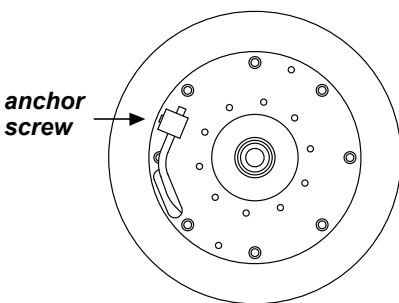

**correct**  
pass wire rope through slot  
in flange and into anchor

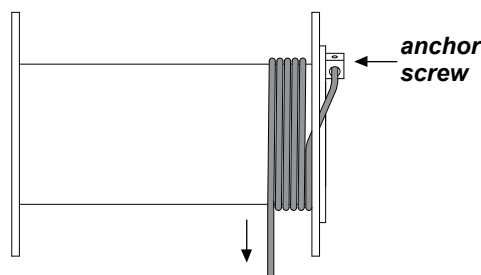

**correct**  
typical installation shown  
right lay – overwound

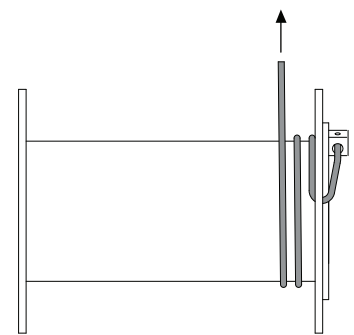

**incorrect**

## 2.1 General Theory of Operation

### Important!

- Limit nonuniform winding by keeping tension on the wire rope and by maintaining the proper fleet angle.
- To help insure rated performance, make sure the air pressure at the motor is equal to the motor's pressure rating.
- It is your responsibility to detect and account for different factors affecting the condition and performance of the equipment.
- When determining whether the load will exceed the load rating, consider the total force required to move the load.

- 2.1.1 THE PULL REQUIRED to move the load must not exceed the load rating of the winch. Consider the total force required to move the load, not the weight of the load.
- 2.1.2 THIS EQUIPMENT CAN develop forces that will exceed the load rating. It is the responsibility of the equipment user to limit the size of the load. Inspect the equipment regularly for damage according to the instructions contained in this manual and in the component manufacturer's information.
- 2.1.3 USE A LOAD BRAKE on all winches used to lift loads or drag loads on an incline. Brakes are of two basic types, band brake and disc brake. The band brake can be either manually or automatically engaged and the disc brake is automatically engaged. When engaged, they lock the drive train to the winch frame, thereby stopping drum rotation when the control is released or placed in the neutral position.
- a WHEN OPERATING REMOTELY with only a manual band brake, an operator must be present at winch for manual operation of band brake.
- 2.1.4 PERFORMANCE RATINGS of the equipment are affected by the amount of wire rope wound on the drum, the way in which it is wound, air power supply, and the way the winch is used.
- a DRUM CAPACITY depends on how tightly and evenly the wire rope is wound on the drum. Actual drum capacities are usually 25-30% less than values shown in performance tables, due to loose winding and overlapping.
- b LINE SPEED increases with each additional layer of wire rope wound onto the drum. Line speed will also vary with load weight and air power supply.
- c LOAD RATING represents the maximum pull that can be placed on new equipment. Load ratings are assigned values for specific amounts of load travel or wire rope accumulation. The load rating decreases as layers of wire rope accumulate on the drum.
- 2.1.5 DUTY RATINGS refer to the type of use the equipment is subject to. Consider the following when determining duty rating.
- a ENVIRONMENT: harsh environments include hot, cold, dirty, wet, corrosive, or explosive surroundings. Protect the equipment from harsh environments when possible.
- b MAINTENANCE: poor maintenance, meaning poor cleaning, lubrication, or inspection, leads to poor operation and possible damage of the equipment. Minimize poor maintenance by carefully following the instructions contained in this manual.
- c LOADING: severe loading includes shock loading and moving loads that exceed the load rating of the equipment. Avoid shock loads, and do not exceed the load rating of the equipment.
- d FREQUENCY OF OPERATION: frequent start and stop functions increase wear and shorten the life span of the gear train and load brake components. Lengthy operations cause lubrication to become hot, which also decreases the life span of the gear train and brakes. Increase maintenance of the equipment if used in frequent operations.

CONTACT FACTORY FOR MORE INFORMATION.

## 2.2 Inspecting/Adjusting the Brakes

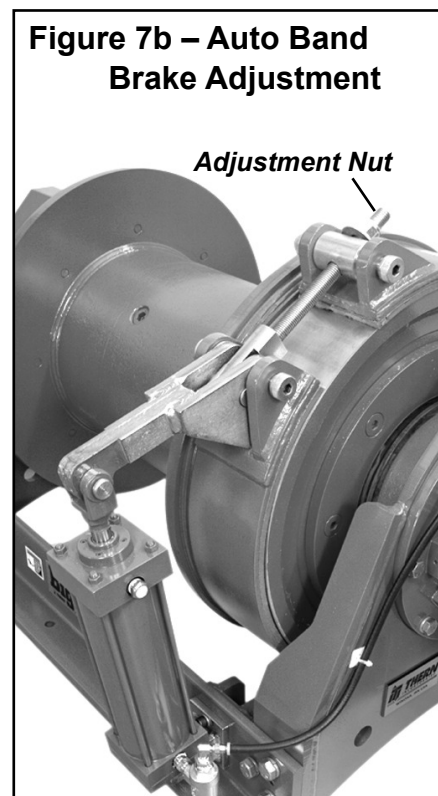
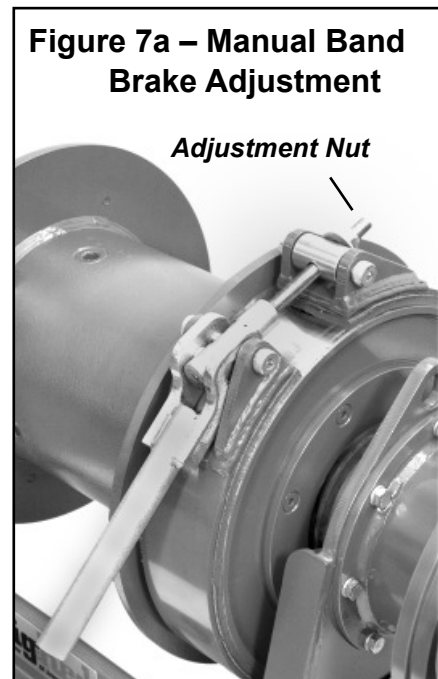

### **⚠WARNING**

**Do not adjust brakes with the winch holding a load. Accidental release of the brake could allow the load to escape.**

**Keep hands away from the drum, gears, wire rope and other moving parts of the equipment.**

**Do not disassemble the air cylinder for the automatic band brake, improper disassembly could cause personal injury. Contact factory.**

#### 2.2.1 INSPECTING THE BAND BRAKE

- a DRUM BAND BRAKE should be inspected for oil, grease and glazing. These occurrences are not uncommon but need to be fixed before operation continues. If the brake lining is oil-soaked, replace the brake bands as a set. A fine grit emery cloth should be used to sand any glazed area to remove them.
- b MEASURE BAND THICKNESS to maintain brake effectiveness. The set of brake bands must be replaced if they measure less than .125 inch thickness anywhere on the band.

2.2.2 INDIVIDUALLY TEST BRAKES installed to ensure proper operation. Brakes must hold a 125% rated load with full drum without slipping. If indicated by poor operation or visual damage, contact factory and have brake(s) repaired. Check all brake surfaces for wear, deformation or foreign deposits.

#### 2.2.3 ADJUSTING THE MANUAL BRAKE

- a MAKE SURE THERE IS NO LOAD on the winch.
- b RELEASE WIRE ROPE TENSION on the drum.
- c RELEASE TENSION OF BRAKE BANDS by disengaging the brake band handle.
- d ROTATING THE ADJUSTMENT NUT clockwise will tighten the brake band. Adjustments should be made in increments of 1/2 rotation. See Figure 7a.
- e CHECK THE ADJUSTMENT by engaging the band brake. The brake is properly adjusted when it can be pushed into the lock position (with the handle over center) with 50 to 100 lbs of force being applied to the handle and holding the rated load for that model winch. If not, repeat step "d" until correct.

#### 2.2.4 ADJUSTING THE AUTOMATIC BAND BRAKE

- a MAKE SURE THERE IS NO LOAD on the winch.
- b RELEASE WIRE ROPE TENSION on the drum.
- c RELEASE TENSION ON BRAKE BANDS by applying air to the brake cylinder.
- d ROTATE THE ADJUSTMENT NUT clockwise will tighten the brake band. Adjustments should be made in increments of 1/2 rotation. See Figure 7b.
- e CHECK THE ADJUSTMENT by engaging the band brake. The brake is properly adjusted when it holds the rated load for that model winch. If not, repeat step "d" until correct.

2.2.5 AUTOMATIC DISC BRAKE ADJUSTMENT is not required. If the disc brake does not hold the rated load contact the factory for repair instructions.

---

## 2.3 Breaking-In The Winch

**⚠WARNING**

**Remove exhaust port caps for operation. Failure to do so may result in equipment damage and limit performance. See Figure 8.**

- 2.3.1 BEFORE THE WINCH IS PLACED INTO SERVICE or for winches that have been in storage for a period of more than one month, the following start-up procedure is required. See Figure 8.
- a INSPECT THE WINCH and other equipment according the Instructions for Periodic Inspection.
  - b WHEN FIRST OPERATING THE WINCH it is recommended that the motor be driven slowly in both directions for a few minutes.
  - c ENSURE BRAKES HOLD prior to making complete lift by lifting load a short distance and releasing control.
- 2.3.2 PRIOR TO INITIAL USE, all new, altered or repaired winches shall be tested to ensure proper operation. See Figure 8.
- a CHECK THAT THE OIL LEVEL in motor, reduction gear assembly and disc brake are correct.
  - b ALL NEW DRUM BRAKE BAND LININGS require a "run-in" period. Operate the winch without load in the payout direction while gradually applying the brake. Allow the brake to slip for approximately one minute. Winch motor may stall as drum brake band lining fully engages. **Do not allow brake to overheat. Check operation of brakes following run-in. See section 2.2 - Inspecting/Adjusting the Brakes**
- 2.3.3 INSPECT THE WINCH following the break-in according to the Instructions for Periodic Inspection. See section 3.3 - Inspecting the Equipment.

---

## 2.4 Preparing for Operation

**⚠WARNING**

**Read and comply with the guidelines set forth in this Owner's Manual. Keep this manual, and all labels attached to the winch, readable and with the equipment at all times. Contact Thern, Inc. for replacements.**

**Do not lift loads over people. Do not walk or work under a load or in the line of force of any load.**

**Do not exceed the load rating of the winch or any other component in the system. To do so could result in failure of the equipment.**

**The winch must be equipped with a load brake if it is used to lift loads or drag loads on an incline.**

**Do not use more than one winch to move a load unless each winch was designed for a multiple winch system.**

**Do not use damaged or malfunctioning equipment. To do so could result in failure of the equipment.**

**Do not modify the equipment in any way. To do so could cause equipment failure.**

**Do not operate the winch with guards removed or improperly installed.**

**Check lubrication before use.**

2.4.1 **CONSIDER THE OPERATION.** Do not begin until you are sure you can perform the entire operation without hazard.

a **WHEN OPERATING REMOTELY** with only a manual band brake, an operator must be present at winch for manual operation of band brake.

2.4.2 **A PRE-OPERATION MEETING** attended by the winch operator, ground crew, signalperson, persons to be lifted and the person in charge of the task to be performed shall be held to plan and review the procedure to be followed, including:

- Signals.
- Appropriate number of signal persons and ground crew.
- Designate responsibility.

a **THIS MEETING SHALL BE HELD** prior to the beginning of operations at each new work location and thereafter for any new employees assigned to the operation.

b **DURING THIS MEETING** it is recommended that a comprehensive plan to cover emergency procedures be worked out prior to exercising the winch capabilities of this winch.

2.4.3 **INSPECT ALL COMPONENTS** of the system.

a **INSPECT THE WINCH** and other equipment according to the Instructions for Frequent Inspection.

- b OPERATORS shall be physically competent and have no health condition which might affect their ability to act, and they must have good hearing. Operators who are fatigued or have exceeded their normal shift period shall check all related regulations regarding approved work periods prior to operation. Refer to training program - See section 2.3.1. The operator must thoroughly understand proper methods of rigging and attaching loads and should have a good attitude regarding safety.
  - c THE LOAD must be clear of other objects and free to move. Make sure the load will not tip, spin, roll away, or in any way move uncontrollably.
- 2.4.4 KNOW YOUR LOAD and make sure you do not exceed the load rating of the winch or any other equipment in the system.



## 2.5 Air Valve Adjustment

### **⚠WARNING**

Remove port caps from exhaust ports for operation. Failure to do so may result in equipment damage and limit performance. See Figure 8.

Make sure to check the adjustment of the air valve flow restrictor screw if winch operating speeds differ from performance specifications during lowering or pay out of wire rope.

Do not adjust the flow restrictor while suspending or hoisting a load.

#### 2.5.1 ADJUSTMENT FOR LIFTING APPLICATIONS - SEE FIGURE 8

**NOTE:** This adjustment setting is only a recommendation for initial startup in order to prevent over speeding while lowering. The actual adjustment required is dependent on the load and the specific unit purchased.

- a LOOSEN NUT AND ADJUST SCREW located in the valve end cap.
- b ADJUST UNTIL DRUM SPEED for full load pay-out is equal to or less than the drum speed for no-load haul-in.
- c TIGHTEN THE NUT when drum speed is adjusted.

#### 2.5.2 ADJUSTMENT FOR PULLING APPLICATIONS - SEE FIGURE 8

- a LOOSEN NUT AND ADJUST SCREW located in the valve cap end.
- b ADJUST UNTIL DRUM SPEED for no-load payout equals the drum speed for no-load haul in.
- c TIGHTEN NUT when drum speed is adjusted.

**Figure 8 – Motor and Valve**

NOTE: Thern recommends installing mufflers in exhaust ports to reduce noise. For operation remove port caps from exhaust ports.

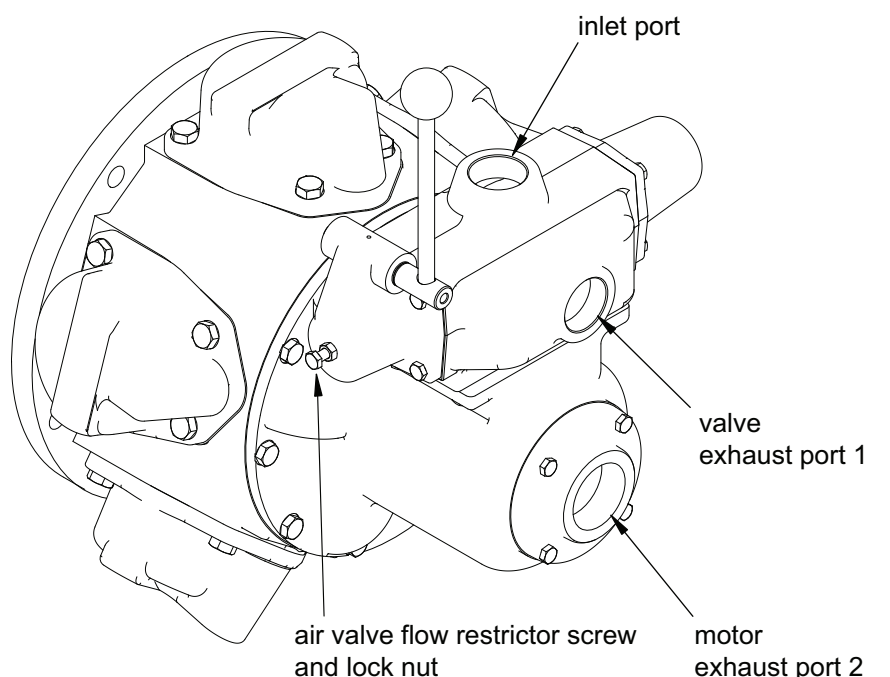

---

## 2.6 Attaching the Load

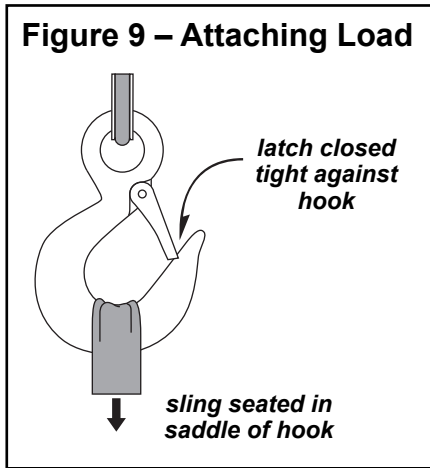
**⚠WARNING**

**Do not wrap the wire rope around the load. This damages the wire rope and could cause the load to escape. Use a sling or other approved lifting device.**

- 2.6.1 CLEAR OBJECTS from the path of the load so you can move it freely and observe it at all times during the operation.
- 2.6.2 ATTACH THE LOAD using a nylon sling, or other approved lifting device. Follow the recommendations of the sling manufacturer.
  - a SEAT THE SLING in the saddle of the hook with the hook latch completely closed. See Figure 9. Always make sure the load is properly seated in the saddle of the hook. Do not tiplload the hook as this may allow the load to slip out of engagement and leads to spreading and eventual failure of the hook.
  - b CENTER THE LOAD on the hook so it will remain balanced and not tip or rotate to one side.

## 2.7 Moving the Load

### Important!

- Obey a stop signal from anyone.
- Maintain tension on the wire rope to keep it tightly and evenly wound on the drum.
- If the winch and load are not visible during the entire operation, get help from another person.
- Appoint a supervisor if more than one person is involved in the operation. This will reduce confusion and increase safety.
- When lifting a load, use a tag line to keep the load from swinging or twisting, while keeping yourself away from the load.
- Lifting and lowering speeds shall be operator-controlled and be as slow as practical.
- The winch operator shall remain at the controls at all times.

### **⚠WARNING**

**Keep at least 5 wraps of wire rope wound on the drum at all times, to serve as anchor wraps. With less than 5 wraps on the drum the wire rope could come loose, causing the load to escape.**

**Keep all unnecessary personnel away from the winch. Keep out of the path of the load, and out of the path of a broken wire rope that might snap back and cause injury.**

**Keep hands away from the drum, gears, wire rope, and other moving parts of the equipment.**

**Winches must use controls that spring return to neutral and stop all motion when released. Various controls are available with the winches and are dependent on air supply, location to winch and degree of control required.**

**Operators must maintain visual or audio contact with personnel and the load at all times. Operators must remain at the controls at all times.**

**Monitor surrounding conditions to prevent the load from contacting hazardous obstructions.**

**Use spotters or signal person to assist with positioning the load in confined or limited visibility areas.**

**Do not divert your attention from the operation. Stay alert to the possibility of accidents, and try to prevent them from happening.**

**Do not jerk or swing the load. Avoid shock loads by starting and stopping the load smoothly. Shock loads overload the equipment and may cause damage.**

**Do not leave a suspended load unattended unless specific precautions have been taken to secure the load and keep people away from the winch and out from under the load. Remain at the controls when the personnel platform is occupied.**

2.7.1 **MOVE THE LOAD** slowly and smoothly, only a small distance at first. Make sure the load is balanced and securely attached before continuing.

#### **Before operating, the following conditions shall exist:**

- a WIRE ROPE shall be free of kinks.
- b MULTIPLE PART LINES shall not be twisted around each other.
- c THE PRIMARY POINT of wire rope attachment shall be centered over the load so that the load will not tilt and remain level.
- d IF THERE IS SLACK wire rope condition, the hoisting mechanisms shall be inspected to ensure all wire ropes are properly seated on drums and in sheaves, before resuming winch operation.

2.7.2 **USE THE CONTROL DEVICE** to operate the winch. The control device must be momentary type, so the winch will stop when the operator releases the control. See Figure 10.

- 2.7.3 THE MANUAL BAND BRAKE is engaged by pushing down on the handle and disengaged by pulling up. If the handle is pushed down fully, it should lock in that position and prevent drum rotation, until disengaged by the operator. The brake must be kept properly adjusted to hold the required load. See Figure 11.
- 2.7.4 THE AUTOMATIC BAND BRAKE is engaged and disengaged by the cylinder. When engaged it should lock in that position and prevent drum rotation, until disengaged by the operator. The brake must be kept properly adjusted to hold the required load.
- 2.7.5 THE AUTOMATIC DISC BRAKE is a spring applied, air released brake. The brake automatically disengages when the motor is operated. When the control valve is placed in the neutral position, the brake automatically engages preventing drum rotation.
- 2.7.6 OBSERVE THE WIRE ROPE as it winds onto the drum. If it becomes loose, uneven, or overlapped, stop the operation and rewind the wire rope before continuing. Continued operation with overlapped or uneven wire rope can damage the wire rope and shorten its life.
- 2.7.7 OBSERVE THE REDUCER, MOTOR AND BRAKE during operation for signs of overheating. Frequent overheating may be a sign of damage, or may indicate the need for a larger power winch.
- a WATCH FOR SMOKE, the smell of burnt lubricant, and other signs of overheating. Use a thermocouple or other device to monitor reducer temperature.
  - b STOP THE OPERATION if the reducer, motor or brake overheats, and allow the winch to cool. Continued operation may cause damage.
- 2.7.8 IN CASE OF AIR SUPPLY FAILURE, shut off the air supply line valve and DISCONNECT the air supply line from the winch. Leave the air supply DISCONNECTED. See section 2.8 - Emergency Operation.

## 2.8 Emergency Operation

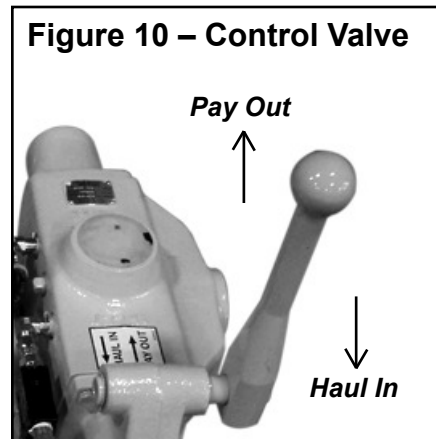

### **⚠WARNING**

Emergency lowering operations must be performed by a minimum of two personnel trained in the operation of the winch.

Communication must be established between personnel and the winch operator. The operator should be able to visually monitor the load through its full range of travel.

2.8.1 EMERGENCY OPERATION PROCEDURE for air winch with manual band brake.

- a THE MANUAL BAND BRAKE is engaged by pushing down the handle and disengaged by pulling up. If the handle is pushed down fully, it should lock in that position and prevent drum rotation, until disengaged by the operator. The brake must be kept properly adjusted to hold the required load. See Figure 11.

b STEPS FOR EMERGENCY LOWERING:

- Engage the manual band brake to hold the load.
- In case of air supply failure, turn the control device to off and disconnect the air supply. Leave the air supply disconnected.
- Supply a secondary source of air to the inlet port of the control valve.
- By operating the control valve and the manual band brake, gradually disengage the band brake to slowly lower the load.
- Remove the load from the load line.

2.8.2 EMERGENCY OPERATION PROCEDURE for air winch with two automatic brakes.

- a THE AUTOMATIC BAND BRAKE is engaged by energizing the cylinder and disengaged by releasing the energized air pressure to the cylinder. When engaged it should lock in that position and prevent drum rotation, until disengaged by the operator.
- b THE BRAKE must be kept properly adjusted to hold the required load. The automatic disc is a spring applied, air released brake. The brake automatically disengages when the motor is operated. When the control valve is placed in the neutral position, the brake automatically engages preventing drum rotation.

c STEPS FOR EMERGENCY LOWERING:

- Engage the automatic band brake to hold the load,
- In case of air supply failure, turn the control device to off and disconnect the air supply. Leave the air supply disconnected.
- Supply a secondary source of air to the inlet port of the control valve.
- By operating the control valve, gradually disengage the band brake to slowly lower the load.
- Remove the load from the load line.

2.8.3 ALTERNATIVE SECONDARY AIR SUPPLY CONNECTION

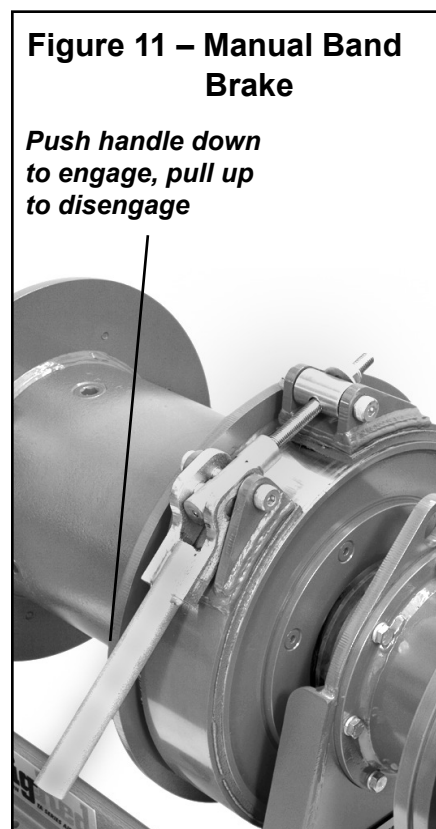

- a DISENGAGE THE AUTOMATIC DISC BRAKE AND AUTOMATIC BAND BRAKE (if equipped) by attaching an air supply and pressurizing the brake(s), causing the load to lower.
- b IN THE AIR SUPPLY LINES install a valve capable of releasing the air pressure. This valve will allow the operator to release air pressure, causing the brake(s) to engage and the load to stop. In this manner the operator can slow or stop the lowering of the load.
- c STEPS FOR EMERGENCY LOWERING:
  - Engage the band brake to hold the load.
  - In case of air supply failure, turn the control device to off and disconnect the air supply. Leave the air supply disconnected.
  - Supply a secondary source of air to the inlet port of the disc brake and automatic band brake (if equipped). **Do not pressurize until ready to lower the load.**
  - Install a valve capable of releasing the air pressure to actuate the brake(s).
  - With air pressure supplied to the brake(s), control line speed with the band brake. If equipped with an automatic band brake, control line speed using the installed valve to regulate air pressure supplied to the brake(s).
  - Remove the load from the load line.

#### 2.8.4 ALTERNATIVE SECONDARY BACK UP AIR SUPPLY

- a Connect the back up air supply to the inlet.
- b Operate the control valve to pay out the winch until the load is lowered.

ANY QUESTIONS ON OPERATION OR WINCH APPLICATION CALL  
THERN, INC.

### 3.1 Cleaning the Winch

#### Important!

Increase the frequency of maintenance procedures if the winch is:

- Operated for long periods.
- Used to pull heavy loads.
- Operated in wet, dirty, hot or cold surroundings.

Clean the winch to remove dirt and help prevent rust and corrosion.

- 3.1.1 CLEAN THE WINCH every six months or whenever it is dirty. Wipe down all equipment to remove dirt and grease.
- 3.1.2 REMOVE ALL UNNECESSARY OBJECTS from the area around the winch.

### 3.2 Lubricating the Winch

#### Important!

- Do not leave plug holes in the reducer or motor open. Open plug holes will allow dirt and moisture to contaminate the lubrication.
- Make sure lubricant has a temperature rating appropriate for the ambient temperatures of the operation.
- Lubricate the winch properly to help protect it from wear and rust. Read the following instructions carefully.

#### ⚠CAUTION

**Make sure the breather plugs are clean and open to vent heat and pressure. Poor ventilation will cause overheating and result in damage to oil seals and other equipment.**

**Fill the reducer, disc brake and motor to the proper level without overfilling. Too much or too little lubricant will cause overheating and result in damage to equipment.**

For shipment, the winch motor, disc brake and reducer are filled with lubricant and motor breather and disc brake plug(s) installed.

- 3.2.1 LUBRICATE THE REDUCER, DISC BRAKE AND MOTOR according to the manufacturer's instructions.
  - a FILL THE REDUCER, DISC BRAKE AND MOTOR with oil before operating the winch. Fill the reducer, disc brake and motor until oil reaches the level check plug. **Do not mix different lubricants.** See Tables 1 & 2.
  - b CHECK OIL LEVEL before every operation and every 10 hours during operation. Remove the level plug and make sure oil is even with the plug hole. See Figure 13.
  - c CHANGE REDUCER, DISC BRAKE AND MOTOR LUBRICANT at least every 2 years, or whenever it is dirty or contaminated. See Figures 12A and 12B.
  - d THE REDUCER is not equipped with a breather plug.
- 3.2.2 LUBRICATE THE WIRE ROPE by following the wire rope manufacturer's recommendations.
- 3.2.3 IF WINCH IS DISASSEMBLED, clean all parts thoroughly and coat bearings and seals with clean grease. Use sufficient grease to provide a good protective coat.
- 3.2.4 OIL DRAIN/FILL PROCESS
  - a LOCATE 2 OF THE LARGE PIPE PLUGS in the sides of the drum located at approximately 90 degrees to one another. These are access plugs to the reducer drain and fill plugs. (Dependent on the model there may be two or three pipe plugs in the drum.)
  - b REMOVE THE FIRST OF THE ACCESS PLUGS from the drum. See Figure 13 - Lubricating the Winch.

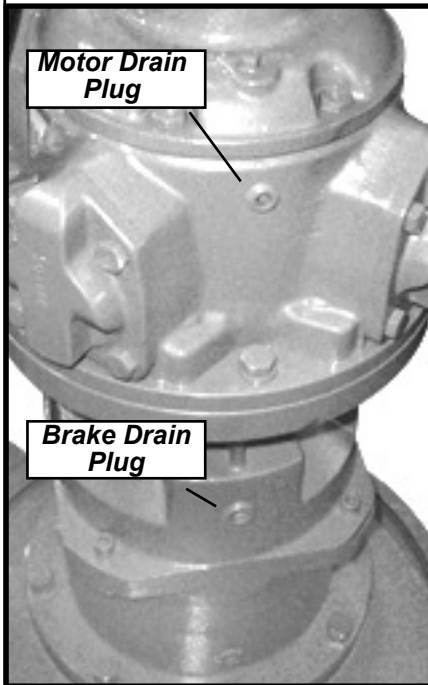
**Figure 12A - TA2 Series**

- c LOOK INTO THE NOW OPENED ACCESS PLUG HOLE. You will find another pipe plug which is in the reducer. Remove it. (This will become the drain hole.)
- d ROTATE THE DRUM so that the open access plug hole is down at the 6 o'clock position and a second access plug is located approximately 90 degrees from it on the side of the drum.
- e REMOVE THE ACCESS PLUG in the side of the drum.
- f LOOK INTO THE OPENED ACCESS PLUG HOLE in the side of the drum and you will find another pipe plug which is in the reducer. Remove it. (Removing this plug will speed up the drain process and will become the fill hole.)
- g ALLOW THE OIL TO COMPLETELY DRAIN.
- h ROTATE THE DRUM so that one hole is at the 3 o'clock or the 9 o'clock position and the other is approximately at the 12 o'clock position. The hole in the 12 o'clock position will now become the fill hole and the hole on the side of the drum will become the level hole. (The 12 o'clock position may vary per model.)
- i FILL THE REDUCER with oil until the oil shows at the reducer level hole in the side of the drum.
- j INSERT THE OIL LEVEL REDUCER PLUG into the reducer and tighten and then install the access plug into the drum.
- k FINISH BY INSTALLING THE REDUCER FILL PLUG into the reducer and install the access plug into the drum.

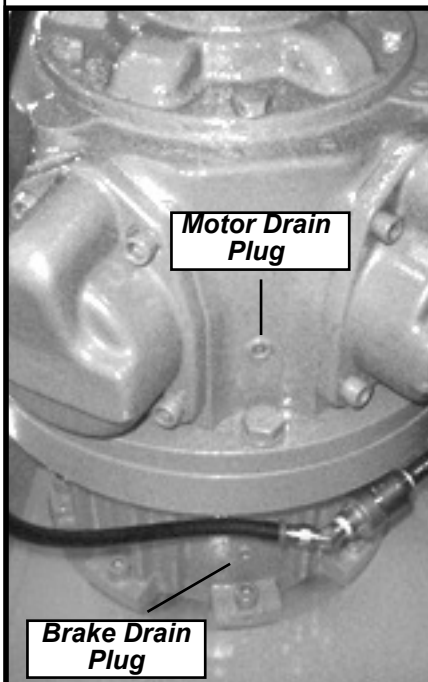
**Figure 12B - TA2.5 - 7 Series**



**Figure 13 – Lubricating the Winch**

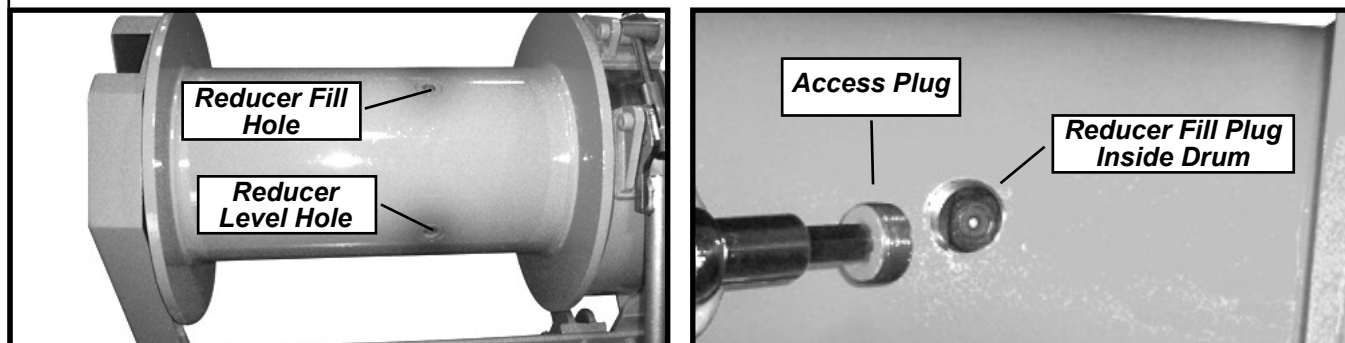

**Table 1 – Motor and Reducer Lubrication Table**

SERIES	OIL TYPE OR EQUIVALENT	MOTOR (FL OZ)	REDUCER (FL OZ)
TA2 SERIES	MOBIL SHC 630	13	55
TA2.5 SERIES	MOBIL SHC 630	38	84
TA5 SERIES	MOBIL SHC 630	38	122
TA7 SERIES	MOBIL SHC 630	38	199

**Table 2 – Disc Brake Lubrication Table**

SERIES	OIL TYPE OR EQUIVALENT	DISC BRAKE (FL OZ)
TA2 SERIES	MOBIL 424	76
TA2.5 SERIES	MOBIL 424	110
TA5 SERIES	MOBIL 424	110
TA7 SERIES	MOBIL 424	110

## 3.3 Inspecting the Equipment

### Important!

- Start an inspection program as soon as you put the winch into use.
- Appoint a qualified person to be responsible for regularly inspecting the equipment.
- Keep written records of inspection. This allows comparison with comments from previous inspections so you can see changes in condition or performance.
- Make sure all labels and plates are readable, firmly attached, free of damage and clean. Replacements are available from the factory.

### Perform frequent inspections:

- Before each operation.
- Every 3 hours during operation.
- Whenever you notice signs of damage or poor operation.

### Perform periodic inspections:

- Every 6 months except for as noted below.
- Whenever there is noticeable damage, loose fasteners, or poor operation during frequent inspection.
- Whenever you return the winch to service from storage.
- Whenever the winch has, or may have been, overloaded or shock loaded.
- Internal or inaccessible fasteners have been designed such that inspection is only required every 2 years.

### **⚠WARNING**

**Do not use damaged or malfunctioning equipment. Place an “OUT OF ORDER” sign on the winch. Do not use the winch until the sign is removed by a qualified maintenance person who has completely corrected the problem.**

Inspect the winch to detect signs of damage or poor operation before they become hazardous. See Table 3 - Inspection Checklist.

- 3.3.1 CONSULT APPLICABLE CODES AND REGULATIONS for specific rules on inspecting the winch and other equipment.
- 3.3.2 CHECK COMPONENT MANUFACTURER’S INSTRUCTIONS for inspecting the motor, brake, reducer, bearings, wire rope, and other equipment.

### 3.3.3 Instructions for Frequent Inspection

- a VISUALLY INSPECT the entire winch and all other equipment involved in the operation.
- Check all equipment for cracks, dents, bending, rust, wear, corrosion and other damage.
  - Make sure the wire rope is installed correctly and anchored securely to the drum.
  - Check the reducer, motor and disc brake for signs of leakage.
  - Make sure the entire winch is properly lubricated.
  - Make sure the motor and disc brake breather plugs are clean, open, and installed correctly.
  - Make sure mounting fasteners are tightened securely.
  - Make sure the foundation is in good condition, and capable of supporting the winch and its load under all load conditions.
  - Check air supply and connections for wear, corrosion, cuts, and other damage.
- b TEST WINCH PERFORMANCE by operating the winch with a load not exceeding the load rating.
- Listen for unusual noises, and look for signs of damage as you operate the winch.
  - Make sure the wire rope winds evenly and tightly onto the drum. If it is loose or uneven, rewind it before continuing.
  - Make sure the load moves smoothly, without hesitation or strain.
  - Make sure the winch responds to the control device. It must rotate as shown on the control labels, and it must turn off when you release the control.
  - Check the brake(s). Raise the load, then lower it and stop it a few feet off the ground. If the load continues to coast or creep under normal operating conditions, the brake(s) needs adjustment. See section 2.2 - Inspecting/ Adjusting the Brakes.

**Completely correct all problems before continuing. Use the Troubleshooting Chart to help determine the cause of certain problems. See Table 4.**

## Frequent Wire Rope Inspection:

- Use ASME B30.7 as a guideline for rope inspection, replacement and maintenance.
- Check the wire rope, end connections and end fittings for corrosion, kinking, bending, crushing, bird-caging or other signs of damage.
- Check the number, distribution and type of visible broken wires. See paragraph 3.3.4 c and Figure 14.
- Check the wire rope for reduction of rope diameter from loss of core support, or wear of outside wires. See Figure 15.
- Take extra care when inspecting sections of rapid deterioration such as sections in contact with saddles, sheaves, repetitive pickup points, crossover points and end connections.

Figure 14 – Broken Wires

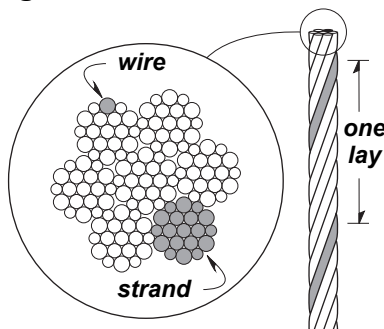

**Wire rope assembly must be replaced if more than 6 wires are broken in one lay, or if more than 3 wires are broken in one strand in one lay.**

## 3.3.4 Instructions for Periodic Inspection, See Table 3.

- VISUALLY INSPECT** the winch and all other equipment.
  - Disassembly may be required in order to properly inspect individual components. Contact factory for assembly/disassembly instructions. Disassembly before contacting Thern, Inc. voids all warranties.
  - Check the finish for wear, flaking, or other damage.
  - Check all equipment for cracks, dents, bending, rust, wear, corrosion and other damage. If the equipment was overloaded, or if you notice cracks and other signs of overloading and damage, promptly remove equipment from use and have it repaired or replaced. **DO NOT CONTINUE TO USE DAMAGED OR OVERLOADED EQUIPMENT OR WIRE ROPE.**
  - Check all fasteners for stripped threads, wear, bends, and other damage.
  - Check all fasteners for proper torque levels. Some fasteners will require disassembly of the winch in order to inspect and retorque. **NOTE: those fasteners inside the drum (i.e. reducer fasteners) need to be checked every 2 years. Contact Thern, Inc. for instructions on Assembly and Disassembly. See Table 5.**
  - Check the reducer, motor and disc brake for signs of leakage.
  - Make sure the motor breather plug is clean, open and installed correctly.
  - Make sure all labels and plates are readable, firmly attached, free of damage and clean. Replacements are available from the factory.
- DRAIN A SMALL AMOUNT OF LUBRICANT** from the reducer, motor and disc brake into a clean container.
  - Check the lubricant for dirt, metal particles, water, and other signs of contamination. Completely drain the reducer and motor if lubricant is contaminated.
  - Make sure the winch is completely lubricated. See section 3.2 - Lubricating the winch.
- INSPECT THE WIRE ROPE** according to the wire rope manufacturer's recommendations, or follow accepted industry standards for wire rope inspection.
  - Always wear protective clothing when handling wire rope.
  - Check the entire length of wire rope for bent wires, crushed areas, broken or cut wires, corrosion, and other damage. Carefully inspect areas that pass over sheaves or through roller guides.
  - Note the location and concentration of broken wires. Replace wire rope if more than 6 wires are broken in one lay, or more than 3 wires are broken in one strand in one lay. See Figure 14.
  - Make sure the load hook or other device is securely attached to the wire rope, and the wire rope where it is attached is not frayed, corroded, broken, or otherwise damaged.
  - Measure the throat opening, thickness, and twist of the hook. Replace the hook if it shows signs of damage. See Figure 16.
  - Make sure hook latch opens without binding and closes when released.
  - Check the anchor holes in the drum and the surrounding area for signs of wear or distortion.

**Figure 15 – Rope Diameter**

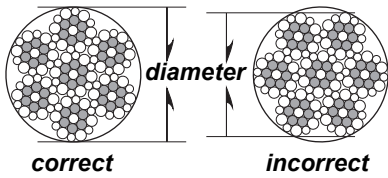

**The wire rope assembly must be replaced if the diameter measures less than the minimum diameter at any point.**

nominal wire rope diameter	maximum allowable reduction from nominal diameter
up to 5/16 in	1/64 in (.0156 in)
up to 1/2 in	1/32 in (.0313 in)
up to 3/4 in	3/64 in (.0469 in)
up to 1-1/8 in	1/16 in (.0625 in)
up to 1-1/2 in	3/32 in (.0938 in)

**Figure 16 – Load Hook Inspection**

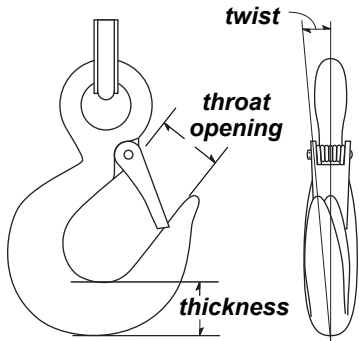

**The wire rope assembly must be replaced if the throat opening is 15% wider than nominal, if the thickness is 10% less than nominal, or if the hook is twisted 10° or more.**

- d MOVE THE DRUM with your hands. Check for excessive movement indicating worn or loose gears or bearings. Excessive movement is caused by overloading or overheating, and is a sign that your application may require a larger power winch. Disassemble the winch if necessary. Inspect gears, keys, bearings, seals, and shafts for wear, distortion, and other damage.
- e PLACE enough weight to keep the wire rope straight and tightly drawn.
  - Measure the diameter of the wire rope, especially in areas where wear is noticeable. Replace the wire rope if the diameter measures below the minimum diameter at any point. See Figure 15.
- f INSPECT THE FOUNDATION AND RIGGING.
  - Check mounting fasteners for stripped threads, wear, and other damage.
  - Check the foundation for cracks, corrosion, and other damage.
- g TEST WINCH PERFORMANCE by operating the winch with a load equal to the load rating.
  - Listen for unusual noises, and look for signs of damage as you operate the winch.
  - Make sure the wire rope winds evenly and tightly onto the drum. If it is loose or uneven, rewind it before continuing.
  - Observe the rotating drum, look for signs of loose or misaligned bearings.
  - Make sure the winch responds to the control device. It must rotate as shown on the control labels, and it must turn off when you release the control.
  - Make sure the load moves smoothly without hesitation or strain.
  - Check the brake(s). Raise the load, then lower it and stop it a few feet off the ground. If the load continues to coast or creep under normal operating conditions, the brake(s) needs adjustment. See section 2.2 - Inspecting/ Adjusting the Brakes.
- h DISCONNECT AIR SUPPLY and inspect equipment.
  - Check air supply and connections for wear, corrosion, cuts and other damage.
- i CONNECT AIR SUPPLY.

**Completely correct all problems before continuing. Use the troubleshooting chart to help determine the cause of certain problems. See table 4.**



**Table 4 – Troubleshooting Chart**

Contact the factory for assembly/disassembly instructions. Disassembly before contacting Thern, Inc. voids all warranties.

<b>problem</b>	<b>cause</b>	<b>correction</b>
<b>motor won't run</b>	<ul style="list-style-type: none"> <li>• no air supply to winch . . . . .</li> <li>• load too heavy. . . . .</li> <li>• motor damaged. . . . .</li> </ul>	<ul style="list-style-type: none"> <li>.check air supply line connections and hoses</li> <li>.lighten load</li> <li>.repair or replace as necessary</li> </ul>
<b>winch runs slow</b>	<ul style="list-style-type: none"> <li>• improper hose or fitting size</li> <li>• load too heavy . . . . .</li> <li>• motor may be damaged . . . . .</li> <li>• bearing seized up . . . . .</li> <li>• exhaust ports restricted. . . . .</li> </ul>	<ul style="list-style-type: none"> <li>check fittings, connections for size and length. Replace parts that may restrict air flow. Inspect air line filter. Make sure both exhaust ports are not restricted.</li> <li>.lighten load</li> <li>.inspect and replace as necessary</li> <li>.inspect and replace as necessary</li> <li>.remove cap and install mufflers</li> </ul>
<b>motor runs, drum doesn't turn</b>	<ul style="list-style-type: none"> <li>• loose or broken gear keys or splines . . . . .</li> <li>• loose, stripped or broken gears . . . . .</li> </ul>	<ul style="list-style-type: none"> <li>.inspect and replace as necessary</li> <li>.inspect and replace as necessary</li> </ul>
<b>motor tries to turn but can't</b>	<ul style="list-style-type: none"> <li>• unit overheated . . . . .</li> <li>• load too heavy. . . . .</li> <li>• motor may be damaged . . . . .</li> <li>• insufficient air supply. . . . .</li> <li>• brake may not be released . . . . .</li> <li>• gears or bearings broken or locked . . . . .</li> </ul>	<ul style="list-style-type: none"> <li>.allow to cool</li> <li>.lighten load</li> <li>.inspect and repair as necessary</li> <li>.verify air supply pressure and volume at winch inlet meet the requirements listed</li> <li>.inspect and repair as necessary</li> <li>.inspect and replace as necessary</li> </ul>
<b>air lines freeze</b>	<ul style="list-style-type: none"> <li>• water in air supply</li> </ul>	<ul style="list-style-type: none"> <li>install or drain air system moisture traps, moisture collecting air receivers and compressor aftercoolers. After corrective actions have been taken, disconnect lines at winch inlet and purge with clean, dry air or nitrogen prior to attaching load and operating winch.</li> </ul>
<b>brake does not operate properly</b>	<ul style="list-style-type: none"> <li>• brake release lever in release position . . . . .</li> <li>• low air supply pressure on disc brake</li> <li>• brake adjusted incorrectly . . . . .</li> <li>• brake worn or damaged . . . . .</li> <li>• brake components seized up or damaged . . . . .</li> <li>• load too heavy. . . . .</li> </ul>	<ul style="list-style-type: none"> <li>.move to lock position</li> <li>ensure air pressure at the inlet to disc brake is 50 psi</li> <li>.inspect and adjust brake</li> <li>.inspect and replace as necessary</li> <li>.inspect and repair as necessary</li> <li>.lighten load</li> </ul>
<b>lubricant leakage</b>	<ul style="list-style-type: none"> <li>• worn bearings . . . . .</li> <li>• damaged oil seals or gaskets . . . . .</li> <li>• cracked or damaged reducer or motor . . . . .</li> </ul>	<ul style="list-style-type: none"> <li>.inspect and replace as necessary</li> <li>.inspect and replace as necessary</li> <li>.inspect and repair as necessary</li> </ul>
<b>excessive end play on drive shaft</b>	<ul style="list-style-type: none"> <li>• loose or damaged keys, keyways or splines . . . . .</li> <li>• excessively worn gears. . . . .</li> </ul>	<ul style="list-style-type: none"> <li>.inspect and replace as necessary</li> <li>.inspect and repair as necessary</li> </ul>
<b>excessively worn gears or bearings</b>	<ul style="list-style-type: none"> <li>• load too heavy. . . . .</li> <li>• poor lubrication of reducer or bearings . . . . .</li> </ul>	<ul style="list-style-type: none"> <li>.lighten load</li> <li>.inspect and lubricate as necessary</li> </ul>



## 3.4 Repairing the Winch

### Important!

- It is your responsibility to determine when to replace parts. When considering whether to continue using a part or to replace it, remember that replacing it is the best way to avoid further equipment damage.
- Replace spring pins, retaining rings, and oil seals whenever the winch is disassembled for inspection or repair.
- Appoint a qualified person to be responsible for all repairs to the equipment.
- Turn off air system and depressurize air lines before performing any maintenance.

- 3.4.1 GET FACTORY AUTHORIZATION for all repairs. Unauthorized repairs will void the warranty, and may lead to damage or failure of the winch.
- 3.4.2 REPLACE DAMAGED OR POORLY OPERATING PARTS with Thern repair parts.
- 3.4.3 CLEAN THE DRUM BRAKE BAND using a wire brush or emery cloth. Do not wash the drum brake band in liquid. If the drum brake band lining is oil soaked, it must be replaced.
- a INSPECT THE DRUM BAND BRAKE LINING for oil, grease and glazing. If the drum band brake lining is oil-soaked replace the brake bands as a set. Remove glazed areas of band brake lining by sanding lightly with a fine grit emery cloth.
  - b MEASURE THE THICKNESS OF THE DRUM BAND BRAKE LINING. If the drum brake band linings are less than .125 inch thick anywhere along the edges replace the brake bands as a set.
- 3.4.4 REFINISH AREAS where the paint is worn or flaking. A good finish helps to protect against corrosion and weather damage.
- a REMOVE THE FINISH from damaged areas, down to the bare metal.
  - b CLEAN THE AREA thoroughly.
  - c REPAINT with a high quality primer and finishing coat.
- 3.4.5 TO ORDER REPAIR PARTS, contact your local dealer. Include the following information when ordering:
- model number (**See Figure 1**)
  - **serial number** (or code number) (**See Figure 1**)
  - part number
  - date purchased, and from whom
  - description of what happened, or what is wrong
  - your name and return address



---

## 4.1 Transporting the Winch

**Important!**

- Keep a record of what you ship and when you send it.



- 4.1.1 REMOVE THE BREATHER PLUG and install a sealed plug to prevent the loss of lubrication during shipment.
- 4.1.2 PACK THE WINCH in an upright position for transport, using the original packaging materials, if possible.
  - a FASTEN THE WINCH to a wooden base using bolts, to keep it from moving during transport.
  - b SEAL THE WINCH in plastic with a desiccant to help protect it from rust, corrosion, and other damage.
  - c CONSTRUCT WOODEN SIDES and top to enclose the winch in a solid protective crate.
  - d PACK LOOSE PARTS in small boxes or ship separately.
- 4.1.3 INSPECT THE WINCH according to the Instructions for Periodic Inspection before installing it in a new location.

---

## 4.2 Storing the Winch

- 4.2.1 FILL THE REDUCER, DISC BRAKE AND MOTOR with lubricant, and make sure the breather plugs are clean and properly installed. Add a rust preventative for long term storage. Follow the reducer and motor manufacturer's instructions.
- 4.2.2 SEAL THE WINCH in plastic with a desiccant to help protect it from rust, corrosion, and other damage.
- 4.2.3 STORE THE WINCH upright, in a cool clean place away from corrosive chemicals and moisture.
- 4.2.4 ROTATE THE DRUM PERIODICALLY to keep bearing and gears surfaces from becoming lacquered. Release the brake to rotate the drum.
- 4.2.5 INSPECT THE WINCH according to the Instructions for Periodic Inspection before installing it for operation.
- 4.2.6 DRAIN THE REDUCER, DISC BRAKE AND MOTOR and fill with proper lubricant prior to operation.

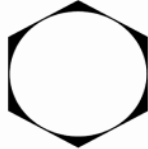
**Table 5 - Suggested Bolt Torque**

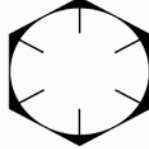
SIZE	SAE GRADE 2 		SAE GRADE 5 		SAE GRADE 8 	
	DRY	LUBRICATED	DRY	LUBRICATED	DRY	LUBRICATED
1/4 - 20	5.5	4.1	8	6.3	12	9
1/4 - 28	6.3	4.7	10	7.2	14	10
5/16 - 18	11	8	17	13	25	18
5/16 - 24	12	9	19	14	27	20
3/8 - 16	20	15	31	23	44	33
3/8 - 24	23	17	35	26	50	37
7/16 - 14	32	24	50	37	70	50
7/16 - 20	36	27	55	41	75	55
1/2 - 13	50	37	75	55	105	80
1/2 - 20	55	41	85	65	120	90
9/16 - 12	70	50	110	80	150	115
9/16 - 18	75	60	120	90	170	125
5/8 - 11	95	70	150	110	210	160
5/8 - 18	110	80	170	125	240	180
3/4 - 10	170	130	260	200	370	280
3/4 - 16	190	145	300	220	420	310
7/8 - 9	170	125	430	320	600	450
7/8 - 14	180	135	470	350	670	500
1 - 8	250	190	640	480	910	680
1 - 12	270	200	700	530	990	740
1 1/8 - 7	350	260	790	590	1290	960
1 1/8 - 12	400	300	890	670	1440	1080
1 1/4 - 7	500	370	1120	840	1820	1360
1 1/4 - 12	550	410	1240	930	2010	1510
1 3/8 - 6	650	490	1470	1100	2380	1780
1 3/8 - 12	740	560	1670	1250	2710	2030
1 1/2 - 6	870	650	1950	1460	3160	2370
1 1/2 - 12	980	730	2190	1640	3560	2670

NOTE: M16-2 X 260MM FOR TA7 REDUCER ARE TORQUED TO 269 FT-LBS.

- \* THIS CHART OF ESTIMATED TORQUE VALUES IS OFFERED ONLY AS GUIDE. CONDITIONS WILL VARY.
- \* TORQUE VALUES ARE GIVEN IN FOOT POUNDS (FT-LBS), MULTIPLY BY 12 FOR INCH POUNDS (IN-LBS).
- \* REFERENCE LUBRICATED VALUES WITH LIQUID THREAD LOCK, OILS, OR OTHER LUBRICANTS.
- \* REFERENCE 'GRADE 2' VALUES WHEN USED IN ALUMINUM OR OTHER SOFT METALS.
- \* TORQUE = COEFFICIENT x NOMINAL DIAMETER x CLAMP LOAD
- \* CLAMP LOADS ARE BASED ON 75% OF MINIMUM PROOF LOADS.
- \* ESTIMATED DRY COEFFICIENT = 0.20 , LUBRICATED COEFFICIENT = 0.15

FILTER-REGULATOR-LUBRICATOR (F-R-L) <sup>1</sup>		C4203	
item	description	part number	qty
1	FILTER	B4575	1
2	FITTING NIPPLE 1-1/2 NPT X 3.00 LNG GALV	A8825	2
3	REGULATOR	B4576	1
4	PRESSURE GAUGE	A7378	1
5	LUBRICATOR	B4577	1

<sup>1</sup> C4203 used on all units.

**F-R-L Assembly**

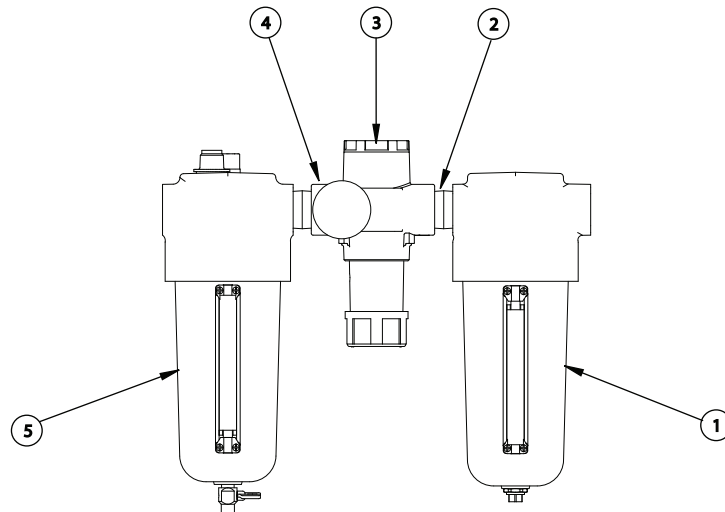

MUFFLER ASSEMBLY		C4201		C4202	
item	description	part number	qty	part number	qty
<b>TA2<sup>1</sup></b>					
1	FITTING NIPPLE 1 NPT X 3.00 LNG GALV	A8823	1	-	
1a	FITTING NIPPLE 1-1/4 NPT X 3.00 LNG GALV	A8824	1	-	
2	FITTING ELBOW 1 NPT FEMALE 90 DEG GALV	A7593	1	-	
2a	FITTING ELBOW 1-1/4 NPT FML 90 DEG GALV	A8821	1	-	
3	MUFFLER SHELL TYPE 1 NPT MALE	A7008	1	-	
3a	MUFFLER SHELL TYPE 1-1/4 NPT MALE	A8819	1	-	
<b>TA2.5 / TA5 / TA7</b>					
1	FITTING NIPPLE 1-1/2 NPT X 3.00 LNG GALV	-		A8825	2
2	FITTING ELBOW 1-1/2 NPT FEMALE 90 DEG GALV	-		A8822	2
3	MUFFLER SHELL TYPE 1-1/2 NPT MALE	-		A8820	2

<sup>1</sup> TA2 exhaust ports are 1 NPT (valve) and 1-1/4 NPT (motor "a") respectively. See Figure 8 on page 18.

**Muffler Assembly**

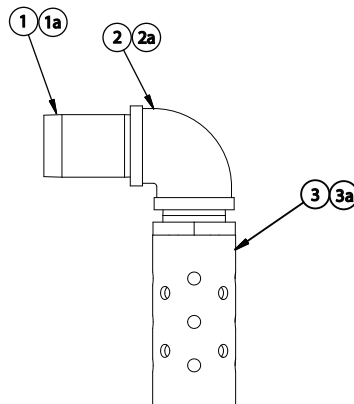

**TA2 Series Air Winch  
with disc brake**

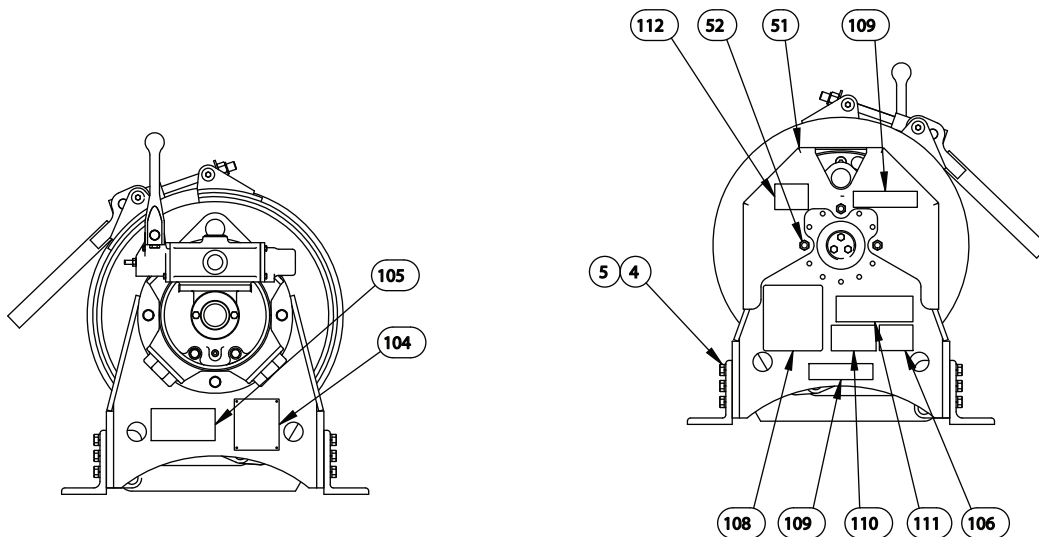
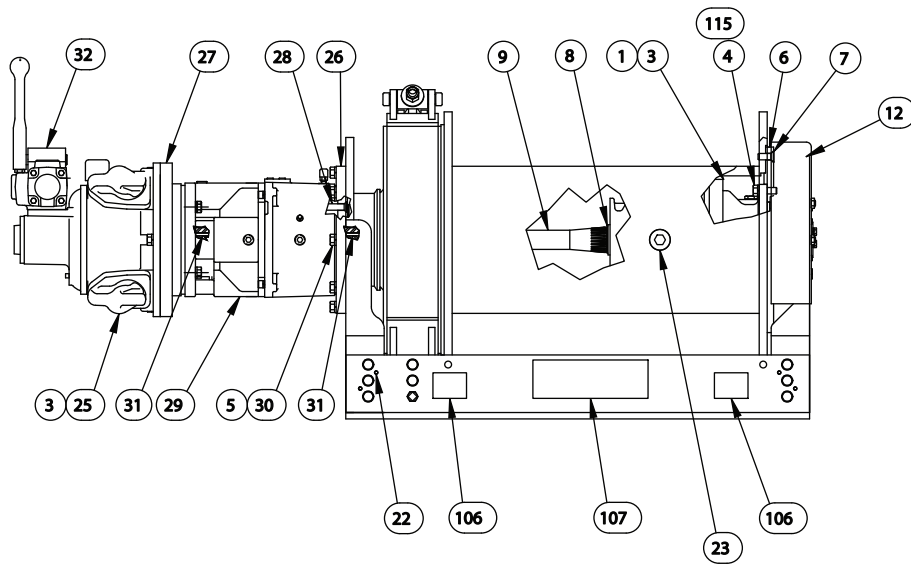
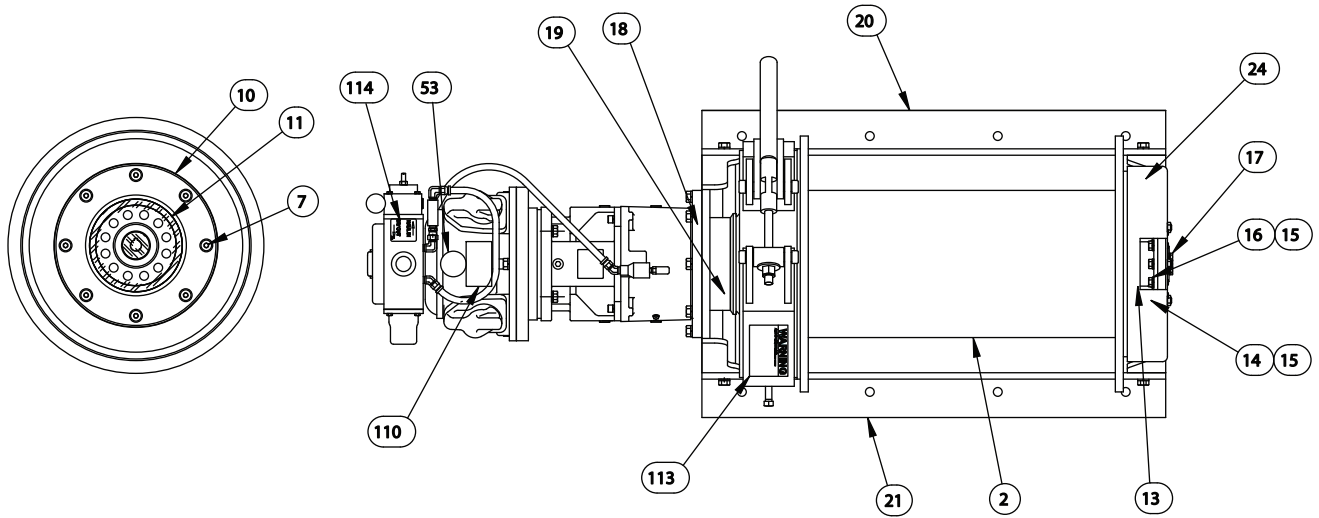

## TA2 SERIES AIR WINCH PARTS LIST

item	description	part number	qty
<b>ALL UNITS</b>			
1*	REDUCER ET3045 145.7:1 (TA2P-SERIES)	C3939	1
1*	REDUCER ET3045 73.5:1 (TA2HP-SERIES)	C4341	1
2**	DRUM MACHINING TA2-16	D2754	1
2**	DRUM MACHINING TA2-24	D2675	1
3	LUBRICANT GEAR	A6939	SEE MANUAL
4	CAPSCR HEXHD .500-13NC X 1.500 ZNPL GR5	A3134	22
5	WASHER HELSPRLK .500 X .873 X .125 ZNPL	A2930	29
6	REDUCER FLANGE	C3976	1
7	CAPSCR SOKFLTHD .500-13NC X 1.250 ZNPL	A8358	16
8	RING RETSPIRAL EXT 1.969 SPRSTL	A8297	1
9**	INPUT SHAFT ASSEMBLY TA2-16	B4758	1
9**	INPUT SHAFT ASSEMBLY TA2-24	B4759	1
10	BEARING SHAFT MACHINING	B4399	1
11	BEARING BALL	A8299	1
12	REDUCER END PLATE	D2677	1
13	SHAFT HOLDER	B4409	1
14	CAPSCR HEXHD .438-14NC X 1.500 ZNPL GR5	A2895	3
15	WASHER HELSPRLK .438 X .779 X .109 ZNPL	A3151	12
16	CAPSCR HEXHD .438-14NC X 1.250 ZNPL GR5	A4719	9
17	SHAFT COVER	A8380	1
18	MOTOR END PLATE	D2679	1
19	SEAL	A8298	1
20**	REAR FRAME ANGLE TA2-16	C4081	1
20**	REAR FRAME ANGLE TA2-24	C3979	1
21**	FRONT FRAME ANGLE TA2-16	C4082	1
21**	FRONT FRAME ANGLE TA2-24	C3980	1
22	PIN DOWEL .250 X 1.000	A8359	8
23	PLUG PIPE 1.25-11.5 NPT	A8294	2
24	SETSCR SOKHD NYLK .500-13NC X .750 ZNPL	A3713	1
25	MOTOR PISTON RM310	C3937	1
26	BRAKE MOTOR ADAPTER	B4397	1
27	MOTOR ADAPTER	B4396	1
28	CAPSCR SOKFLTHD .500-13NC X 1.750 ZNPL	A8296	4
29	BRAKE 54 FT/LB	C4146	1
30	CAPSCR HEXHD .500-13NC X 1.750 ZNPL GR5	A3164	16
31	KEY 6MM X 6MM X 40MM 4140 CD BES	A8360	2
32	VALVE MANUAL CONTROL	B4675	1
33	BRAKE MOUNTING BRACKET	B4405	2
34	BRAKE BAR	B4408	1
35	LOWER LINK PLATER	A8373	2
36	NUT HEX JAM .500-13NC ZNPL GR5	A2893	1
37	SETSCR SQHD .500-13NC X 3.500 ZNPL STL	A2892	1
38	BAND BRAKE	C3972	2
39	BRAKE ADJUSTING LINK	B4404	1
40	NUT HEX NYLK .625-11NC ZNPL GR2	A3072	1
41	WASHER FLT STDPLT .625 X 1.750 X .134 ZNPL	A3073	1
42	BRAKE ADJUSTING BLOCK	A8376	1
43	SHLDRSCR SOKHD .750 X .625 ZNPL ALYSTL	A8293	4
44	BRAKE HANDLE PIN TA2 ZNPL	A8377	1
45	SETSCR SOKHD NYLK .312-18NC X .750 SST	A2885	1
46	SHUTTLE VALVE	A8770	1
47	FITTING NIPPLE 1/4" NPT X -4 JIC	A8846	1
48	FITTING SWIVEL 1/4" NPTM X -4 JIC FEMALE	A8847	1
49	HOSE .25 ID X .50 OD PUSH ON	A8350	AS REQUIRED
50	MUFFLER SHELL 1/4" NPT	A8826	1
51	CABLE ANCHOR GUARD	C4113	1
52	NUT HEX JAM .438-14NC ZNPL	A8716	3
53	FILLER BREATHER HOODED THREADED 3/8 BSP	A9009	1
115	WASHER NORD-LOCK NL1/2" SP .53 X .77 X .10	A12228	12
<b>MANUAL CONTROL VALVE</b>			
54	VALVE HANDLE	B4558	1
55	CAPSCR HEXHD M10-1.5 X 35MM 8.8 ZNPL	A8282	1

\* Item 1 varies depending on the gear ratio.

\*\* Items 2, 9, 19 and 20 vary depending on the drum size of the winch

**TA2 Series  
Brake Plumbing**

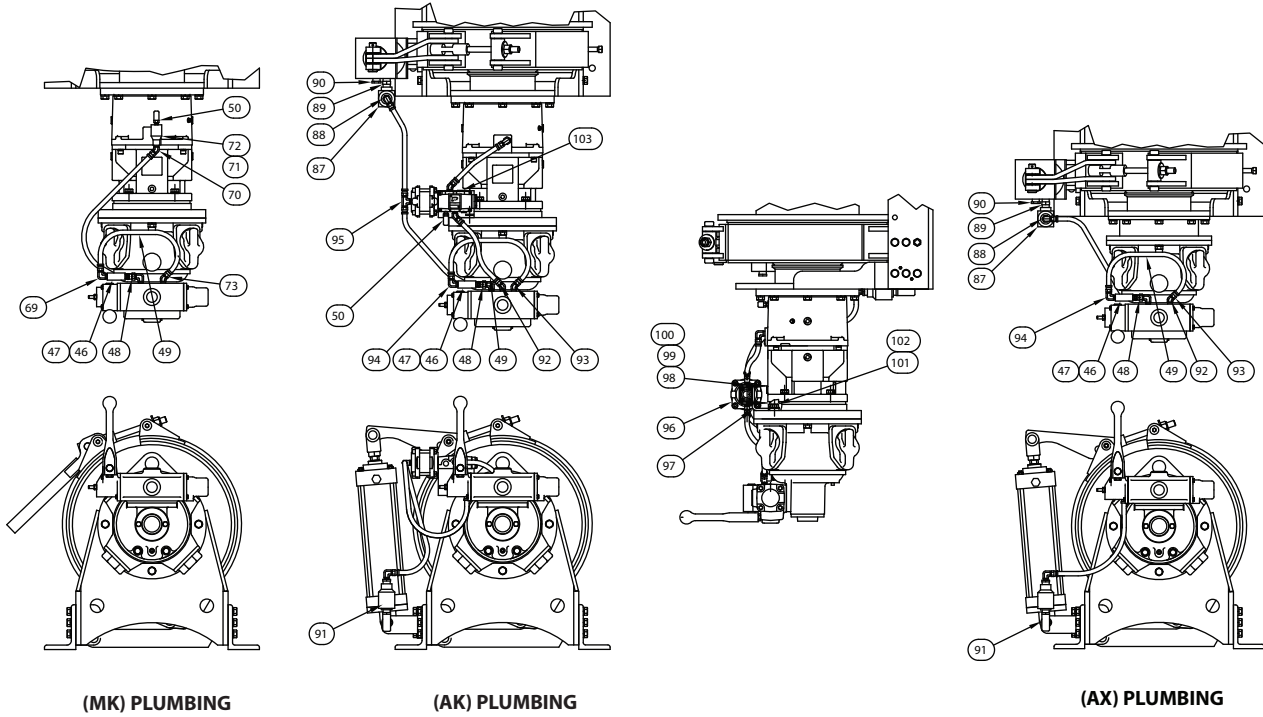

**TA2 Series  
Manual Band Brake  
and  
Automatic Band Brake**

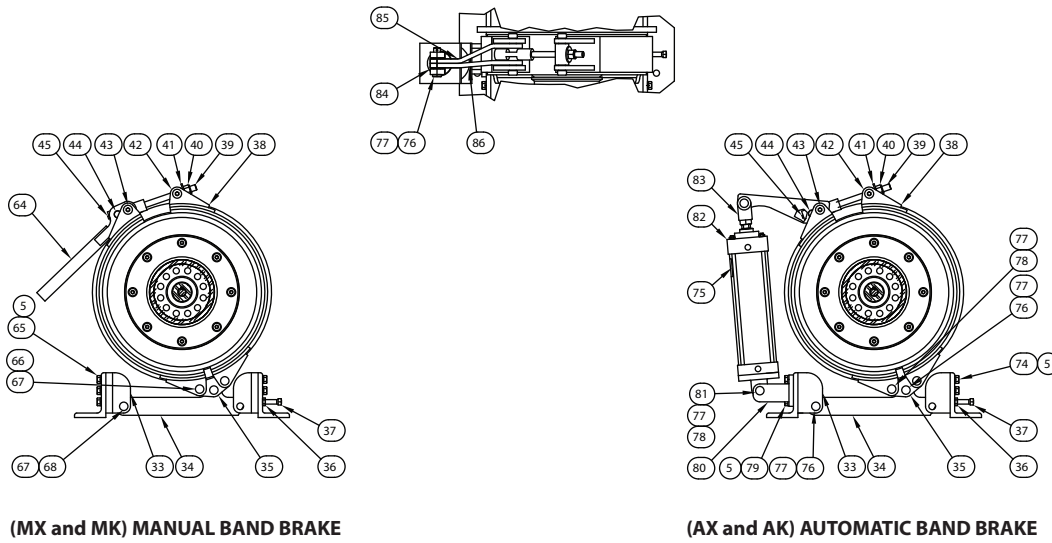

**TA2 SERIES AIR WINCH PARTS LIST (continued from page 37)**

item	description	part number	qty
<b>PENDANT CONTROL VALVE</b>			
56	PENDANT VALVE	B3478	1
57	FITTING HEX NIPPLE 1/8 NPT X -4 JIC	A8347	3
58	FITTING BARBED .25 ID HOSE X -4 JICF	A8348	6
59	HOSE .25 ID .50 OD PUSH ON	A8350	AS REQUIRED
60	FITTING ELBOW MALE 45° 1/4 NPT X -4 JIC	A8848	1
61	FITTING NIPPLE 1/4" NPT X -4 JIC	A8846	2
62	CABLE TIES NYLON .091 X 3.62 LONG	A5048	12
<b>PENDANT PLUMBING WITH TWO AUTO BRAKES</b>			
63	FITTING TEE SWIVEL NUT RUN -4 JIC	A8969	1
<b>MANUAL BAND BRAKE</b>			
64	BRAKE HANDLE	B4407	1
65	CAPSCR HEXHD .500-13NC X 1.500 ZNPL GR5	A3134	5
66	PIN CLEVIS .750 X 3.625 EFF LENGTH ZNPL	A8378	2
67	PIN COTTER .125 X 1.500 STL ZNPL	A4097	4
68	PIN CLEVIS .750 X 2.625 EFF LENGTH ZNPL	A8379	2
69	FITTING ELBOW MALE 90° 1/4" NPT X -4 JIC	A8449	2
70	FITTING ELBOW MALE 45° 1/4" NPT X -4 JIC	A8848	2
71	FITTING HEX NIPPLE 1/4" NPT	A7136	1
72	VALVE QUICK EXHAUST 1/4" NPT	B4585	1
73	FITTING BARBED .25 HOSE -4 JIC SWIVEL FEMALE	A8348	4
<b>AUTOMATIC BAND BRAKE</b>			
74	CAPSCR HEXHD .500-13NC X 1.500 ZNPL GR5	A3134	2
75	LABEL WARNING KEEP HANDS AWAY	A2659	1
76	PIN CLEVIS .750 X 2.625 EFF LENGTH ZNPL	A8379	3
77	PIN COTTER .125 X 1.500 STL ZNPL	A4097	6
78	PIN CLEVIS .750 X 3.625 EFF LENGTH ZNPL	A8378	3
79	CAPSCR HEXHD .500-13NC X 2.000 ZNPL GR5	A2894	3
80	CYLINDER MOUNTING BRACKET	B4623	1
81	SPACER	A8952	1
82	CYLINDER PNEUMATIC SPRING RETURN	C4187	1
83	ROD CLEVIS 3/4-16 FEMALE THREAD	B4587	1
84	WASHER FLAT .765ID X 1.254OD X .060	A8185	2
85	BRAKE LEVER ARM LEFT	C4216	1
86	BRAKE LEVER ARM RIGHT	C4217	1
87	VALVE QUICK EXHAUST 1/2" NPT	B4586	1
88	FITTING HEX REDUCER 1/2" NPT X 1/4" NPT	A8844	1
89	FITTING NIPPLE HEX 1/2" NPT	A5280	1
90	MUFFLER BREATHER 1/2" NPT	A8843	1
91	MUFFLER SHELL 1/2" NPT	A6976	1
92	FITTING BARBED 1/4" ID HOSE X -4 JIC SWIVEL	A8348	10
93	FITTING ELBOW MALE 45° 1/4" NPT X -4 JIC	A8848	4
94	FITTING ELBOW MALE 90° 1/4" NPT X -4 JIC	A8449	4
95	FITTING TEE MALE BRANCH -4 JIC - 1/4 NPT	A8968	1
96	VALVE	B4638	1
97	MOUNTING BRACKET	B4637	1
98	WASHER FLT #10	A4271	4
99	NUT HEX NYLK 10-24NC	A4323	4
100	CAPSCR SOKHD 10-24NC X 2.250	A11971	4
101	CAPSCR HEXHD .500-13NC X 1.000 ZNPL GR5	A3434	1
102	WASHER FLT SAE .500 X 1.062 X .095 ZNPL	A2932	1
103	FITTING PIPE PLUG HEX SOCKET 1/4" NPT	A2797	2
<b>ALL UNITS</b>			
104	LABEL SERIAL TAG	A9544	1
105	LABEL NAMEPLATE THERN LOGO	A6888	1
106	LABEL WARNING KEEP HANDS AWAY	A2659	5
107	LABEL BIG RED	A9451	2
108	LABEL WARNING POWER WINCHES	A9545	1
109	LABEL WARNING CABLE ANCHOR GUARD	A8769	2
110	LABEL WARNING MOTOR/REDUCER LUBE	A8382	2
111	LABEL INSTALL WIRE ROPE	A8384	1
112	LABEL WARNING CABLE ANCHOR PINCH POINT	A9065	1
113	LABEL WARNING ADJUST BRAKE	A8385	1
114	LABEL HAUL IN PAY OUT	A9062	1

### TA2 Series Manual Control Valve and Pendant Control Valve

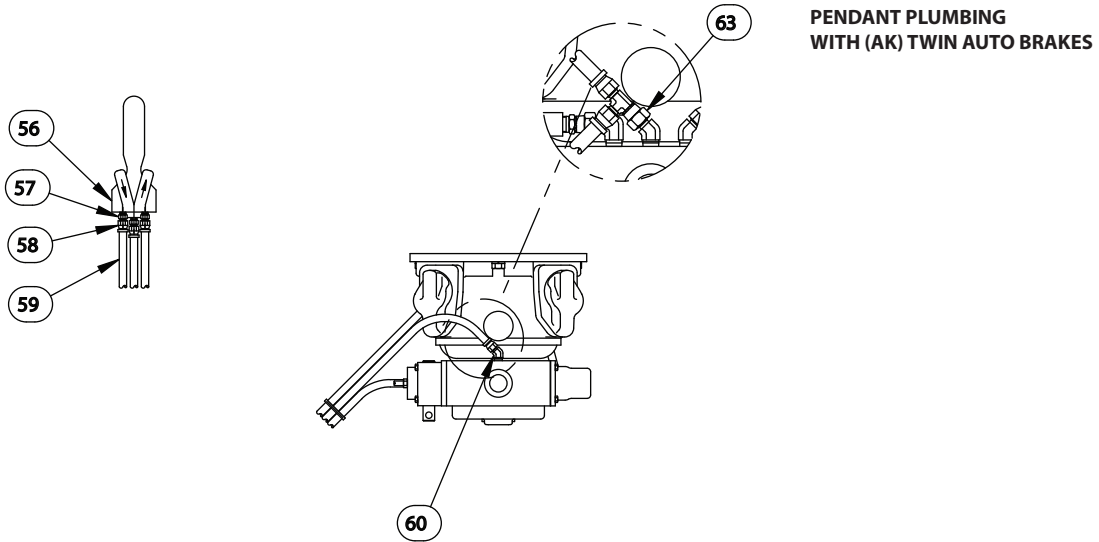

INSTALL 2 PER  
EVERY 5 FEET

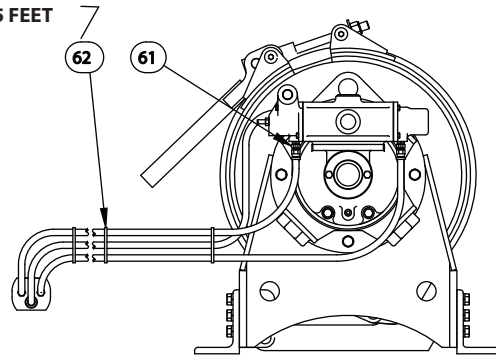

PENDANT CONTROL VALVE  
AND PLUMBING

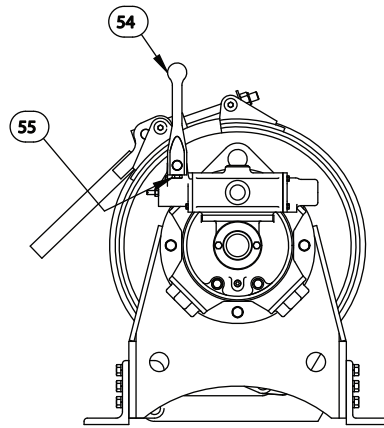

MANUAL CONTROL VALVE



**This page intentionally left blank.**

TA2.5 Series Air Winch  
with disc brake

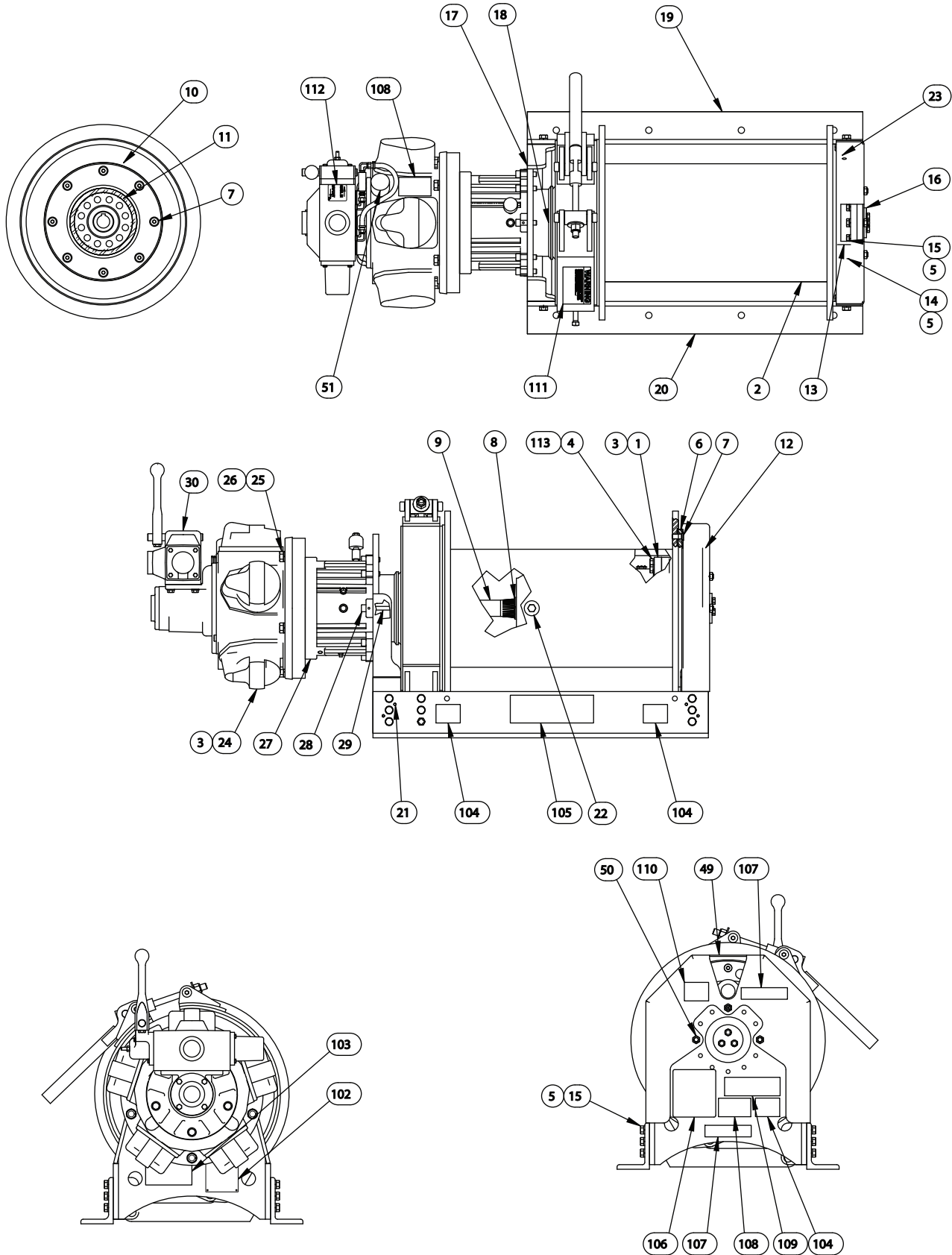

**TA2.5 SERIES AIR WINCH PARTS LIST**

item	description	part number	qty
<b>ALL UNITS</b>			
1	REDUCER ET3067	C3982	1
2*	DRUM MACHINING - TA2.5-16	D2768	1
2*	DRUM MACHINING - TA2.5-24	D2686	1
3	LUBRICANT GEAR	A6939	SEE MANUAL
4	CAPSCR HEXHD .500-13NC X 1.750 ZNPL GR5	A3164	12
5	WASHER HELSPRLK .500 X .873 X .125 ZNPL	A2930	29
6	REDUCER FLANGE	C3988	1
7	CAPSCR SOKFLTHD .500-13NC X 1.250 ZNPL	A8358	16
8	RING RETSPIRAL EXT 1.969 SPRSTL	A8297	1
9*	INPUT SHAFT ASSEMBLY TA2.5-16	B4721	1
9*	INPUT SHAFT ASSEMBLY TA2.5-24	B4723	1
10	BEARING SHAFT MACHINING	B4399	1
11	BEARING BALL	A8299	1
12	REDUCER END PLATE	D2687	1
13	SHAFT HOLDER	B4412	1
14	CAPSCR HEXHD .500-13NC X 2.000 ZNPL GR5	A2894	3
15	CAPSCR HEXHD .500-13NC X 1.500 ZNPL GR5	A3134	21
16	SHAFT COVER	A8389	1
17	MOTOR END PLATE	D2679	1
18	SEAL	A8298	1
19*	REAR FRAME ANGLE - TA2.5-16	C4081	1
19*	REAR FRAME ANGLE - TA2.5-24	C3979	1
20*	FRONT FRAME ANGLE - TA2.5-16	C4082	1
20*	FRONT FRAME ANGLE - TA2.5-24	C3980	1
21	PIN DOWEL .250 X 1.000 ALYSTL	A8359	8
22	PLUG PIPE HEXSOC 1.25-11.5NPT	A8294	2
23	SETSCR SOKHD NYLK .500-13NC X .750 ZNPL	A3713	1
24	MOTOR PISTON RM510	C4306	1
25	CAPSCR HEXHD .625-11NC X 2.000 ZNPL GR5	A3475	5
26	WASHER HELSPRLK .625 X 1.079 X .156 ZNPL	A3078	5
27	BRAKE 165 FT/LB	C4242	1
28	CAPSCR SOKHD .500-13NC X 1.500 ZNPL	A6534	8
29	KEY 10MM X 8MM X 50MM 4140 CD BES	A8450	1
30	VALVE MANUAL CONTROL	B4676	1
31	BRAKE MOUNTING BRACKET	B4405	2
32	BRAKE BAR	B4408	1
33	LOWER LINK PLATE	A8373	2
34	NUT HEX JAM .500-13NC ZNPL GR5	A2893	1
35	SETSCR SQHD .500-13NC X 3.500 ZNPL STL	A2892	1
36	BAND BRAKE	C3972	2
37	BRAKE ADJUSTING LINK	B4404	1
38	NUT HEX NYLK .625-11NC ZNPL GR2	A3072	1
39	WASHER FLT STDPLT .625 X 1.750 X .134 ZN	A3073	1
40	BRAKE ADJUSTING BLOCK	A8376	1
41	SHLDRSCR SOKHD .750 X .625 ZNPL ALYST	A8293	4
42	BRAKE HANDLE PIN TA2 ZNPL	A8377	1
43	SETSCR SOKHD NYLK .312-18NC X .750 SST	A2885	1
44	SHUTTLE VALVE 1/4" NPT	A8770	1
45	FITTING NIPPLE 1/4" NPT X -4 JIC	A8846	1
46	FITTING 1/4" NPT MALE X -4 JIC SWIVEL FEMALE	A8847	1
47	HOSE .25 ID X .50 OD PUSH ON	A8350	AS REQUIRED
48	MUFFLER SHELL 1/4" NPT	A8826	1
49	CABLE ANCHOR GUARD	C4149	1
50	NUT HEX JAM .500-13NC ZNPL GR5	A2893	3
51	FILLER BREATHER HOODED THREADED 3/8 BSP	A9009	1
113	WASHER NORD-LOCK NL1/2" SP .53 X .77 X .10	A12228	12
<b>MANUAL CONTROL VALVE</b>			
52	VALVE HANDLE	B4558	1
53	CAPSCR HEXHD M10-1.5 X 35MM 8.8 ZNPL	A8282	1

\* Items 2, 9, 19 and 20 vary depending on the drum size of the winch.

### TA2.5 Series Brake Plumbing

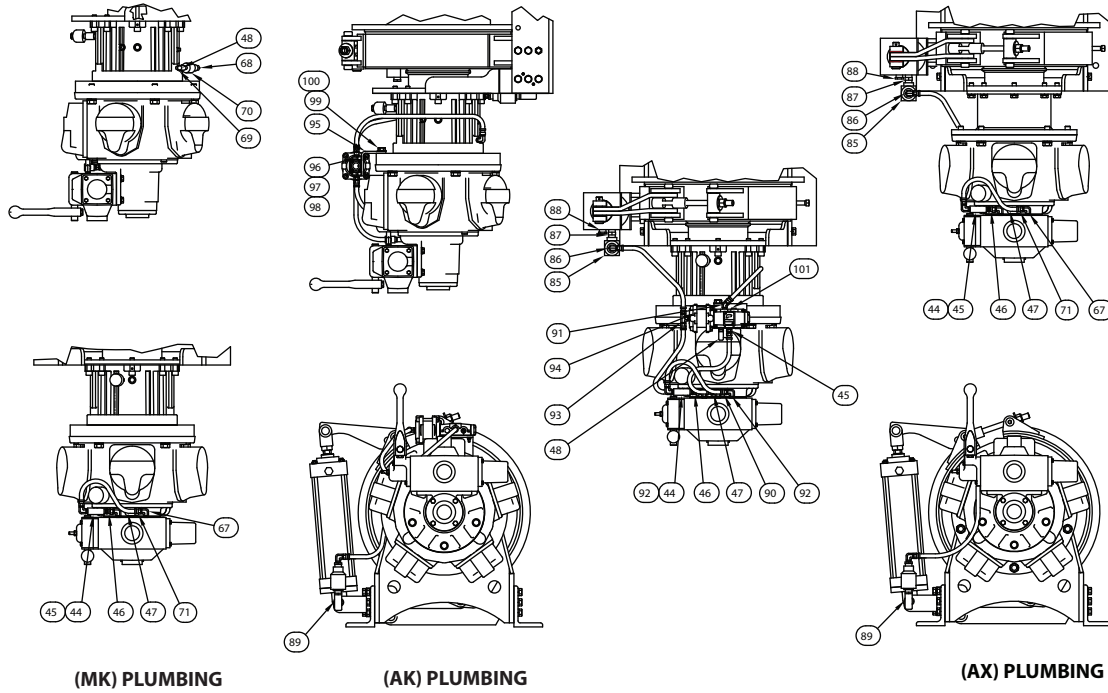

### TA2.5 Series Manual Band Brake and Automatic Band Brake

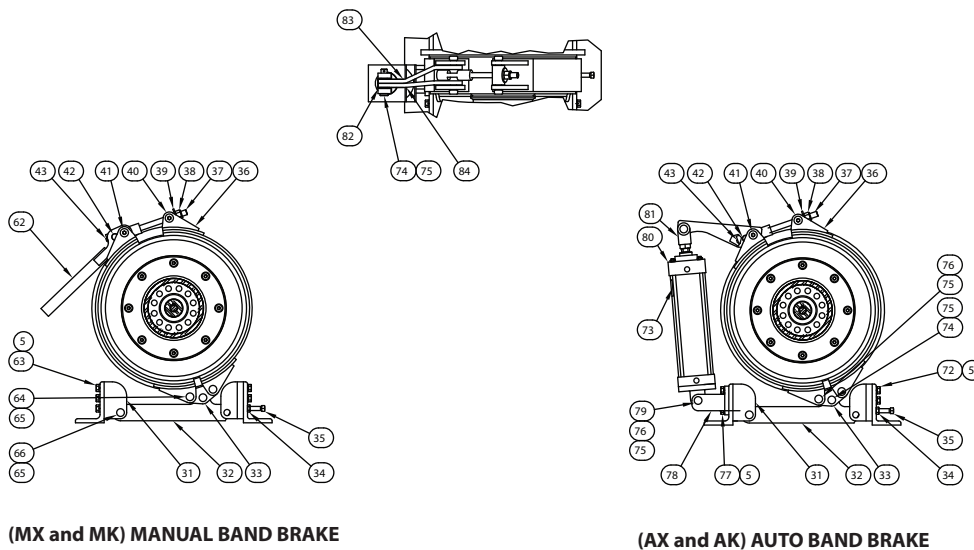

**TA2.5 SERIES AIR WINCH PARTS LIST (continued from page 43)**

item	description	part number	qty
<b>PENDANT CONTROL VALVE</b>			
54	PENDANT VALVE	B3478	1
55	FITTING HEX NIPPLE 1/8 NPT X -4 JIC	A8347	3
56	FITTING BARBED -4 JICF X 1/4" ID HOSE	A8348	6
57	HOSE .25 ID .50 OD PUSH ON	A8350	AS REQUIRED
58	FITTING ELBOW MALE 90° 1/4" NPT X -4 JIC	A8449	1
59	FITTING HEX NIPPLE 1/4 NPT X -4 JIC	A8846	2
60	CABLE TIES NYLON .091 X 3.62 LONG	A5048	12

**PENDANT PLUMBING WITH TWO AUTO BRAKES**

61	FITTING TEE SWIVEL NUT RUN -4 JIC	A8969	1
----	-----------------------------------	-------	---

**MANUAL BAND BRAKE**

62	BRAKE HANDLE	B4407	1
63	CAPSCR HEXHD .500-13NC X 1.500 ZNPL GR5	A3134	5
64	PIN CLEVIS .750 X 3.625 EFF LENGTH ZNPL	A8378	2
65	PIN COTTER .125 X 1.500 STL ZNPL	A4097	4
66	PIN CLEVIS .750 X 2.625 EFF LENGTH ZNPL	A8379	2
67	FITTING ELBOW MALE 90° 1/4" NPT X -4 JIC	A8449	3
68	FITTING ELBOW MALE 45° 1/4" NPT X -4 JIC	A8848	1
69	FITTING HEX NIPPLE 1/4" NPT	A7136	1
70	VALVE QUICK EXHAUST 1/4" NPT	B4585	1
71	FITTING BARBED .25 HOSE -4 JIC SWIVEL FEMALE	A8348	4

**AUTOMATIC BAND BRAKE**

72	CAPSCR HEXHD .500-13NC X 1.500 ZNPL GR5	A3134	2
73	LABEL WARNING KEEP HANDS AWAY	A2659	1
74	PIN CLEVIS .750 X 2.625 EFF LENGTH ZNPL	A8379	3
75	PIN COTTER .125 X 1.500 STL ZNPL	A4097	6
76	PIN CLEVIS .750 X 3.625 EFF LENGTH ZNPL	A8378	3
77	CAPSCR HEXHD .500-13NC X 2.000 ZNPL GR5	A2894	3
78	CYLINDER MOUNTING BRACKET	B4623	1
79	SPACER	A8952	1
80	CYLINDER PNEUMATIC SPRING RETURN	C4187	1
81	ROD CLEVIS 3/4-16 FEMALE THREAD	B4587	1
82	WASHER FLT .765ID X 1.254OD X .060	A8185	2
83	BRAKE LEVER ARM LEFT	C4216	1
84	BRAKE LEVER ARM RIGHT	C4217	1
85	VALVE QUICK EXHAUST 1/2" NPT	B4586	1
86	FITTING HEX REDUCER 1/2" NPT X 1/4" NPT	A8844	1
87	FITTING NIPPLE HEX 1/2" NPT	A5280	1
88	MUFFLER BREATHER 1/2" NPT	A8843	1
89	MUFFLER SHELL 1/2" NPT	A6976	1
90	FITTING BARBED 1/4" ID HOSE X -4 JIC SWIVEL	A8348	10
91	FITTING ELBOW MALE 45° 1/4" NPT X -4 JIC	A8848	1
92	FITTING ELBOW MALE 90° 1/4" NPT X -4 JIC	A8449	7
93	FITTING TEE MALE BRANCH -4 JIC X 1/4" NPT	A8968	1
94	VALVE	B4638	1
95	MOUNTING BRACKET	B4637	1
96	WASHER FLT #10	A4271	4
97	NUT HEX NYLK 10-24NC	A4323	4
98	CAPSCR SOKHD 10-24NC X 2.250	A11971	4
99	CAPSCR HEXHD .625-11NC X 1.250 ZNPL GR5	A6916	1
100	WASHER FLT STDPLT .625 X 1.750 X .134 ZNPL	A3073	1
101	FITTING PIPE PLUG HEX SOCKET 1/4" NPT	A2797	2

**ALL UNITS**

102	LABEL NAMEPLATE POWER WINCHES	A9544	1
103	LABEL NAMEPLATE THERN LOGO	A6888	1
104	LABEL WARNING KEEP HANDS AWAY	A2659	5
105	LABEL BIG RED	A9451	2
106	LABEL WARNING POWER WINCHES	A9545	1
107	LABEL WARNING CABLE ANCHOR GUARD	A8769	2
108	LABEL WARNING MOTOR/REDUCER LUBE	A8382	2
109	LABEL INSTALL WIRE ROPE	A8384	1
110	LABEL WARNING CABLE ANCHOR PINCH POINT	A9065	1
111	LABEL WARNING ADJUST BRAKE	A8385	1

**MANUAL CONTROL VALVE**

112	LABEL HAUL IN PAY OUT	A9062	1
-----	-----------------------	-------	---

### TA2.5 Series Manual Control Valve and Pendant Control Valve

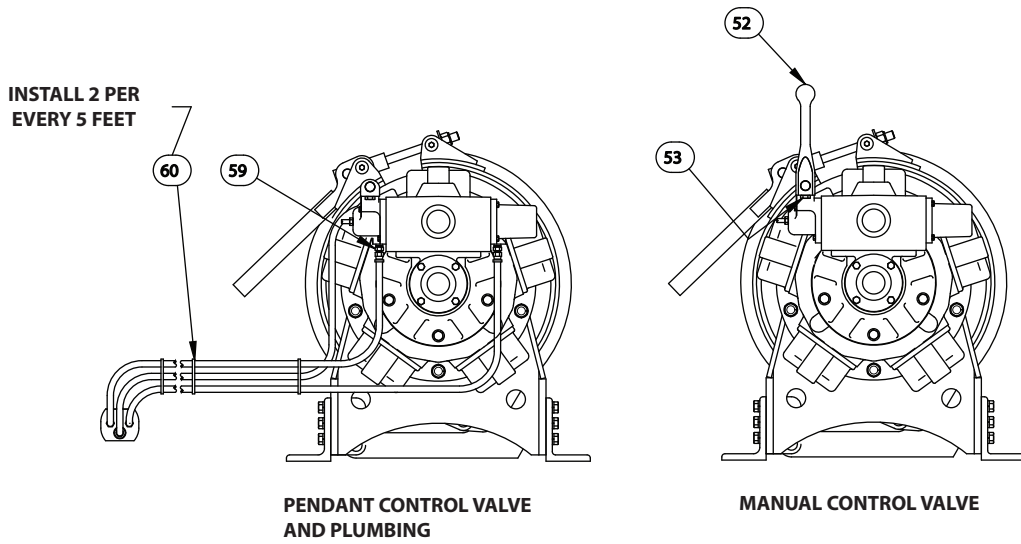
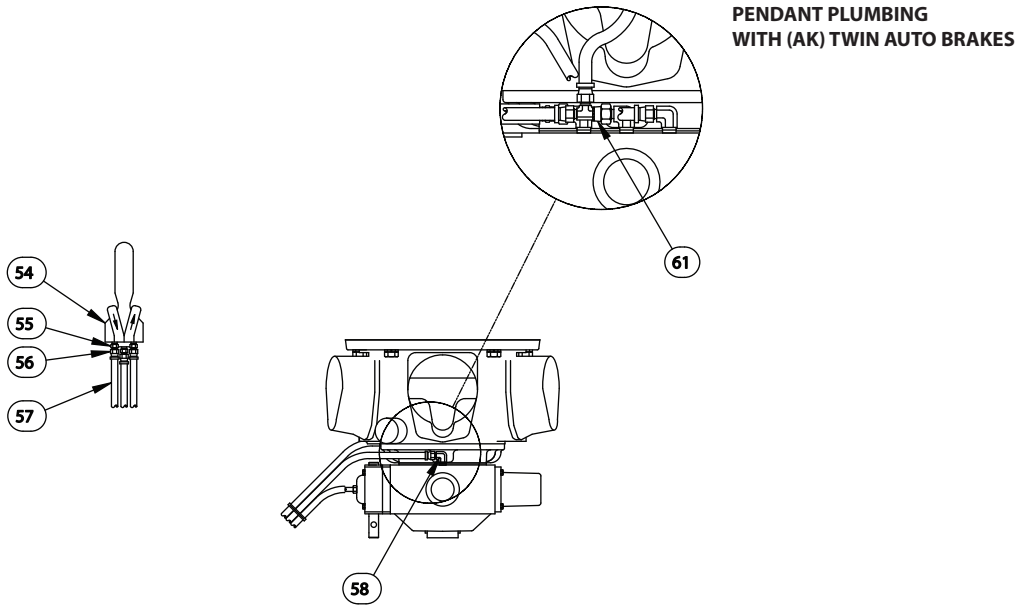

**This page intentionally left blank.**

TA5 Series Air Winch  
with disc brake

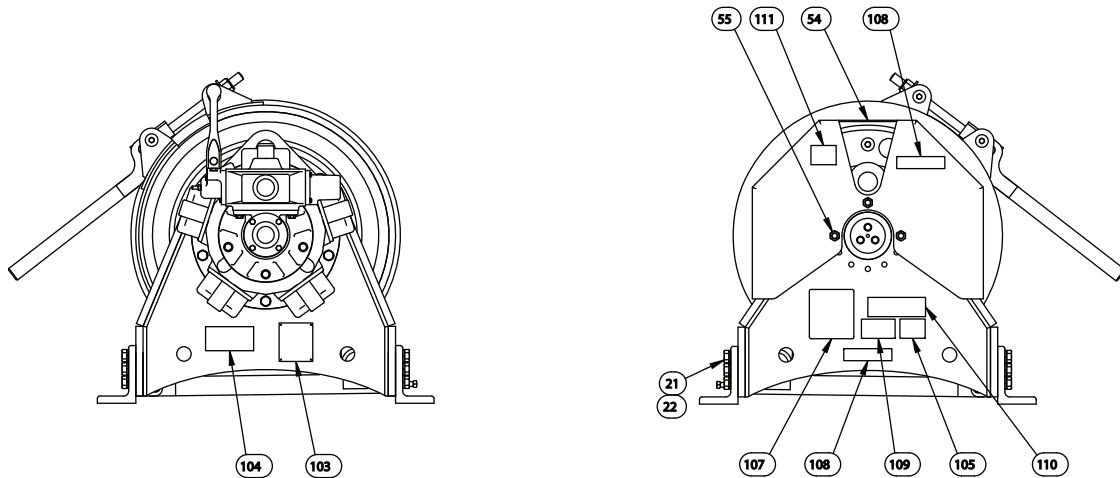
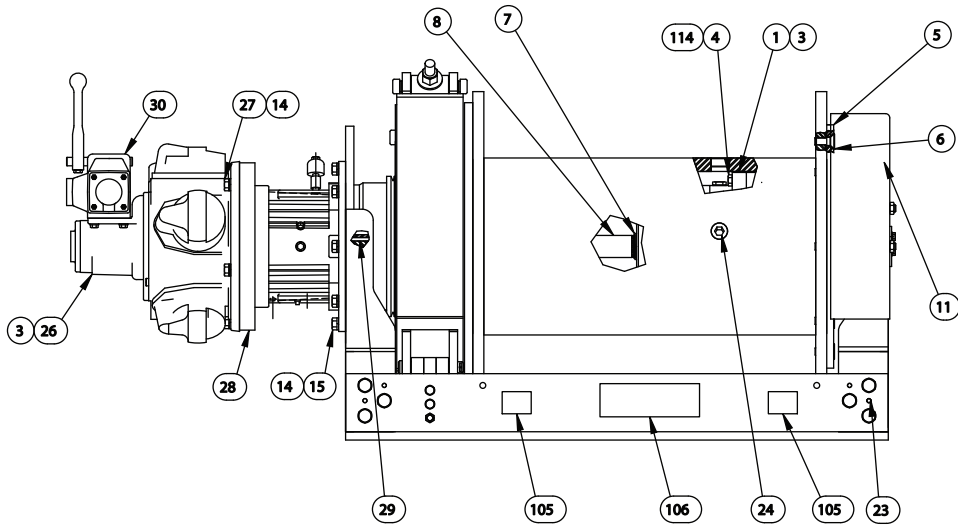
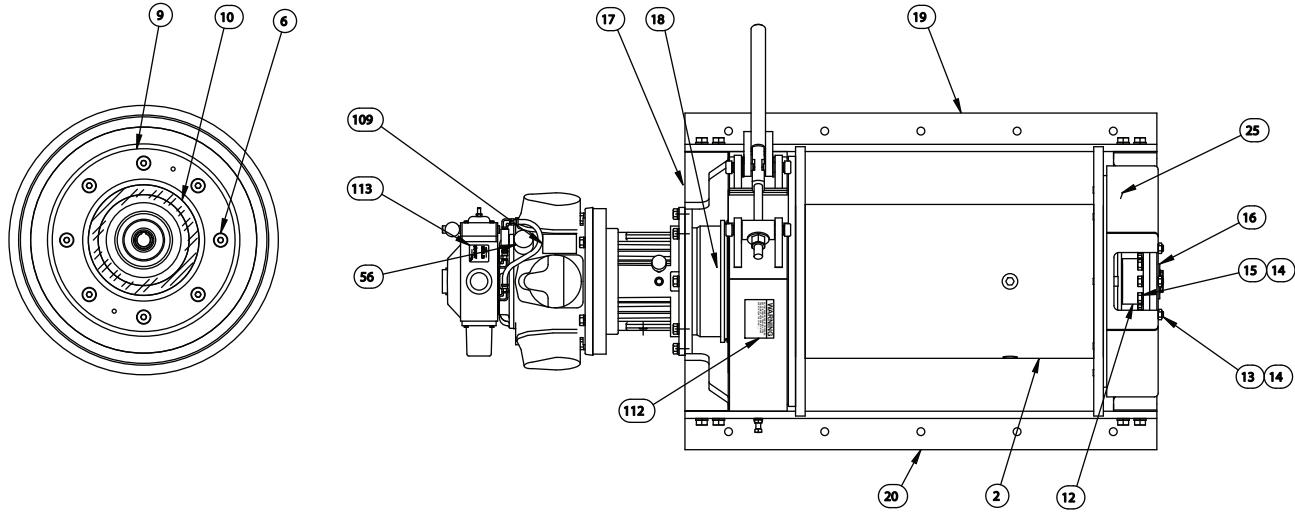



## TA5 SERIES AIR WINCH PARTS LIST

item	description	part number	qty
<b>ALL UNITS</b>			
1	REDUCER ET3155 140.4:1	C3983	1
2*	MACHINING DRUM TA5-16	D2840	1
2*	MACHINING DRUM TA5-24	D2832	1
2*	MACHINING DRUM TA5-30	D2695	1
3	LUBRICANT GEAR	A6939	SEE MANUAL
4	CAPSCR HEXHD .562-12NC X 6.000 ZNPL GR8	A8827	12
5	MACHINING REDUCER MOUNT TA5	D2692	1
6	CAPSCR SOKFLTHD .750-10NC X 1.750 ZNPL	A8469	16
7	RING RET EXT 1.969 SPRSTL	A8297	1
8*	INPUT SHAFT ASSEMBLY TA5-16	B4722	1
8*	INPUT SHAFT ASSEMBLY TA5-24	B4725	1
8*	INPUT SHAFT ASSEMBLY TA5-30	B4727	1
9	MACHINING SHAFT DRUM TA5	C3992	1
10	BRG RAD BALL 4.3307 X 9.4488 X 1.9685	A8474	1
11	MACHINING REDUCER END PLATE TA5	D2693	1
12	HOLDER OUTPUT SHAFT FR 150	B4415	1
13	CAPSCR HEXHD .625-11NC X 2.250 ZNPL GR8	A8828	3
14	WASHER HELSPRLK .625 X 1.079 X .156 ZNPL	A3078	25
15	CAPSCR HEXHD .625 X 1.500 ZNPL GR8	A8829	17
16	COVER SHAFT RDF 150	A8405	1
17	MACHINING BEARING END PLATE TA5	D2694	1
18	SEAL OIL CR VR2 TYPE CR #403000	A8470	1
19*	REAR FRAME ANGLE TA5-16	D2835	1
19*	REAR FRAME ANGLE TA5-24	D2827	1
19*	REAR FRAME ANGLE TA5-30	D2712	1
20*	FRONT FRAME ANGLE TA5-16	D2836	1
20*	FRONT FRAME ANGLE TA5-24	D2828	1
20*	FRONT FRAME ANGLE TA5-30	D2713	1
21	CAPSCR HEXHD .750-10NC X 1.750 ZNPL GR8	A4911	12
22	WASHER HELSPRLK .750 X 1.271 X .188 ZNPL	A3230	12
23	PIN DOWEL .375 X 1.500 ALYSTL	A8473	8
24	PLUG PIPE HEXSOC 1.25-11.5 NPT	A8294	3
25	SETSCR SOKHD .750-10NC X 1.000 ZNPL ALYSTL	A3741	1
26	MOTOR PISTON RM510	C4306	1
27	CAPSCR HEXHD .625-11NC X 2.000 ZNPL GR5	A3475	5
28	BRAKE 165 FT/LB	C4243	1
29	KEY 10MM X 8MM X 50MM 4140 CD BES	A8450	1
31	PIN CLEVIS 1.000 X 3.375 EFF LENGTH	A8456	1
32	MACHINING SPACER MOUNT TA5	B4443	1
33	MACHINING SPACER BAR TA5	B4438	1
34	PIN CLEVIS 1.000 X 5.125 EFF LENGTH	A8457	2
35	PIN CLEVIS 1.000 X 4.625 EFF LENGTH	A8458	1
36	BRAKE MOUNTING PLATE TA2	A8372	1
37	NUT HEX JAM .500-13NC ZNPL GR5	A2893	1
38	SETSCR SQHD .500-13NC X 3.500 ZNPL STL	A2892	1
39	LINK BRAKE TA5	B4439	3
40	BAND BRAKE HALF TA5	C4013	2
41	BRAKE TOP LINK ASSEMBLY	B4449	1
42	NUT HEX NYLK .875-9NC ZNPL GR2	A3515	1
43	WASHER FLT STDPLT .875 X 2.250 X 165 ZNPL	A3590	1
44	BLOCK BRAKE ADJUSTMENT	A8462	1
45	SHLDSCR SOKHD 1.000 X 1.250 ZNPL	A8471	4
46	WASHER FLT SAE 1.000 X 2.000 X .134 ZNPL	A3085	2
47	PIN TOP LINK	A8468	1
48	SETSCR SOKHD NYLK .312-18NC X .750 SST	A2885	1
49	VALVE SHUTTLE 1/4 NPT	A8770	1
50	FITTING NIPPLE .438-20 JIC X .250 NPTM	A8846	1
51	FITTING SWIVEL .438-20 JICF X .250 NPTM	A8847	1
52	HOSE PUSH-ON .25 ID X .50 OD PUSH ON	A8350	AS REQUIRED
53	MUFFLER SHELL TYPE .25 NPT MALE	A8826	1
54	GUARD CABLE ANCHOR TA5	D2819	1
55	NUT HEX JAM .625-11NC ZNPL GR2	A3574	3
56	FILLER BREATHER HOODED THREADED 3/8 BSP	A9009	1
114	WASHER NORD-LOCK NL14 .6 X .91 X .13	A12229	12

\* Items 2, 8, 19 and 20 vary depending on the drum size of the winch.

### TA5 Series Brake Plumbing

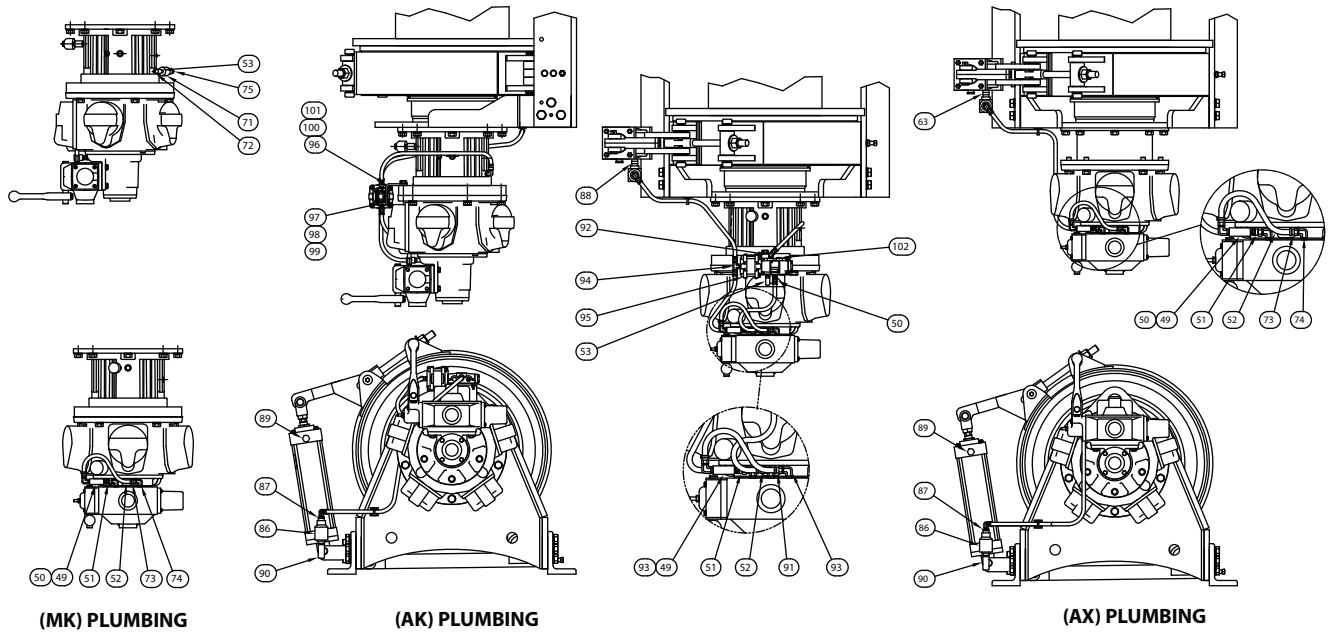

### TA5 Series Manual Band Brake and Automatic Band Brake

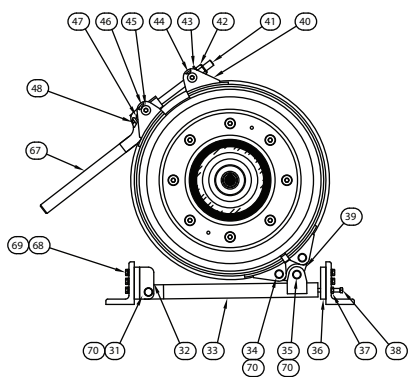

(MX and MK) MANUAL BAND BRAKE

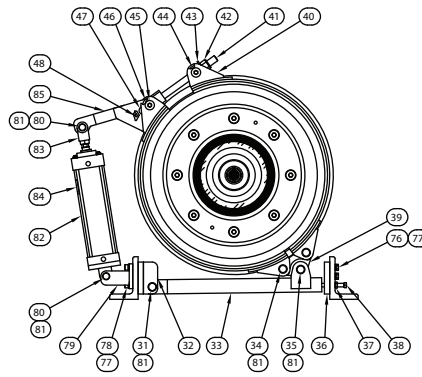

(AX and AK) AUTOMATIC BAND BRAKE

**TA5 SERIES AIR WINCH PARTS LIST (continued from page 49)**

item	description	part number	qty
<b>MANUAL CONTROL VALVE</b>			
57	MACHING VALVE HANDLE TA SERIES	B4558	1
58	CAPSCR HEXHD M10-1.5 X 35MM 8.8 ZNPL	A8282	1
<b>PENDANT CONTROL VALVE</b>			
59	VALVE PENDANT FENNER PC2	B3478	1
60	FITTING NIPPLE .438-20 JIC X .125 NPTM	A8347	3
61	FITTING BARBED .25 ID HOSE X .438-20 JIC	A8348	6
62	HOSE PUSH-ON .25 ID X .50 OD PUSH ON	A8350	AS REQUIRED
63	FITTING 90 .438-20 JIC X .250 NPTM	A8449	1
64	FITTING NIPPLE .438-20 JIC X .250 NPTM	A8846	2
65	CABLE TIES NYLON T&B .091 X 3.62 LONG	A5048	12
30	VALVE	B4581	1
<b>PENDANT PLUMBING WITH TWO AUTO BRAKES</b>			
66	FITTING TEE SWIVEL NUT RUN -4 JIC	A8969	1
<b>MANUAL BAND BRAKE</b>			
67	MACHINING HANDLE	C4021	1
68	CAPSCR HEXHD .500-13NC X 1.500 ZNPL GR5	A3134	5
69	WASHER HELSPRLK .500 X .873 X .125 ZNPL	A2930	5
70	PIN COTTER .125 X 1.500 STL ZNPL	A4097	4
71	VALVE QUICK EXHAUST 1/4" NPT	B4585	1
72	FITTING NIPPLE HEX .250-28NPT	A7136	1
73	FITTING BARBED .25 ID HOSE X .438-20 JIC	A8348	4
74	FITTING ELBOW MALE 90° 1/4" NPT X -4 JIC	A8449	3
75	FITTING ELBOW MALE 45° 1/4" NPT X -4 JIC	A8848	1
<b>AUTOMATIC BAND BRAKE</b>			
76	CAPSCR HEXHD .500-13NC X 1.500 ZNPL GR5	A3134	2
77	WASHER HELSPRLK .500 X .873 X .125 ZNPL	A2930	5
78	CAPSCR SOKHD .500-13NC X 2.000 ZNPL	A9349	3
79	MACHINING MOUNTING CYLINDER	B4584	1
80	PIN CLEVIS .750 X 2.626 EFF LENGTH ZNPL	A8379	2
81	PIN COTTER .125 X 1.500 STL ZNPL	A4097	6
82	CYLINDER PNEU 4" BORE 6"STROKE SPRNG RET	C4187	1
83	ROD CLEVIS 3/4-16 FEMALE THREADED	B4587	1
84	LABEL WARNING KEEP HANDS AWAY FROM DRUM	A2659	1
85	MACHINING BRAKE LEVER TA5	B4594	1
86	VALVE QUICK EXHAUST 1/2" NPT	B4586	1
87	FITTING HEX REDUCER .500-14M X .250-18F	A8844	1
88	FITTING NIPPLE HEX .500-14 NPT	A5280	1
89	MUFFLER BREATHER TYPE 1/2" NPT MALE	A8843	1
90	MUFFLER SHELL TYPE .50 NPT MALE	A6976	1
91	FITTING BARBED .25 ID HOSE X .438-20 JIC	A8348	10
92	FITTING EL45DEG .438-20 JICM X .250 NPTM	A8848	1
93	FITTING ELBOW MALE 90° 1/4" NPT X -4 JIC	A8449	7
94	FITTING TEE MALE BRANCH -4 JIC - 1/4NPT	A8968	1
95	VALVE DIR CONTROL PNEU 2POS SPRNG RETURN	B4638	1
96	BRACKET VALVE MOUNT AAA OP2 TA SERIES	B4637	1
97	WASHER FLT #10	A4271	4
98	NUT HEX NYLK 10-24NC	A4323	4
99	CAPSCR SOKHD 10-24NC X 2.250	A11971	4
100	CAPSCR HEXHD .625-11NC X 1.250 ZNPL GR5	A6916	1
101	WASHER FLT STDPLT .625 X 1.750 X .134 ZNPL	A3073	1
102	PLUG PIPE HEXSOC .250-18NPT X .425 SAE	A2797	2
<b>ALL UNITS</b>			
103	LABEL NAMEPLATE POWER WINCHES	A9544	1
104	LABEL NAMEPLATE THERN LOGO	A6888	1
105	LABEL WARNING KEEP HANDS AWAY FROM DRUM	A2659	5
106	LABEL BIG RED	A9451	2
107	LABEL WARNING READ FOR POWER WINCHES	A9545	1
108	LABEL WARNING DO NOT OPERATE WITH CABLE	A8769	2
109	LABEL CAUTION LUBE MOTOR/REDUCER TA	A8382	2
110	LABEL WARNING INSTALL WIRE ROPE TA	A8384	1
111	LABEL CABLE ANCHOR PINCH POINT	A9065	1
112	LABEL WARNING ADJUST BAND BRK TA SERIES	A8385	1
113	LABEL HAUL IN / PAY OUT TA SERIES	A9062	1

### TA5 Series Manual Control Valve and Pendant Control Valve

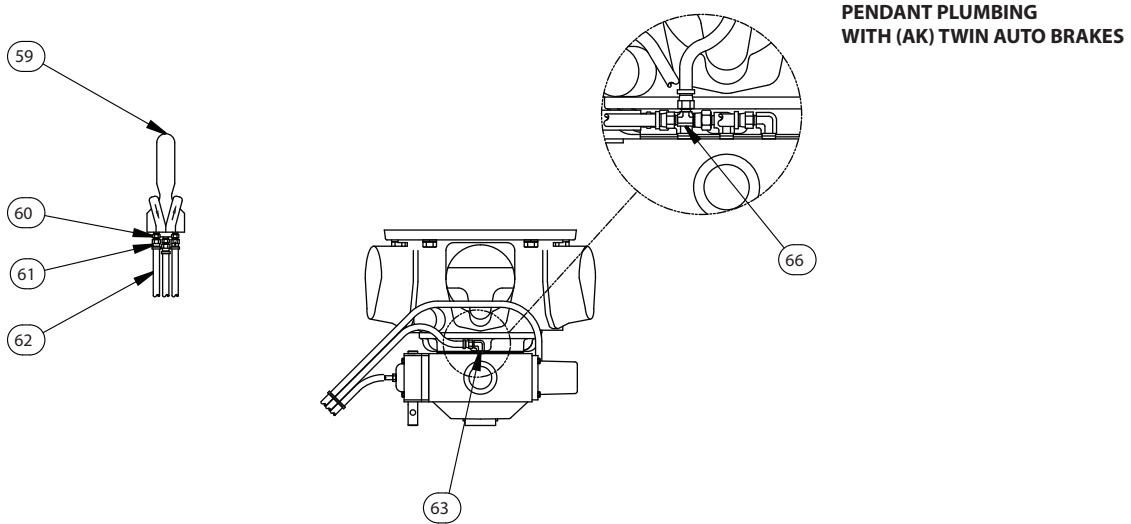

INSTALL 2 PER  
EVERY 5 FEET

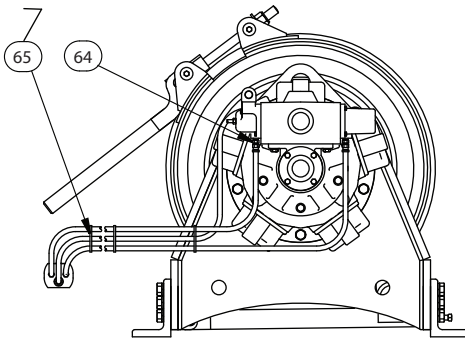

PENDANT CONTROL VALVE  
AND PLUMBING

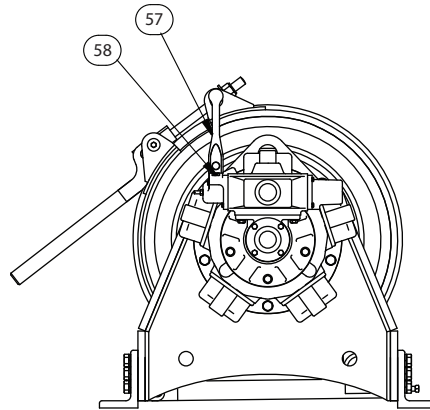

MANUAL CONTROL VALVE

**This page intentionally left blank.**



## TA7 SERIES AIR WINCH PARTS LIST

item	description	part number	qty
<b>ALL UNITS</b>			
1*	MACHINING DRUM TA7-24	D2855	1
1*	MACHINING DRUM TA7-30	D2847	1
1*	MACHINING DRUM TA7-36	D2697	1
2	REDUCER EQ4255 238.26:1	D2683	1
3	LUBRICANT GEAR	A6939	SEE MANUAL
4	CAPSCR SOKHD M16-2 X 260MM 12.9 ZNPL	A12245	15
5**	NUT HEX M16-2.00 ZNPL CL10	A12246	15
6	MACHINING REDUCER MOUNTING ADAPTER TA7	D2696	1
7	CAPSCR SOKFLTHD .750-10NC X 1.750	A8469	16
8	RING RET EXT 1.969	A8297	1
9*	INPUT SHAFT ASSEMBLY TA7-24	B4724	1
9*	INPUT SHAFT ASSEMBLY TA7-30	B4726	1
9*	INPUT SHAFT ASSEMBLY TA7-36	B4728	1
10	MACHINING SHAFT DRUM TA7	C3993	1
11	BRG RAD BALL 4.3307 X 9.4488 X 1.9685	A8478	1
12	MACHINING REDUCER END PLATE TA7	D2698	1
13	HOLDER OUTPUT SHAFT BREVINI FR 250	B4416	1
14	TAP BOLT HEXHD .750-10NC X 3.00 GR5	A8774	3
15	WASHER HELSPRLK .750 X 1.271 X .188	A3230	12
16	CAPSCR HEXHHD .750-10NC X 2.000 GR5	A8475	9
17	COVER SHAFT BREVINI RDF 250	A8406	1
18	MACHINING BEARING END PLATE TA7	D2699	1
19	SEAL OIL CR VR2 TYPE	A8470	1
20	SEAL OIL 110MM X 140MM X 12MM	A8480	1
21	SEAL OIL 8.00ID X 10.000D X .625	A8481	1
22*	REAR FRAME ANGLE TA7-24	D2851	1
22*	REAR FRAME ANGLE TA7-30	D2843	1
22*	REAR FRAME ANGLE TA7-36	D2714	1
23*	FRONT FRAME ANGLE TA7-24	D2852	1
23*	FRONT FRAME ANGLE TA7-30	D2844	1
23*	FRONT FRAME ANGLE TA7-36	D2715	1
24	PIN DOWEL .500 X 1.750	A8482	8
25	CAPSCR HEXHD 1.000-8NC X 2.250 GR8	A8476	8
26	WASHER HELSPRLK 1.000 X 1.661 X .250	A3586	8
27	PLUG PIPE HEXSOC 1.25-11.5NPT	A8294	3
28	SETSCR SOKHD .750-10NC X 1.000	A3741	1
29	MACHINING MOTOR ADAPTER RM510	C4335	1
30	MOTOR PISTON RM510	C3989	1
31	CAPSCR HEXHD .625-11NC X 1.750 GR5	A3077	8
32	WASHER LOCK .625	A3078	13
33	KEY 10MM X 8MM X 50MM 4140 CD BES	A8450	1
34	CAPSCR HEXHD .625-11NC X 2.000 GR5	A3475	5
35	LUBRICANT GEAR	A6939	38
36	BRAKE 165 FT/LB	C4243	1
37	MOTOR PISTON RM510	C4306	1
110**	WASHER NORD-LOCK NL16 .67 X1 X.13	A12230	30

## MANUAL CONTROL VALVE

38	VALVE MOTOR CONTROL	B4676	1
39	VALVE HANDLE	B4558	1
40	CAPSCR HEXHD 10MM X 35MM	A8282	1

## PENDANT CONTROL VALVE

41	VALVE PILOT OPERATED	B4581	1
42	VALVE PENDANT	B3478	1
43	FITTING NIPPLE 1/8" NPT X -4 JIC	A8347	3
44	FITTING BARBED 1/4" ID HOSE X -4 JIC SWIVEL	A8348	6
45	HOSE PUSH-ON .25 ID X .50 OD PUSH ON	A8350	AS REQUIRED
46	FITTING ELBOW MALE 90° 1/4" NPT X -4 JIC	A8449	1
47	FITTING NIPPLE 1/4" NPT X -4 JIC	A8846	2
48	CABLE TIES NYLON T&B .091 X 3.62 LONG	A5048	12

## PENDANT PLUMBING WITH TWO AUTO BRAKES

49	FITTING TEE SWIVEL NUT RUN -4 JIC	A8969	1
----	-----------------------------------	-------	---

\* Items 1, 9, 22 and 23 vary depending on the drum size of the winch.

\*\* Torque item 5 to 269 lb-ft (365 N•m).

\*\*\* 1 each item 110 installed to both ends of item 4.

### TA7 Series Brake Plumbing

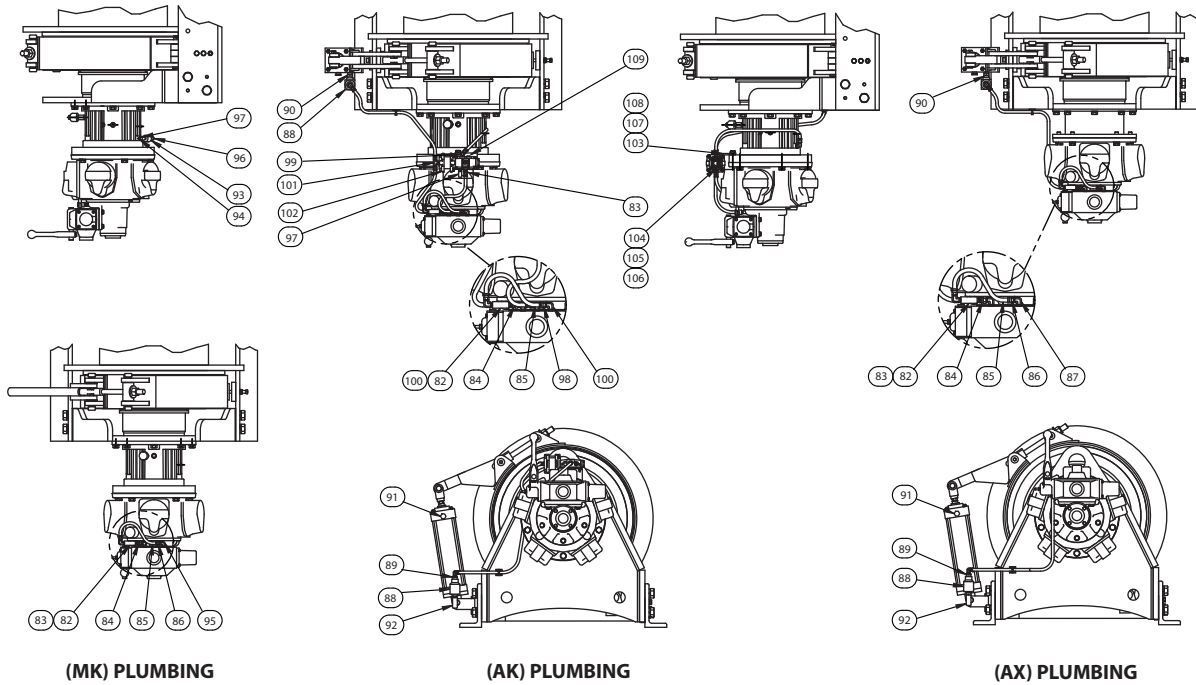

---

### TA7 Series Manual Band Brake and Automatic Band Brake

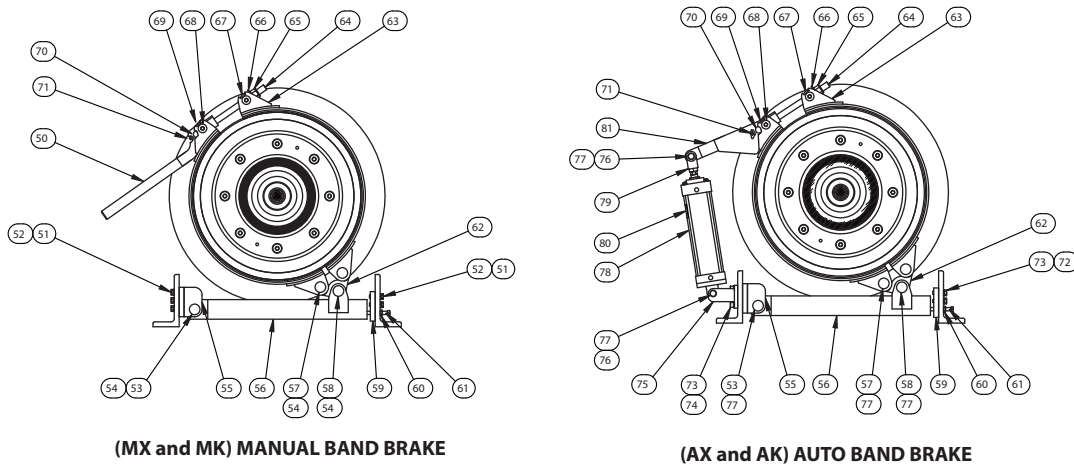



**TA7 SERIES AIR WINCH PARTS LIST (continued from page 55)**

item	description	part number	qty
<b>MANUAL BAND BRAKE</b>			
50	MACHINING HANDLE	C4021	1
51	WASHER LOCK .500	A2930	5
52	CAPSCR HEXHD .500-13NC X 1.750 GR5	A3164	5
53	PIN CLEVIS 1.250 X 4.750	A8465	1
54	PIN COTTER .156 X 2.000	A8477	4
55	MACHINING SPACER MOUNT TA7	B4452	1
56	MACHINING SPACER BAR TA7	B4447	1
57	PIN CLEVIS 1.250 X 5.250	A8467	2
58	PIN CLEVIS 1.250 X 3.500	A8466	1
59	BRAKE MOUNTING PLATE	A8372	1
60	NUT HEX JAM .500-13NC GR5	A2893	1
61	SETSCR SQHD .500-13NC X 3.500 STL	A2892	1
62	LINK BRAKE TA7	B4453	3
63	BAND BRAKE HALF TA7	C4012	2
64	BRAKE TOP LINK ASSEMBLY	B4449	1
65	NUT HEX NYLK .875-9NC	A3515	1
66	WASHER FLAT .875	A3590	1
67	BLOCK BRAKE ADJUSTMENT	A8462	1
68	SHLDRSCR SOKHD 1.000 X 1.250	A8471	4
69	WASHER FLAT 1.000	A3085	2
70	PIN TOP LINK	A8468	1
71	SETSCR SOKHD NYLK .312-18NC X .750 SST	A2885	1
<b>AUTOMATIC BAND BRAKE</b>			
72	CAPSCR HEXHD .500-13NC X 1.750 GR5	A3164	2
73	WASHER LOCK .500	A2930	5
74	CAPSCR SOKHD .500-13NC X 2.000	A3535	3
75	MACHINING MOUNTING CYLINDER TA7	B4608	1
76	PIN CLEVIS .750 X 2.625	A8379	2
77	PIN COTTER .156 X 2.000	A8477	6
78	CYLINDER PNEU 4" BORE 6" STROKE SPRNG RET	C4187	1
79	ROD CLEVIS 3/4-16 FEMALE THREADED	B4587	1
80	LABEL WARNING KEEP HANDS AWAY FROM DRUM	A2659	1
81	MACHINING BRAKE LEVER TA7	B4687	1
<b>BRAKE PLUMBING</b>			
82	VALVE SHUTTLE 1/4" NPT	A8770	1
83	FITTING NIPPLE 1/4" NPT X -4 JIC	A8846	1
84	FITTING 1/4" NPT MALE X -4 JIC SWIVEL FEMALE	A8847	1
85	HOSE PUSH-ON .25 ID X .50 OD PUSH ON	A8350	AS REQUIRED
86	FITTING BARBED 1/4" ID HOSE X -4 JIC SWIVEL	A8348	4
87	FITTING ELBOW MALE 90° 1/4" NPT X -4 JIC	A8449	4
88	VALVE QUICK EXHAUST 1/2" NPT	B4586	1
89	FITTING HEX REDUCER 1/2" NPT X 1/4" NPT	A8844	1
90	FITTING NIPPLE HEX 1/2" NPT	A5280	1
91	MUFFLER BREATHER 1/2" NPT	A8843	1
92	MUFFLER SHELL TYPE 1/2" NPT	A6976	1
93	VALVE QUICK EXHAUST 1/4" NPT	B4585	1
94	FITTING NIPPLE HEX 1/4" NPT	A7136	1
95	FITTING ELBOW MALE 90° 1/4" NPT X -4 JIC	A8449	3
96	FITTING ELBOW MALE 45° 1/4" NPT X -4 JIC	A8848	1
97	MUFFLER SHELL TYPE 1/4" NPT	A8826	1
98	FITTING BARBED 1/4" ID HOSE X -4 JIC SWIVEL	A8348	10
99	FITTING ELBOW MALE 45° 1/4" NPT X -4 JIC	A8848	1
100	FITTING ELBOW MALE 90° 1/4" NPT X -4 JIC	A8449	7
101	FITTING TEE MALE BRANCH -4 JIC - 1/4 NPT	A8968	1
102	VALVE	B4638	1
103	VALVE MOUNTING BRACKET	B4637	1
104	WASHER FLAT #10	A4271	4
105	NUT HEX NYLK 10-24NC	A4323	4
106	CAPSCR SOKHD 10-24NC X 2.250	A11971	4
107	CAPSCR HEXHD .625-11NC X 1.250 GR5	A6916	1
108	WASHER FLAT .625	A3073	1
109	PLUG PIPE HEXSOC 1/4" NPT	A2797	2

### TA7 Series Manual Control Valve and Pendant Control Valve

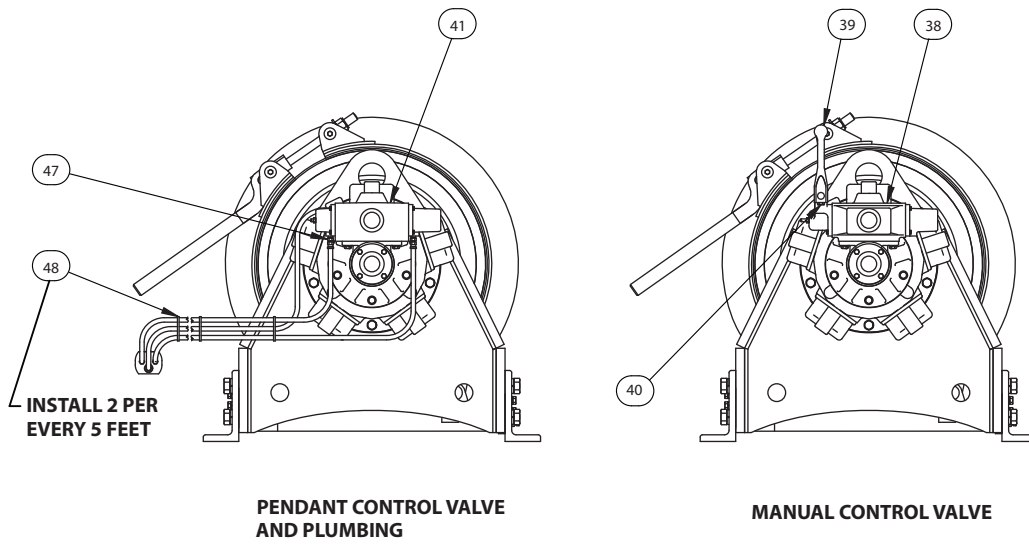
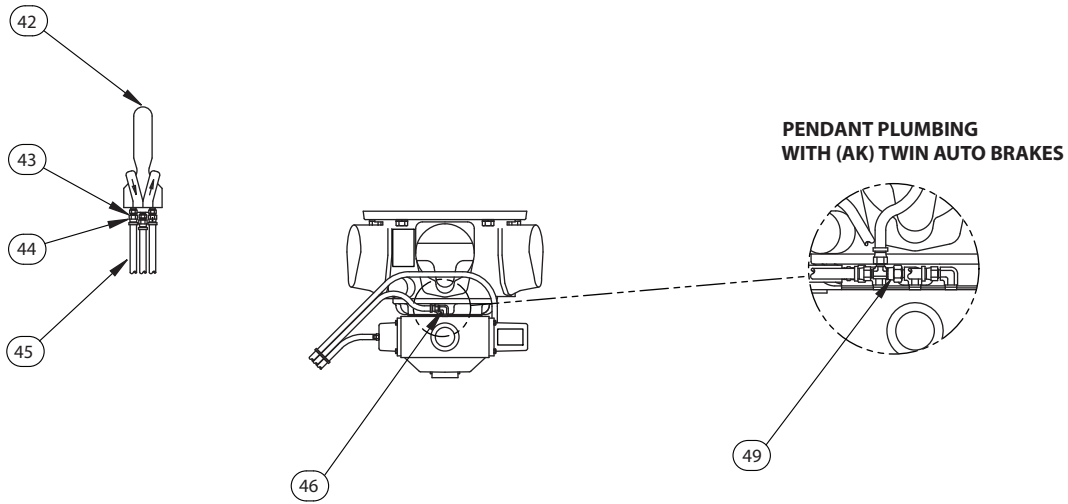

**TA7 SERIES AIR WINCH PARTS LIST (continued from page 57)**

item	description	part number	qty
<b>ALL UNITS</b>			
110	GUARD CABLE ANCHOR TA7	D2822	1
111	NUT HEX JAM .750-10NC GR2	A3157	3
112	FILLER BREATHER	A9009	1
113	LABEL NAMEPLATE POWER WINCHES	A5923	1
114	LABEL NAMEPLATE THERN	A6888	1
115	LABEL WARNING KEEP HANDS AWAY FROM DRUM	A2659	5
116	LABEL BIG RED	A9451	2
117	LABEL WARNING READ... FOR POWER WINCHES	A1980	1
118	LABEL WARNING DO NOT OPERATE WITH CABLE	A8769	2
119	LABEL CAUTION LUBE MOTOR/REDUCER	A8382	2
120	LABEL WARNING INSTALL WIRE ROPE	A8384	1
121	LABEL CABLE ANCHOR PINCH POINT	A9065	1
122	LABEL HAUL IN / PAY OUT	A9062	1
123	LABEL WARNING ADJUST BAND BRAKE	A8385	1
124	LABEL THIS WINCH HAS NO AUTOMATIC BRAKE	A2692	1

**TA2 SERIES - ASSEMBLY**

item	description	part number	qty
1	CONTROL VALVE MANUAL	B4675	1
1*	CONTROL VALVE FOR PENDANT	B4580	1
2	PISTON AIR MOTOR	C3937	1
3	MOTOR ADAPTER	B4803	1
3**	BRAKE 54 FT / LB	C4146	1
3**	MOTOR ADAPTER	B4396	1
3**	ADAPTER PLATE	B4397	1
5***	INPUT SHAFT ASSEMBLY - 16 INCH DRUM	B4758	1
5***	INPUT SHAFT ASSEMBLY - 24 INCH DRUM	B4759	1
6	MOTOR END PLATE	D2679	1
7	SEAL OIL CR VR2 TYPE	A8298	1
8	BEARING RADIAL BALL 3.5433 X 6.2992 X 1.1811	A8299	1
9	DRUM SHAFT	B4399	1
10***	REAR ANGLE - 16 INCH DRUM	C4081	1
10***	REAR ANGLE - 24 INCH DRUM	C3979	1
11***	FRONT ANGLE - 16 INCH DRUM	C4082	1
11***	FRONT ANGLE - 24 INCH DRUM	C3980	1
12***	DRUM - 16 INCH DIA.	D2754	1
12***	DRUM - 24 INCH DIA.	D2675	1
13****	REDUCER - MODEL TA2	C3939	1
13****	REDUCER - MODEL TA2H	C4341	1
14	REDUCER MOUNT	C3976	1
15	REDUCER SHAFT HOLDER	B4409	1
16	REDUCER END PLATE	D2677	1
17	SHAFT END CAP	A8380	1

\* Item is optional.

\*\* Item not shown.

\*\*\* Items 5, 10, 11 and 12 vary depending on the drum size of the winch.

\*\*\*\* Items vary depending on model.

**TA2 Series Assembly**

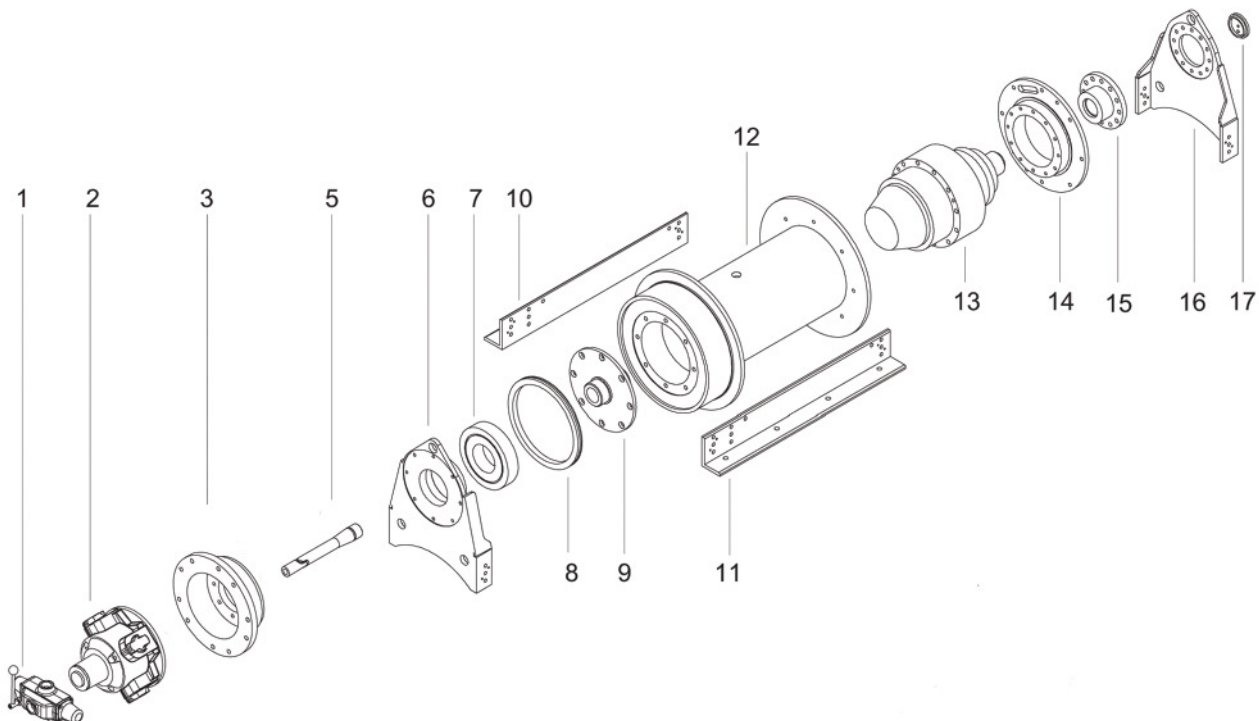

**TA2 SERIES - CONTROL VALVE**

**Part No. B4675**

item	description	part number	qty
1	END CAP GASKET	311-066	2
2	MATCHED SPOOL AND SLEEVE	321-913	1
4	SHOULDER SCREW 10 MM	817-002	1
5	CENTERING SHAFT GUIDE	311-071	1
6	SET SCREW M8 X 20	802-032	6
7	LEVER CAP	313-043	1
7*	SPEED ADJUSTING SCREW	815-036	1
7*	SEAL	808-093	1
7*	NUT	801-009	1
8	O RING 1-9/16X 1-11/16	808-010	6
9	VALVE BODY	321-060	1
10	VALVE SLEEVE SPACER	311-068	1
11	WASHER, SPRING CENTERING	311-072	1
12	SPRING 343720	814-015	1
13	END CAP - SPRING END	311-064	1
14	TOGGLE PIN	313-026	1
15	TOGGLE SHAFT	313-024	1
16	GRUB SCREW M8 X 10	815-010	1
17	CIRCLIP 20MM EXTERNAL	804-013	2
18	HAND LEVER PIVOT	313-008	1
19	GRUB SCREW M8 X 16	815-002	1
20	HEX BOLT M8 X 60	802-045	2
21	HAND LEVER	B4558	1
22	CAPSCREW HEXHD M10-1.5 X 35MM 8.8	A8282	1
23	PLUG 1/4 BSPT SQ. HEAD	816-061	3
24	VENT PLUG	113-050	1

\* Items not shown.

**TA2 Series Control Valve**

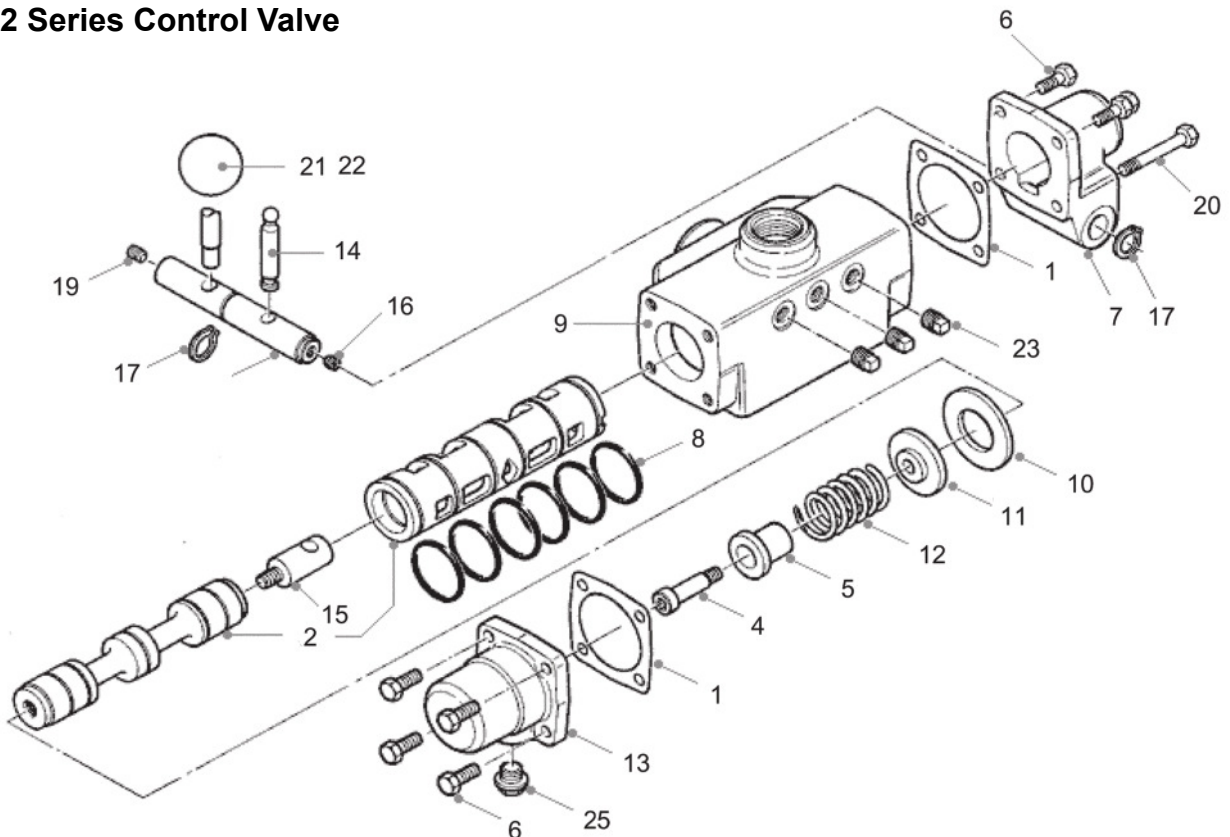

**TA2 SERIES - REMOTE CONTROL VALVE ASSEMBLY**

**Part No. B4580**

item	description	part number	qty
1	VALVE 1" NPT	B4675	1
2	O-RING 15MM X 20MM X 2.5MM	A11664	2
3	INPUT ADAPTER HCV TO RCV	A11663	1
4	SPRING RM310 RCV SPX 311-073	A11958	1

**TA2P Series Remote Control Valve Assembly**

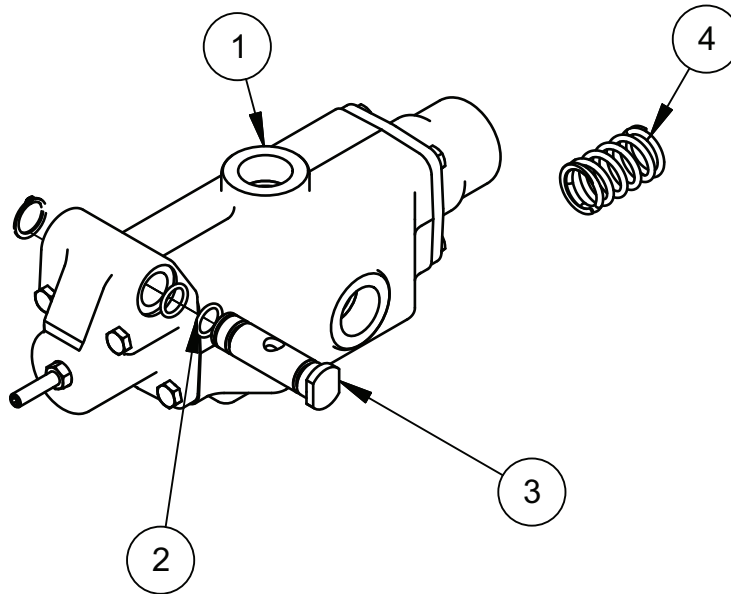

**This page intentionally left blank.**

## TA2 SERIES - PISTON AIR MOTOR

## Part No. C3937

item	description	part number	qty	kit no.
1	ROTARY VALVE BEARING (OUTER)	807-002	1	
2	ROTARY VALVE	330-059	1	
3	ROTARY VALVE HOUSING	330-011	1	
4	ROTARY VALVE BEARING (INNER)	807-001	1	
5	ROTARY VALVE BEARING CIRCLIP	804-054	1	
6	ROTARY VALVE HOUSING GASKET	-	-	339-911
7	CYLINDER GASKET	-	4	339-911
8	CYLINDER	310-082	4	
9	PISTON ASSEMBLY	330-902A	4	
10	COMPRESSION RING	-	4	339-911
11	OIL CONTROL RING	-	4	339-911
12	KING ROD	330-077	1	
13	CRANKSHAFT SPACER	330-013	2	
14	CRANKSHAFT CIRCLIP	804-012	1	
15A	CRANKSHAFT SPACER	310-036	1	
15B	CRANKSHAFT SPACER	310-037	5	
15C	CRANKSHAFT SPACER	310-038	1	
16	CRANKSHAFT SPACER SHIM	310-049	5	
18	CRANKSHAFT BEARING CIRCLIP	804-062	2	
19	OILSEAL	-	1	339-911
20	STD CRANKSHAFT ASSEMBLY	330-911	1	
24	STD FLANGE PLATE	330-076	1	
25	FLANGE PLATE SEAL	-	1	339-911
26	PLUG	816-071	1	
27	ENGINE CASE	330-012	1	
29	QUEEN ROD PIVOT	320-081	3	
30	QUEEN ROD	330-078	3	
31	CRANK SPACER	320-052	1	
32	CRANK SPACER	320-053	1	
34	CRANK SPACER	320-054	1	
35	BALANCE WEIGHT	330-010	1	
36	WOODRUFF KEY	811-010	1	
37	CYLINDER BOLTS	802-053	16	
38	VALVE HOUSING BOLTS	802-053	4	
40	ADAPTER PLATE BOLT	802-032	4	
41	EXHAUST COVER BOLTS	802-032	2	
45	SEAL (TRANSIT ONLY)	-	1	
46	BREATHER PLUG	130-066	1	
48	NEEDLE BEARING	807-065	1	
49	GRUB SCREW	815-002	1	
50	KEY	A8360	1	
51	ROTARY VALVE EXHAUST COVER	330-005	1	
52	COUNTERSUNK FLANGE BOLT	810-002	8	
55	OUTFIT SHAFT BRG (OUTER)	807-009	1	
56	OUTPUT SHAFT BRG (INNER)	807-009	1	
60	OIL LEVEL PLUG	816-063	2	
72	INLET ADAPTER PLATE	330-003	1	
73	INLET ADAPTOR PLATE GASKET	-	1	339-911
80	ROTARY VALVE SPACER	330-060	2	



### TA2 Series Motor Assembly

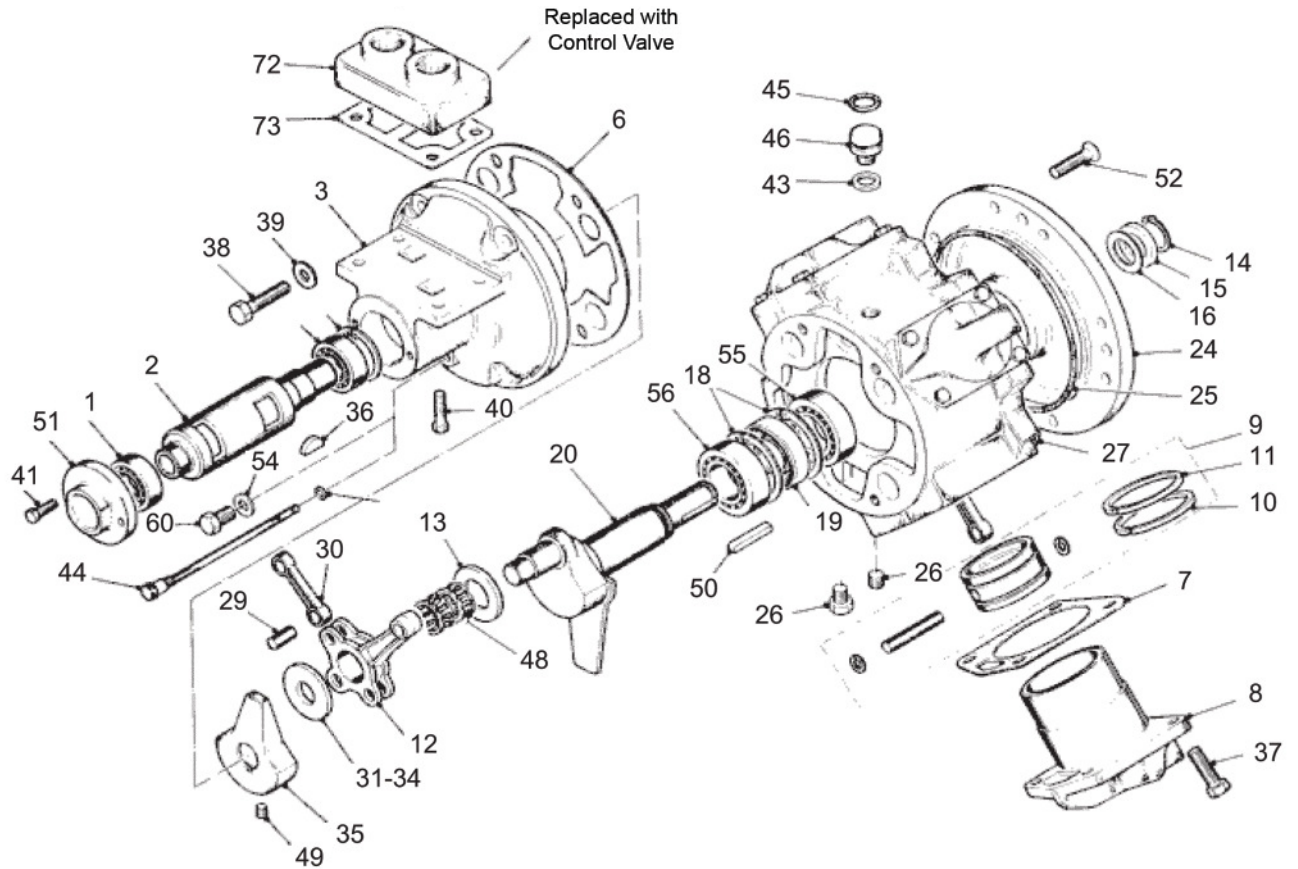

**TA2.5 SERIES - ASSEMBLY**

item	description	part number	qty
1	CONTROL VALVE MANUAL	B4675	1
1*	CONTROL VALVE FOR PENDANT	B4581	1
2	PISTON AIR MOTOR	C3989	1
3	MOTOR ADAPTER	C4331	1
3***	BRAKE 165 FT / LB	C4242	1
5**	INPUT SHAFT ASSEMBLY - 16 INCH DRUM	B4721	1
5**	INPUT SHAFT ASSEMBLY - 24 INCH DRUM	B4723	1
6	MOTOR END PLATE	D2679	1
7	SEAL OIL CR VR2 TYPE	A8298	1
8	BEARING RADIAL BALL 3.5433 X 6.2992 X 1.1811	A8299	1
9	DRUM SHAFT	B4399	1
10**	REAR ANGLE - 16 INCH DRUM	C4081	1
10**	REAR ANGLE - 24 INCH DRUM	C3979	1
11**	FRONT ANGLE - 16 INCH DRUM	C4082	1
11**	FRONT ANGLE - 24 INCH DRUM	C3980	1
12**	DRUM - 16 INCH DIA.	D2768	1
12**	DRUM - 24 INCH DIA.	D2686	1
13	REDUCER	C3982	1
14	REDUCER MOUNT	C3988	1
15	REDUCER SHAFT HOLDER	B4412	1
16	REDUCER END PLATE	D2687	1
17	SHAFT END CAP	A8389	1

\* Item is optional.

\*\* Items 5, 10, 11 and 12 vary depending on the drum size of the winch.

\*\*\* item not shown.

**TA2.5 Series Assembly**

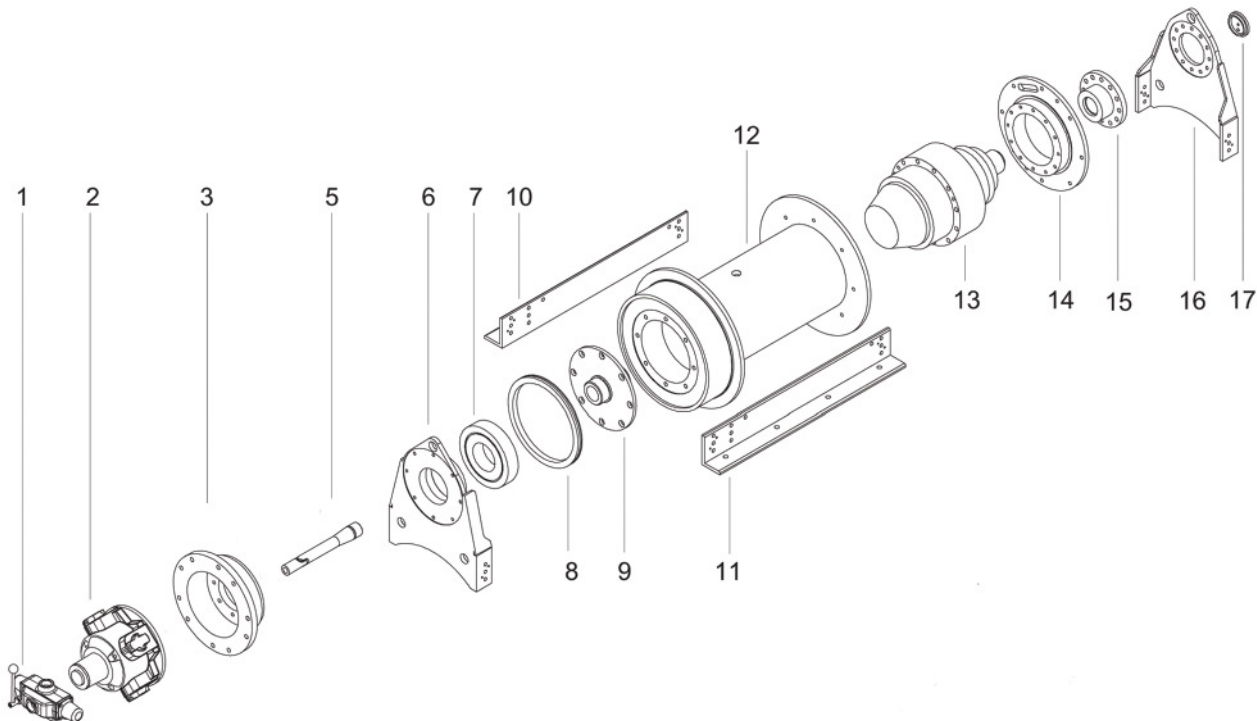

**TA5 SERIES - ASSEMBLY**

item	description	part number	qty
1	CONTROL VALVE MANUAL	B4676	1
1*	CONTROL VALVE FOR PENDANT	B4581	1
2	PISTON AIR MOTOR	C3989	1
3	MOTOR ADAPTER	C3962	1
3***	BRAKE 165 FT / LB	C4243	1
5**	INPUT SHAFT ASSEMBLY - 16 INCH DRUM	B4722	1
5**	INPUT SHAFT ASSEMBLY - 24 INCH DRUM	B4725	1
5**	INPUT SHAFT ASSEMBLY - 30 INCH DRUM	B4727	1
6	MOTOR END PLATE	D2694	1
7	SEAL OIL CR VR2 TYPE	A8470	1
8	BEARING RADIAL BALL 3.5433 X 6.2992 X 1.1811	A8474	1
9	DRUM SHAFT	C3992	1
10**	REAR ANGLE - 16 INCH DRUM	D2835	1
10**	REAR ANGLE - 24 INCH DRUM	D2827	1
10**	REAR ANGLE - 30 INCH DRUM	D2712	1
11**	FRONT ANGLE - 16 INCH DRUM	D2844	1
11**	FRONT ANGLE - 24 INCH DRUM	D2828	1
11**	FRONT ANGLE - 30 INCH DRUM	D2713	1
12**	DRUM - 16 INCH DIA.	D2840	1
12**	DRUM - 24 INCH DIA.	D2632	1
12**	DRUM - 30 INCH DIA.	D2695	1
13	REDUCER	C3983	1
14	REDUCER MOUNT	D2692	1
15	REDUCER SHAFT HOLDER	B4415	1
16	REDUCER END PLATE	D2693	1
17	SHAFT END CAP	A8405	1

\* Item is optional.

\*\* Items 5, 10, 11 and 12 vary depending on the drum size of the winch.

\*\*\* Item not shown.

**TA5 Series Assembly**

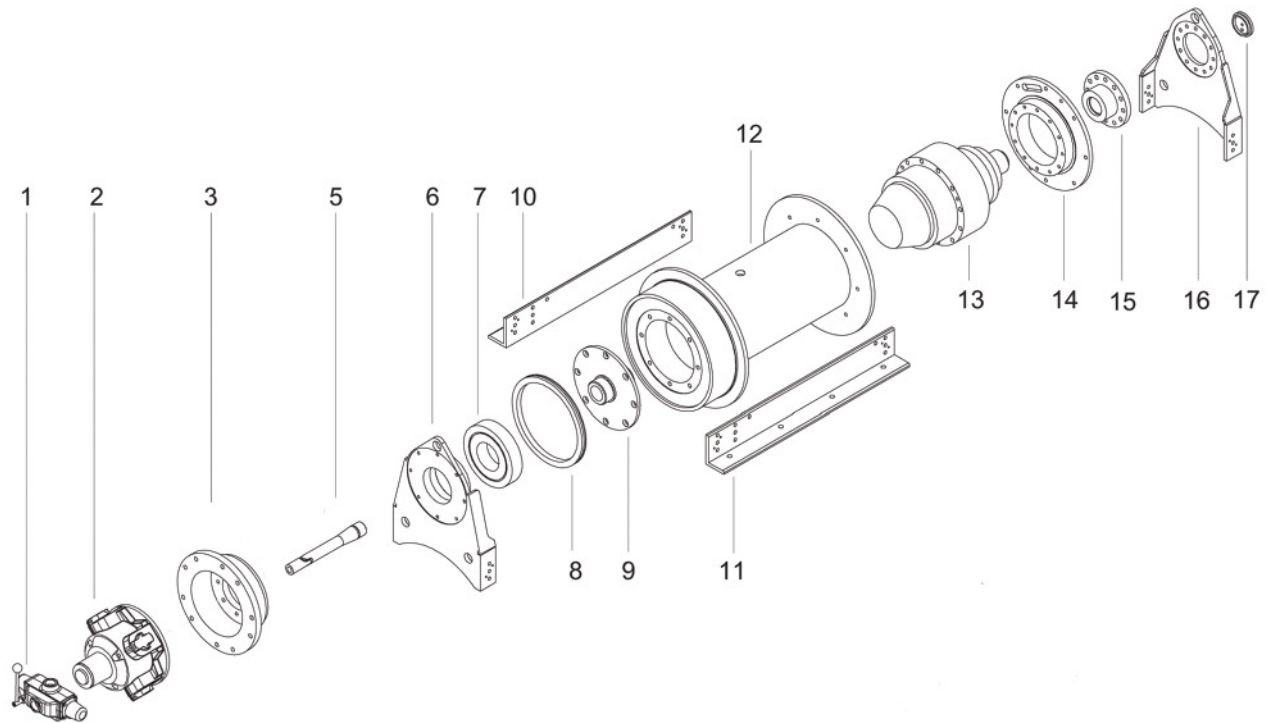

**TA7 SERIES - ASSEMBLY**

item	description	part number	qty
1	CONTROL VALVE MANUAL	B4676	1
1*	CONTROL VALVE FOR PENDANT	B4581	1
2	PISTON AIR MOTOR	C3989	1
3	MOTOR ADAPTER	C3962	1
3***	BRAKE 165 FT / LB	C4243	1
5**	INPUT SHAFT ASSEMBLY - 24 INCH DRUM	B4724	1
5**	INPUT SHAFT ASSEMBLY - 30 INCH DRUM	B4726	1
5**	INPUT SHAFT ASSEMBLY - 36 INCH DRUM	B4728	1
6	MOTOR END PLATE	D2699	1
7	SEAL OIL CR VR2 TYPE	A8470	1
8	BEARING RADIAL BALL 3.5433 X 6.2992 X 1.1811	A8478	1
9	DRUM SHAFT	C3993	1
10**	REAR ANGLE - 24 INCH DRUM	D2851	1
10**	REAR ANGLE - 30 INCH DRUM	D2843	1
10**	REAR ANGLE - 36 INCH DRUM	D2714	1
11**	FRONT ANGLE - 24 INCH DRUM	D2852	1
11**	FRONT ANGLE - 30 INCH DRUM	D2844	1
11**	FRONT ANGLE - 36 INCH DRUM	D2715	1
12**	DRUM - 24 INCH DIA.	D2855	1
12**	DRUM - 30 INCH DIA.	D2847	1
12**	DRUM - 36 INCH DIA.	D2697	1
13	REDUCER	D2683	1
14	REDUCER MOUNT	D2696	1
15	REDUCER SHAFT HOLDER	B4416	1
16	REDUCER END PLATE	D2698	1
17	SHAFT END CAP	A8406	1

\* Item is optional.

\*\* Items 5, 10, 11 and 12 vary depending on the drum size of the winch.

\*\*\* Item not shown.

**TA7 Series Assembly**

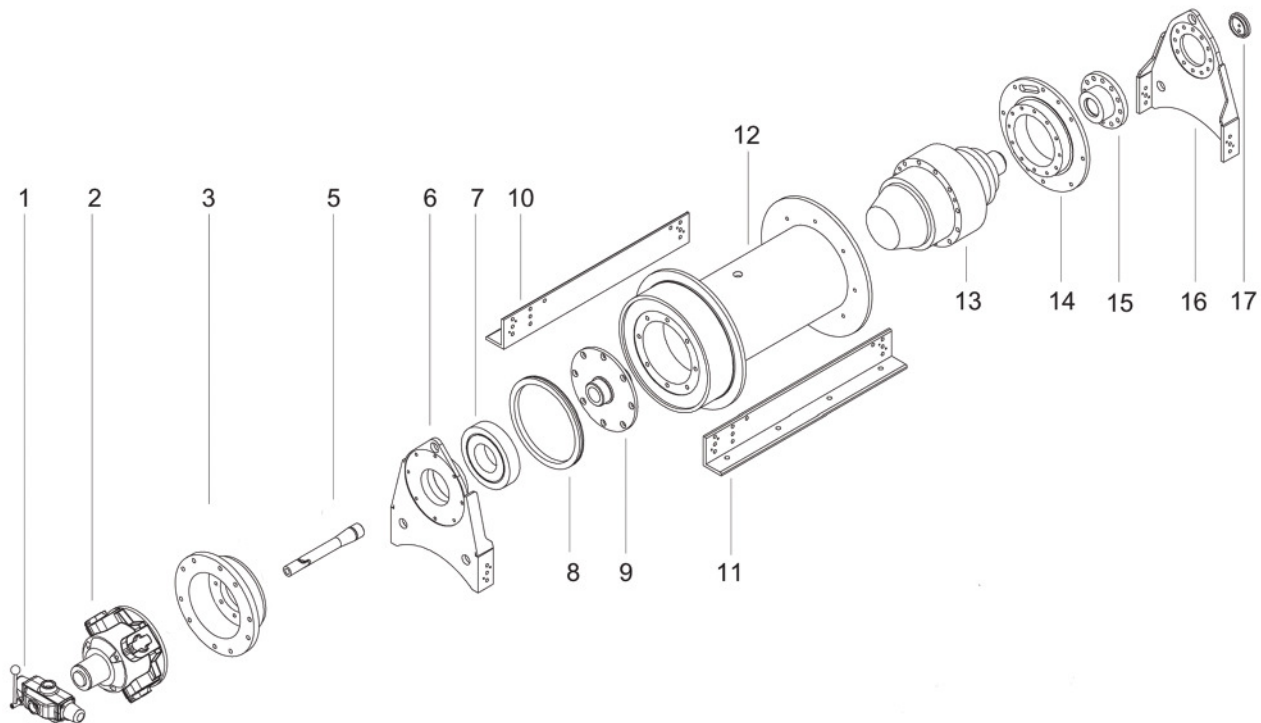

**TA2.5 / TA5 / TA7 SERIES - CONTROL VALVE**

**Part No. B4676**

item	description	part number	qty
1	END CAP GASKET	521-066	2
2	MATCHED SPOOL AND SLEEVE	521-913	1
4	SHOULDER SCREW 10 MM	817-002	1
5	CENTERING SHAFT GUIDE	521-071	1
6	SET SCREW M8 X 20	802-032	6
7	LEVER CAP	523-043	1
7*	SPEED ADJUSTING SCREW	815-036	1
7*	SEAL	808-093	1
7*	NUT	801-009	1
8	O RING 2 X 2 1/8	808-013	6
9	VALVE BODY	521-060	1
10	VALVE SLEEVE SPACER	521-068	1
11	WASHER, SPRING CENTERING	521-072	1
12	SPRING FLEXO 403824	814-020	1
13	END CAP - SPRING END	521-064	1
14	VENT PLUG	113-050	1
15	PLUG 1/4 BSPT SQ. HEAD	816-061	3
16	TOGGLE SHAFT	523-024	1
17	TOGGLE PIN	A9370	1
18	HAND LEVER PIVOT	B4795	1
19	HAND LEVER	B4558	1
20	CAPSCREW HEXHD M10-1.5 X 35MM 8.8	A8282	
21	CIRCLIP 20MM EXTERNAL	804-013	2
22	GRUB SCREW M8 X 10	815-010	1
23	GRUB SCREW M8 X 16	815-002	1

\* Item not shown.

**TA2.5 / TA5 / TA7 Series Control Valve**

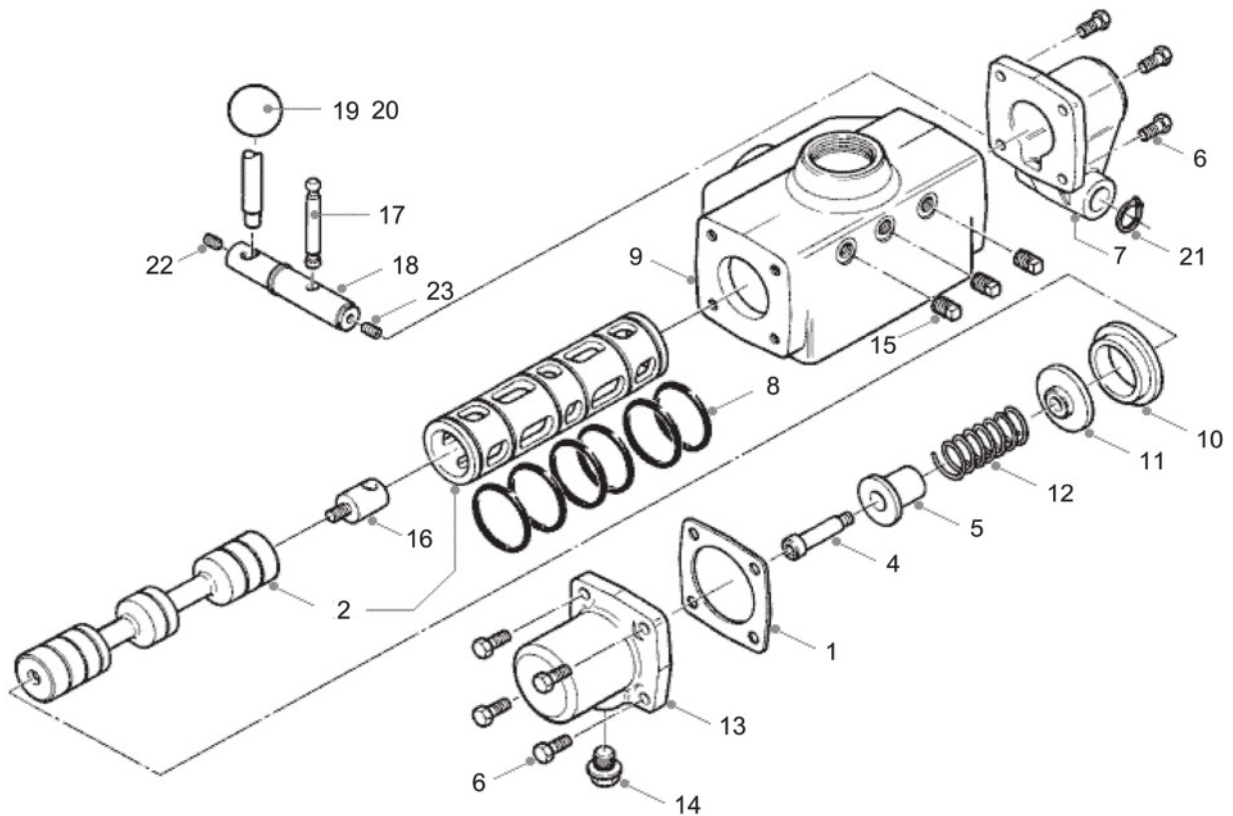

**TA2.5/TA5/TA7 SERIES - REMOTE CONTROL VALVE ASSEMBLY**

**Part No. B4581**

item	description	part number	qty
1	VALVE	B4676	1
2	O-RING 15MM X 20MM X 2.5MM	A11664	2
3	INPUT ADAPTER HCV TO RCV	A11663	1
4	SPRING RM510/610 RCV SPX 814-019	A11662	1

**TA2.5/TA5/TA7 Series Remote Control Valve Assembly**

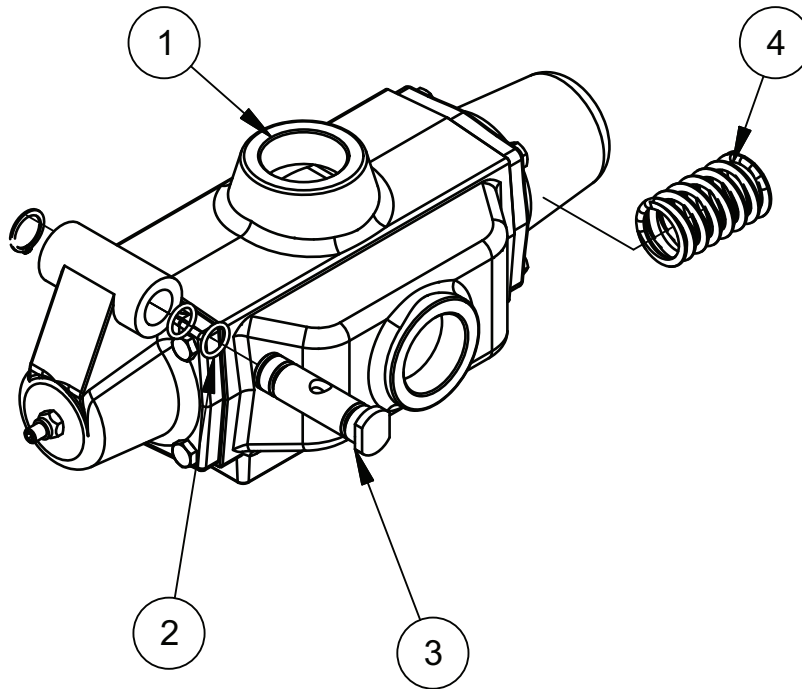

**This page intentionally left blank.**

**TA2.5 / TA5 / TA7 SERIES - PISTON AIR MOTOR****Part No. C3989 and C4306**

item	description	part number	qty	kit no.
1	ROTARY VALVE BEARING (OUTER)	807-006	1	
2	ROTARY VALVE	520-006	1	
3	ROTARY VALVE HOUSING	520-011	1	
4	ROTARY VALVE BEARING (INNER)	807-005	1	
5	ROTARY VALVE BEARING CIRCLIP	804-066	1	
6	ROTARY VALVE HOUSING GASKET	-	1	529-911
7	CYLINDER GASKET	-	5	529-911
8	CYLINDER	510-082	5	
9	PISTON ASSEMBLY	520-902A	5	
10	COMPRESSION RING	-	5	529-911
11	OIL CONTROL RING	-	5	529-911
12	KING ROD	520-077	1	530-950*
13	CRANKSHAFT SPACER	520-052	2	
17	CRANKSHAFT BEARING	807-062	2	
19	CRANKSHAFT OILSEAL	-	1	529-911
20	STD CRANKSHAFT ASSEMBLY	520-901	1	
21	CRANK BOLT	510-088	1	
22	CRANK NUT	801-009	1	
23	SPRING DOWEL	806-013	2	
24	STD FLANGE PLATE	520-076	1	
26	PLUG	816-071	1	
27	ENGINE CASE	520-012	1	
28	ENGINE CASE GASKET	-	1	529-911
29	QUEEN ROD PIVOT	520-081	4	530-950*
30	QUEEN ROD	520-078	4	530-950*
37	CYLINDER BOLTS	802-074	20	
38	VALVE HOUSING BOLTS	802-073	5	
39	WASHER (FOR ITEM 38)	803-015	5	
40	ADAPTER PLATER BOLT	802-054	4	
41	EXHAUST COVER BOLTS	802-033	4	
42	FLANGE PLATE PLUGS	815-008	5	
45	SEAL (TRANSIT ONLY)	808-004	1	
46	BREATHER PLUG	130-066	1	
48	NEEDLE BEARING	807-047	1	
51	ROTARY VALVE EXHAUST COVER	520-005	1	
57	FLANGE PLATE CAP SCREWS	809-001	10	
61	DRIVE PIN (DIA 10MM)	806-001	1	
62	DRIVE PIN (DIA 12 MM)	806-002	1	
72	INLET ADAPTER PLATE	520-003	1	
73	INLET ADAPTOR PLATE GASKET	-	1	529-911
	RM510 SEAL KIT	529-911		
*	RM510 CONVERSION KIT	530-950	1	

**TA2.5 / TA5 / TA7 SERIES - PISTON AIR MOTOR****Part No. C3989**

item	description	part number	qty	kit no.
18	CRANKSHAFT BEARING CIRCLIP	804-068	2	
50	KEY	811-030	1	
55	OUTPUT SHAFT BRG (OUTER)	807-063	1	
56	OUTPUT SHAFT BRG (INNER)	807-012	1	
58	OUTPUT HOUSING BOLTS	809-002	5	
59	OUTPUT HOUSING COVER BOLTS	802-016	5	
63	OUTPUT SHAFT BEARING SPACER	518-001	1	
64	OUTPUT SHAFT SPRING RING	518-004	1	
65	OUTPUT SHAFT CIRCLIP	804-017	1	
66	OUTPUT SHAFT SEAL	-	1	529-911
67	OUTPUT SHAFT	518-003	1	
68	OUTPUT SHAFT HOUSING	518-005	1	
69	OUTPUT SHAFT OILSEAL	808-042	1	
70	OUTPUT SHAFT HOUSING COVER	518-002	1	
71	OUTPUT SHAFT GREASE NIPPLE	816-015	1	



**TA2.5 / TA5 / TA7 Series Motor Assembly  
for C3989 and C4306**

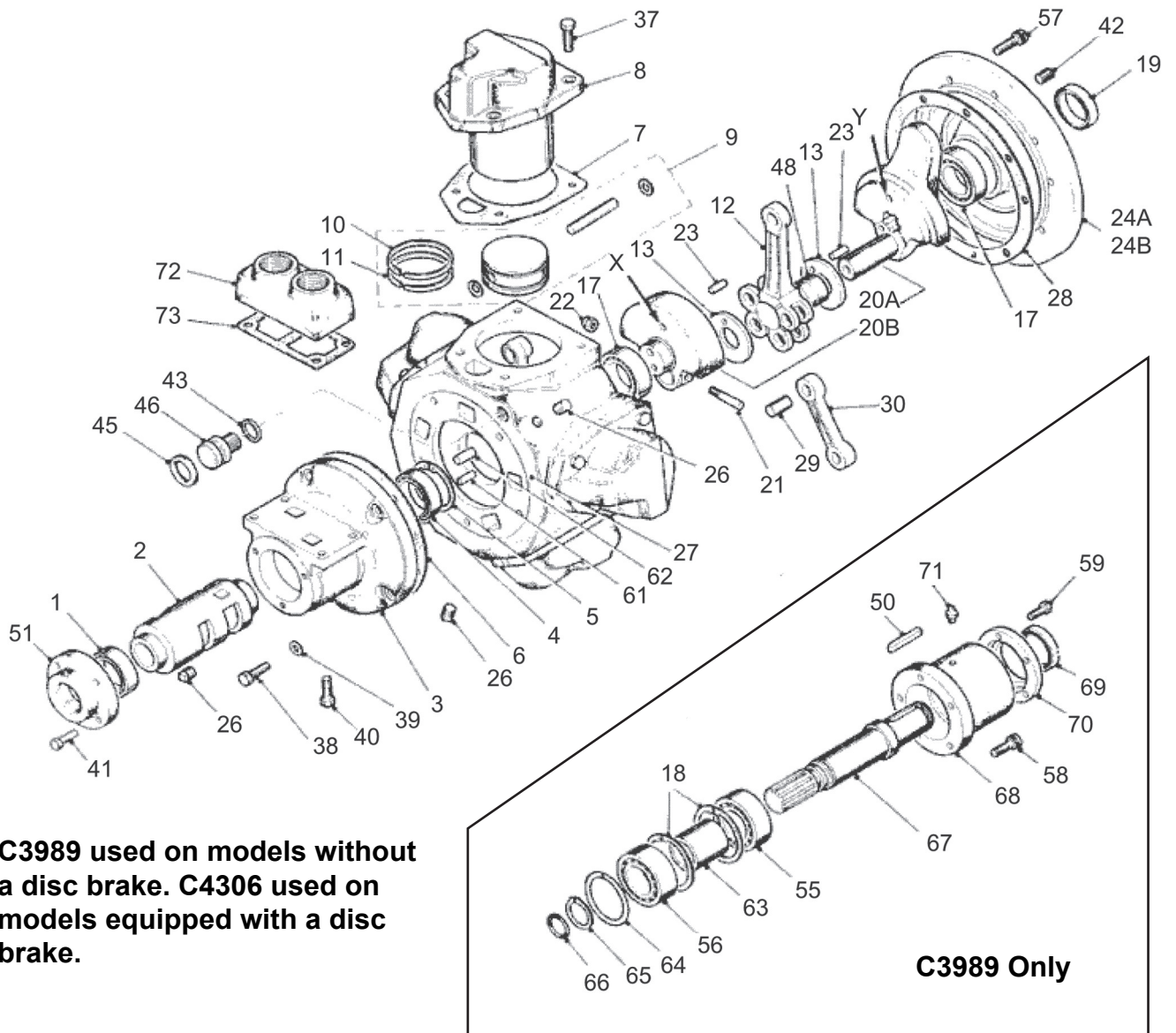

**C3989 used on models without a disc brake. C4306 used on models equipped with a disc brake.**

**C3989 Only**

BIG RED TA Series UTILITY RATED Air Winch Performance Characteristics

	TA2 Series		TA2H Series		TA2.5 Series		TA5 Series		TA7 Series	
	Standard	Metric	Standard	Metric	Standard	Metric	Standard	Metric	Standard	Metric
Load Rating 1st Layer	7,200 lb	3,265 kg	3,600 lb	1,632 kg	7,200 lb	3,265 kg	18,000 lb	8,164 kg	23,600 lb	10,704 kg
Load Rating Mid-Drum	5,700 lb	2,585 kg	2,900 lb	1,315 kg	5,900 lb	2,676 kg	14,000 lb	6,350 kg	19,000 lb	8,618 kg
Load Rating Full Drum	4,700 lb	2,131 kg	2,400 lb	1,088 kg	5,000 lb	2,268 kg	11,500 lb	5,216 kg	15,900 lb	7,212 kg
Line Speed 1st Layer*	30 fpm	9.1 m/min	61 fpm	18.6 m/min	79 fpm**	24.1 m/min**	30 fpm**	9.1 m/min**	19 fpm	5.8 m/min
Line Speed Mid-Drum*	38 fpm	11.6 m/min	77 fpm	23.5 m/min	96 fpm**	29.3 m/min**	39 fpm**	11.9 m/min**	24 fpm	7.3 m/min
Line Speed Full Drum*	46 fpm	14.0 m/min	94 fpm	28.7 m/min	114 fpm**	34.7 m/min**	47 fpm**	14.3 m/min**	29 fpm	8.8 m/min
Input HP	7.1 hp	7.1 hp	7.1 hp	7.1 hp	18.3 hp	18.3 hp	17.8 hp	17.8 hp	14.4 hp	14.4 hp
Max. Stall Pull 1st Layer	9,000 lb	4,082 kg	4,500 lb***	2,041kg***	11,000 lb	4,989 kg	33,000 lb	14,968 kg	38,000 lb	17,236 kg
Pressure	90 psi	6.3 kgf/cm2	90 psi	6.3 kgf/cm2	90 psi	6.3 kgf/cm2	90 psi	6.3 kgf/cm2	90 psi	6.3 kgf/cm2
Flow	250 scfm	1,770 m3/min	250 scfm	1,770 m3/min	600 scfm	4,247 m3/min	550 scfm	3,893 m3/min	550 scfm	3,893 m3/min
Pipe Inlet Size	1 in	25.4 mm	1 in	25.4 mm	1.5 in	38.1 mm	1.5 in	38.1 mm	1.5 in	38.1 mm
Hose Size	1.25 in	31.8 mm	1.25 in	31.8 mm	1.5 in	38.1 mm	1.5 in	38.1 mm	1.5 in	38.1 mm
Minimum Design Temp	(-4°)F	(-20°)C	(-4°)F	(-20°)C	(-4°)F	(-20°)C	(-4°)F	(-20°)C	(-4°)F	(-20°)C

\* Line speeds vary based on conditions of air supply.

\*\* ABS certifications may specify slower line speeds than those published due to variances in air flow at time of actual test.

\*\*\* Estimated Value.

BIG RED TA Series UTILITY RATED Air Winch Drum Capacities\*

Drum Width	Rope Diameter	Breaking Strength**	16 in (407 mm)			24 in (610 mm)			30 in (762 mm)			36 in (915 mm)		
			1st Layer	Mid Drum	Full Drum	1st Layer	Mid Drum	Full Drum	1st Layer	Mid Drum	Full Drum	1st Layer	Mid Drum	Full Drum
	(in) (mm)	(lb) (kg)	(ft) (m)	(ft) (m)	(ft) (m)	(ft) (m)	(ft) (m)	(ft) (m)	(ft) (m)	(ft) (m)	(ft) (m)	(ft) (m)	(ft) (m)	(ft) (m)
TA2 Series	0.5 12.7	26,600 12,065	83 25	380 115	850 259	130 39	570 173	1,270 387	- -	- -	- -	- -	- -	- -
TA2H Series	0.5 12.7	26,600 12,065	83 25	380 115	850 259	130 39	570 173	1,270 387	- -	- -	- -	- -	- -	- -
TA2.5 Series	0.63 16.0	41,200 18,688	71 21	260 79	580 176	110 33	390 118	860 262	- -	- -	- -	- -	- -	- -
TA5 Series	0.75 19.1	58,800 26,671	72 21	360 109	810 246	120 36	550 167	1,210 368	150 45	680 207	1,520 463	- -	- -	- -
TA7 Series	0.88 22.4	79,600 36,106	- -	- -	- -	120 36	520 158	1,150 350	160 48	650 198	1,440 438	190 57	780 237	1,730 527

\* Drum capacity is based on 0.5 inch flange clearance at top layer per ASME B30.7.

\*\* Values based on 6x37 IWRC EIPS wire rope.

Series	Drum Diameter		Flange Diameter		Drum Width		Fleet Angle Dist.	
	(in)	(mm)	(in)	(mm)	(in)	(mm)	(in)	(mm)
TA2-16	11.50	292	20.00	508	16.00	406	26	8
TA2-24	11.50	292	20.00	508	24.00	610	39	12
TA2H-16	11.50	292	20.00	508	16.00	406	26	8
TA2H-24	11.50	292	20.00	508	24.00	610	39	12
TA2.5-16	12.75	324	21.00	533	16.00	406	26	8
TA2.5-24	12.75	324	21.00	533	24.00	610	39	12
TA5-16	16.00	406	28.00	711	16.00	406	26	8
TA5-24	16.00	406	28.00	711	24.00	610	39	12
TA5-30	16.00	406	28.00	711	30.00	762	48	15
TA7-24	20.00	508	33.00	838	24.00	610	39	12
TA7-30	20.00	508	33.00	838	30.00	762	48	15
TA7-36	20.00	508	33.00	838	36.00	914	58	18

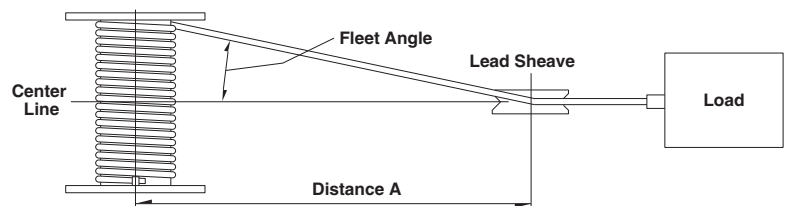

**This page intentionally left blank.**



**Thern, Incorporated**  
5712 Industrial Park Road  
Winona, MN 55987

PH 507-454-2996  
FAX 507-454-5282

EMAIL: [info@thern.com](mailto:info@thern.com)  
[www.thern.com](http://www.thern.com)

**Thern Europe**  
Windmolen 22  
7609 NN Almelo  
Netherlands

PH +31-548-659-052

EMAIL: [europe@therneurope.eu](mailto:europe@therneurope.eu)