

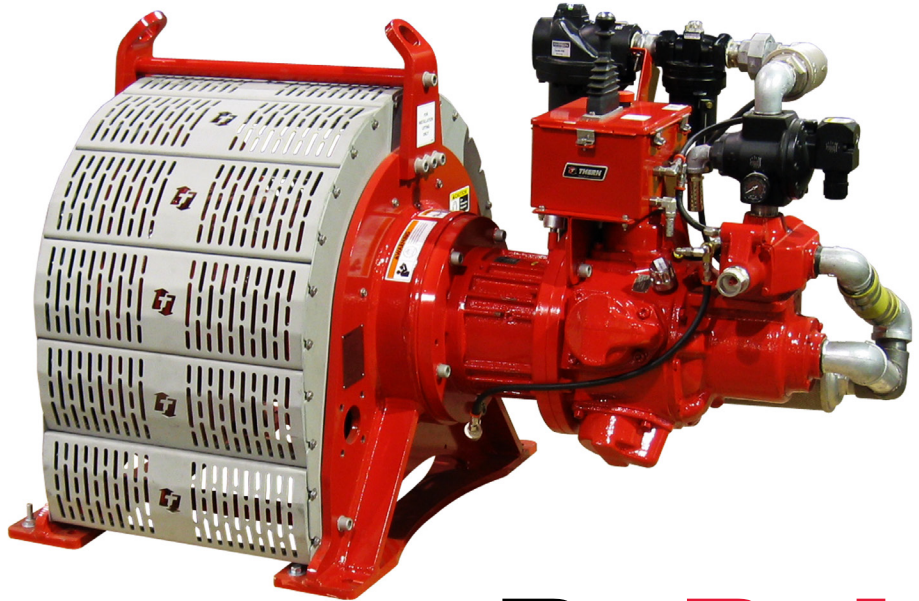

Read this Owner's Manual thoroughly before operating the equipment. Keep it with the equipment at all times. Replacements are available from Thern, Inc., PO Box 347, Winona, MN 55987, 507-454-2996. [www.thern.com](http://www.thern.com)

**IMPORTANT:** Please record product information on page 2. This information is required when calling the factory for service.

ORIGINAL TEXT



**Big Red**

# Owner's Manual

## For TAC Series Planetary Gear Air Winches

## Warranty Statement

Please record the following:

Date Purchased: \_\_\_\_\_

Model No.: \_\_\_\_\_

Serial No.: \_\_\_\_\_

This information is required when calling the factory for service.

Thern, Inc. warrants each new products to be free from defects in material and workmanship under normal use and service for a period of 24 months from the date of purchase by the original using buyer. Genuine Thern, Inc. replacement parts and components will be warranted for 30 days from the date of purchase, or the remainder of the original equipment warranty period, whichever is longer.

Under no circumstances will this warranty cover a product or component thereof, which, in the opinion of the company, has been subjected to misuse, unauthorized modifications, alteration, an accident or shipping damage. This warranty also shall not apply to products that are operated improperly, improperly maintained or improperly stored.

This warranty does not cover any costs for removal of our product, downtime, or any other incidental or consequential costs or damages resulting from the claimed defects. Brake discs, wire rope or other wear components are not covered under this warranty, as their life is subject to use conditions which vary between applications. Any alteration, repair or modification of the product outside the Thern, Inc. factory shall void this warranty.

Thern, Inc. in no way warrants pneumatic, hydraulic or electric motors and control valves or other trade accessories since these items are warranted separately by their respective manufacturers.

FACTORY AUTHORIZED REPAIR OR REPLACEMENT AS PROVIDED UNDER THIS WARRANTY IS THE EXCLUSIVE REMEDY TO THE CONSUMER. THERN, INC. SHALL NOT BE LIABLE FOR ANY INCIDENTAL OR CONSEQUENTIAL DAMAGES FOR BREACH OF ANY EXPRESS OR IMPLIED WARRANTY ON THIS PRODUCT. EXCEPT TO THE EXTENT PROHIBITED BY APPLICABLE LAW, ANY IMPLIED WARRANTY OF MERCHANTABILITY OR FITNESS FOR A PARTICULAR PURPOSE ON THIS PRODUCT IS LIMITED IN DURATION TO THE DURATION OF THIS WARRANTY.

Some states do not allow the exclusion or limitation of incidental or consequential damages, or allow limitations on how long an implied warranty lasts, so the above limitation or exclusion may not apply to you. This warranty gives you specific legal rights, and you may also have other rights which vary from state to state.

**To make a claim under this warranty, contact the factory for an RGA number. The product must be returned, prepaid, directly to Thern, Inc. or to an authorized service center. A completed warranty claim form must accompany the product. If the product is found to be defective, it will be repaired or replaced free of charge, and Thern, Inc. will reimburse the shipping costs.**

**Note: Thern, Inc. reserves the right to change the design or discontinue the production of any product without prior notice.**

## About This Manual

The Occupational Safety and Health Act of 1970 states that it is the employer's responsibility to provide a workplace free of hazard. To this end, all equipment should be installed, operated, and maintained in compliance with applicable trade, industrial, federal, state, and local regulations. It is the equipment owner's responsibility to obtain copies of these regulations and to determine the suitability of the equipment to its intended use.

This Owner's Manual, and warning labels attached to the equipment, are to serve as guidelines for hazard-free installation, operation, and maintenance. They should not be understood to prepare you for every possible situation.

The information contained in this manual is applicable only to the Thern TAC Series Planetary Gear Air Winches. Do not use this manual as a source of information for any other equipment.

The following symbols are used for emphasis throughout this manual:

### **▲WARNING**

Failure to follow 'WARNING!' instructions may result in equipment damage, property damage, and/or serious personal injury.



### **▲CAUTION**

Failure to follow 'CAUTION!' instructions may result in equipment damage, property damage, and/or minor personal injury.

Important!

Failure to follow 'important!' instructions may result in poor performance of the equipment.

Figure 1a – Serial Tag

		5712 INDUSTRIAL PK RD WINONA, MN 55987 USA (507) 454-2996	
MODEL #	<input type="text"/>		
SERIAL #	<input type="text"/>		
DATE OF MANUFACTURE	<input type="text"/>		
MINIMUM DESIGN TEMPERATURE DEG C (F)	<input type="text"/>		
1ST LAYER RATING KG (LBS)	<input type="text"/>		
FULL DRUM RATING KG (LBS)	<input type="text"/>		
1ST LAYER SPEED MPM (FPM)	<input type="text"/>		
FULL DRUM SPEED MPM (FPM)	<input type="text"/>		
AIR FLOW RATE CPM (SCFM)	<input type="text"/>		
AIR PRESSURE BAR (PSIG)	<input type="text"/>		
DRUM SIZE MM	ID <input type="text"/>	OD <input type="text"/>	W <input type="text"/>
DRUM SIZE INCH	ID <input type="text"/>	OD <input type="text"/>	W <input type="text"/>
ROPE SIZE MM (INCH)	<input type="text"/>		
MAXIMUM NUMBER OF ROPE LAYERS	<input type="text"/>		
AUTHORIZED REPRESENTATIVE:	EuroDev B.V. Windmolen 22 7609 NN Almelo The Netherlands		
NV D-####			
PART # A11151			

*number for winch units with DNV certification (if applicable)* →

→ *CE mark for units with CE certification (if applicable)*

→ *authorized dealer information*

Figure 1b - Serial Tag Location

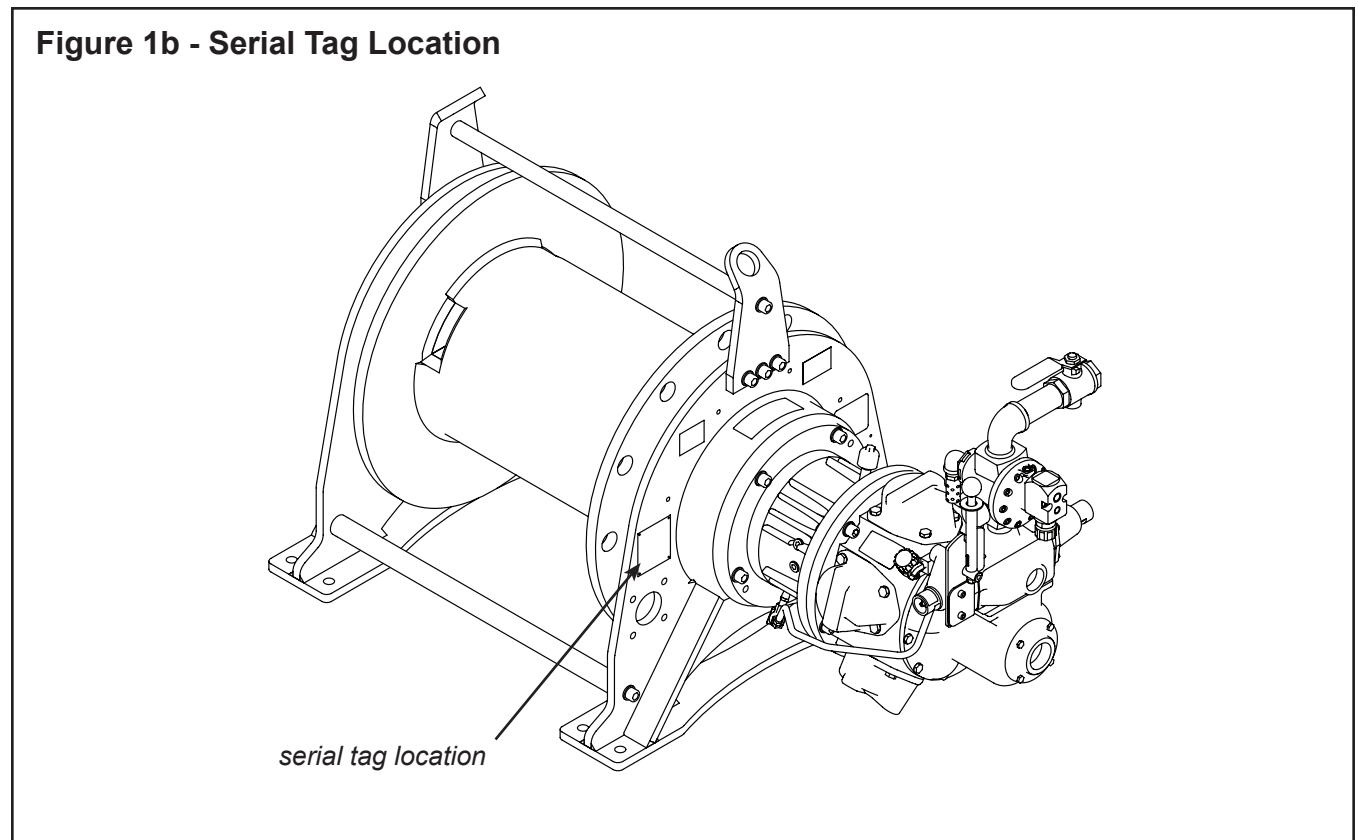

## Suggestions for Safe Operation

### **⚠WARNING**

#### **DO the following:**

Read and comply with the guidelines set forth in this Owner's Manual. Keep this and all labels attached to the winch, readable and with the equipment at all times. Contact Thern, Inc. for replacements.

Check lubrication before use.

Install the wire rope securely to the winch drum.

Keep at least 5 wraps of wire rope wound on the drum at all times, to serve as anchor wraps. With less than 5 wraps on the drum the wire rope could come loose, causing the load to escape.

Keep hands away from the drum, gears, wire rope, and other moving parts of the equipment.

Ensure brake holds prior to making complete lift by lifting load a short distance and releasing control.

If there is slack wire rope condition, the hoisting mechanisms shall be inspected to ensure all wire ropes are properly seated on drums and in sheaves, before resuming winch operation.

Depressurize and disconnect air supply before servicing the equipment.



---

## Suggestions for Safe Operation

**⚠WARNING****DO NOT do the following:**

**Do not lift loads over people. Do not walk or work under a load or in the line of force of any load.**

**Do not exceed the load rating of the winch or any other component in the system. To do so could result in failure of the equipment.**

**Do not use more than one winch to move a load unless each winch was designed for use in a multiple winch system.**

**Do not use damaged or malfunctioning equipment. To do so could result in failure of the equipment.**

**Do not modify the equipment in any way. To do so could cause equipment failure.**

**Do not wrap the wire rope around the load. This damages the wire rope and could cause the load to escape. Use a sling or other approved lifting device.**

**Do not operate the winch with drive guards or gear covers removed or improperly installed.**

**Do not divert your attention from the operation. Stay alert to the possibility of accidents, and try to prevent them from happening.**

**Do not jerk or swing the load. Avoid shock loads by starting and stopping the load smoothly. Shock loads overload the equipment and may cause damage.**

**Do not leave a suspended load unattended unless specific precautions have been taken to secure the load and keep people away from the winch and out from under the load.**

## 1.1 Installing the Winch

### Important!

- Inspect the winch immediately following installation according to the Instructions for Periodic Inspection. This will give you a record of the condition of the winch with which to compare future inspections.
- A qualified professional should inspect or design the foundation to insure that it will provide adequate support.
- Locate the winch so it will be visible during the entire operation.
- When moving and positioning the winch, lift using the lifting eyes in the frame or with a sling wrapped around drum.
- Do not weld the winch frame to the foundation or support structure. Welding the frame may void warranty, contact Thern, Inc. Use fasteners as instructed.

### **▲WARNING**

**All supporting structure, mounting hardware and attaching hardware must be in accordance with all applicable standards codes and regulations.**

**Ensure proper selection and installation of wire rope and sheaves. Sheaves and sheave mounting must be designed and selected in accordance with all applicable standards, codes, and regulations. Improper installation of wire rope or sheave can cause uneven spooling and wire rope damage that could cause a load to escape.**

**Do not install the winch in an area defined as hazardous by the National Electric Code, unless installation in such an area has been thoroughly approved.**

**Do not install the winch near corrosive chemicals, flammable materials, explosives, or other elements that may damage the winch or injure the operator. Adequately protect the winch and the operator from such elements.**

**Position the winch so the operator can stand clear of the load, and out of the path of a broken wire rope that could snap back and cause injury.**

**Attach the winch to a rigid and level foundation that will support the winch and its load under all load conditions, including shock loading.**

- 1.1.1 CONSULT APPLICABLE CODES AND REGULATIONS for specific rules on installing the equipment.
- 1.1.2 LOCATE THE WINCH in an area clear of traffic and other obstacles. Make sure the winch is accessible for maintenance and operation.
- 1.1.3 LOCATE THE WINCH in an area with adequate ambient temperatures per the serial tag rating. Refer to Figure 1b for serial tag location.
- 1.1.4 USE LIFTING EYES to properly locate winch during installation. See section 4.1 - Transporting the Winch.
- 1.1.5 INSTALL THE WINCH on a horizontal surface. The winch is designed and assembled for horizontal base mounting. Special consideration must be taken if mounting vertically or upside-down. Please contact Thern, Inc.
- 1.1.6 CONSIDER ergonomic impact of the winch's height on manual operation. To help prevent operator injury due to stretching/reaching, consider placing a riser or other means or adjusting the height of the winch.
- 1.1.7 MAINTAIN A FLEET ANGLE between 1/2 and 1-1/2 degrees. The proper fleet angle minimizes wire rope damage by helping the wire rope wind uniformly onto the drum. See Figure 2.

- 1.1.8 FASTEN THE WINCH SECURELY to the foundation.
- a FOR STANDARD PRODUCTS referred to in this manual, use coarse thread fasteners, grade ISO 8.8 (or ANSI 5) or better. Be sure to check the torque required for your fastener selection before mounting winch. Make sure the winch is secured to a solid foundation able to support the winch and the load under all conditions with design factors based on accepted engineering practices.
  - b NON-STANDARD PRODUCTS that vary from the original design may have different fastening requirements. Contact a structural engineer or Thern, Inc. for this information.

CONTACT A QUALIFIED PROFESSIONAL FOR MOUNTING INSTRUCTIONS TO COMPLY WITH LOCAL CODES.

**Important!**

- Use a sheave or roller guide to direct the wire rope to the drum whenever possible.
- Install sheaves, tracks and other equipment so they will remain fixed under all load conditions. Follow the recommendations of the equipment manufacturer.
- Use sheaves of proper diameter to minimize wear on the wire rope. Follow the recommendations of the sheave manufacturer.

**Figure 2 – Maintaining the Fleet Angle**

- **When wire rope travels over a sheave or through a roller guide – maintain fleet angle by locating the sheave or guide an appropriate distance from the drum, shown as distance “A”.**

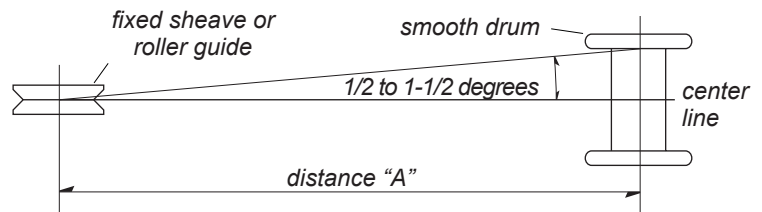

- **When wire rope travels directly to the load – maintain fleet angle by controlling side-to-side movement of the load with tracks or guide rails. Allowing the load to move too far to one side causes stress on the drum flange which may cause damage.**

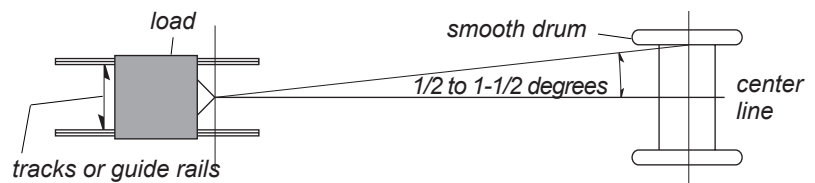

## 1.2 Installing the Breather Plugs

**Figure 3 – Installing the Breather Plugs**

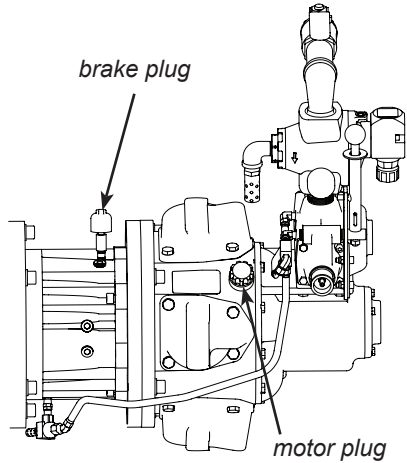

\* Disc brake shown

**⚠ CAUTION**

Make sure the breather plugs are clean and open to vent heat and pressure. Poor ventilation will cause overheating and result in damage to oil seals and other equipment. See Figure 3.

For shipment, the winch motor, disc brake and reducer are filled with lubricant and motor and disc brake breather plugs installed.

- 1.2.1 VERIFY THE BREATHER PLUG is installed on the motor and disc brake. Refer to the motor and brake manufacturer's information. The reducer is not equipped with a breather plug.
- 1.2.2 CHECK THE LUBRICANT LEVEL in the motor, brake and reducer to make sure no lubricant was lost during shipment. See section 3.2 - Lubricating the Winch.



## 1.3 Connecting the Air Supply

### Important!

- Use components rated for the power supply you will be using.
- Always disconnect the air supply when the winch is not in use. When removing the air hoses from the unit, plug the open ports.
- The F-L must be compatible with the required air supply.

### Important!

- If winch is DNV type approved, or CE marked, the regulator will be pre-set. If winch is CE marked, do not modify setting on regulator. See Figure 1 for assistance in determining if winch is DNV type approved or CE marked.

### ⚠WARNING

**Control devices must be momentary type. Install all control devices so the winch motor will stop when the operator releases the device.**

**Locate control devices so the operator will be able to view the load through the entire operation.**

**Locate control devices so the operator will be clear of the load, the wire rope, and the path of a broken wire rope that could snap back and cause injury.**

**Check that the direction indicators on control match load direction.**

**Remove port caps from exhaust ports for operation. Failure to do so may result in equipment damage and limit performance. See Figure 13.**

If it is the responsibility of the owner to provide equipment for controlling the winch, the following guidelines are supplied as a reference for the installer.

IF NOT PURCHASED WITH THE WINCH, INSTALL A FILTER-LUBRICATOR ON YOUR UNIT BEFORE WINCH OPERATION. (STANDARD WINCHES ARE EQUIPPED WITH A REGULATOR WHEN THEY LEAVE THE FACTORY) A FILTER-LUBRICATOR UNIT MUST BE USED WHILE OPERATING EQUIPMENT TO MAINTAIN WARRANTY. THERN WILL NOT COVER ANY DAMAGE TO EQUIPMENT CAUSED BY DIRTY, POOR, CONTAMINATED OR NON-LUBRICATED AIR SUPPLY. SEE FIGURE 4.

NOTE: CE marked and DNV type approved winches are shipped with pre-set regulators. If the winch is CE marked, do not adjust the regulator setting. To determine if the unit is CE marked or DNV type approved, check the serial tag. See Figure 1.

- 1.3.1 CONSULT APPLICABLE CODES AND REGULATION for specific instructions regarding power supply installation and backup.
- 1.3.2 CHECK THE COMPONENT MANUFACTURER'S INSTRUCTIONS for installing auxiliary equipment.
- 1.3.3 ENSURE an accessible shut off valve has been installed in the air supply line and make sure others are aware of its location.

**Figure 4 – Filter-Lubricator Unit (F-L)**

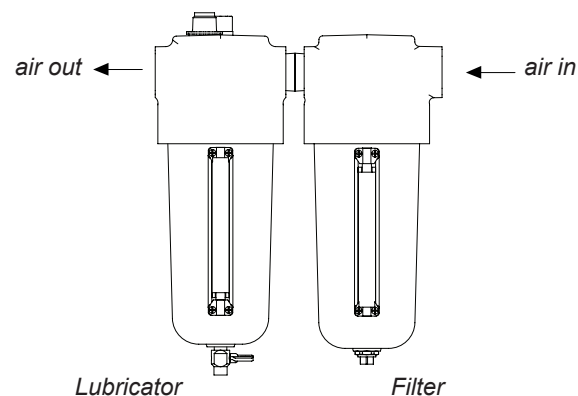

- 1.3.4 THE AIR SUPPLY must be clean and free from moisture.
- a ALL AIR SUPPLY LINES should be purged with clean, moisture free air or nitrogen before connecting to winch inlet.
  - b SUPPLY LINES should be as short and straight as installation conditions will permit. Long transmission lines and excessive use of fittings, elbows, tees, globe valves etc. cause a reduction in pressure due to restrictions and surface friction in the lines.
- 1.3.5 ALWAYS USE an air line lubricator with these motors.
- a THE LUBRICATOR must have an inlet and outlet at least as large as the inlet on the motor. Install the air line lubricator as close to the air inlet on the motor as possible.
  - b LUBRICATOR must be located no more than 10 ft. (3 m) from the motor.
  - c AIR LINE LUBRICATOR should be replenished daily and set to provide 6 to 10 drops per minute of SAE 10W oil. If ambient temperature of winch installation is below freezing, precautions must be taken to prevent the moisture in the air supply from freezing. Use an appropriate lubricant such as PolarLube or Killfrost. A fine mist will be exhausted from the exhaust ports when the air line lubricator is functioning properly.
- 1.3.6 IT IS RECOMMENDED that an air line strainer/filter be installed as close as practical to the motor air inlet port, but before the lubricator, to prevent dirt from entering the motor. The strainer/filter should provide at least 40 micron filtration and include a moisture trap. Clean the strainer/filter periodically to maintain its operating efficiency.
- 1.3.7 MOISTURE THAT REACHES THE AIR MOTOR through air supply lines is a primary factor in determining the length of time between service overhauls.
- a MOISTURE TRAPS can help to eliminate moisture.
  - b AIR RECEIVERS collect moisture before it reaches the motor.
  - c INSTALLING AN AFTERCOOLER at the compressor that cools the air to condense and collect moisture prior to distribution through the supply lines is also helpful.
- 1.3.8 THE AIR MOTOR SHOULD BE INSTALLED as near as possible to the compressor or air receiver. Recommended pressures and volumes are measured at the point of entry to the air motor.
- 1.3.9 CHECK THE AIR PRESSURE at the motor inlet and make sure it agrees with the pressure rating marked on the winch nameplate.
- 1.3.10 TEST AIR CONNECTIONS by slowly opening the air line to ensure air connections are sound prior to moving load. Then gradually operate the winch.
- a ROTATION OF THE DRUM must agree with the labels on the control device as indicated on the labels for the control device.
  - b CHECK THE AUTOMATIC LOAD BRAKE(S), make sure it releases when the motor is ON, and engages when the motor is OFF.

CONTACT THE FACTORY OR A QUALIFIED PROFESSIONAL FOR HELP.

## 1.4 Installing the Mufflers

**Figure 5a – Single Muffler**

*muffler installed in  
valve exhaust ports*

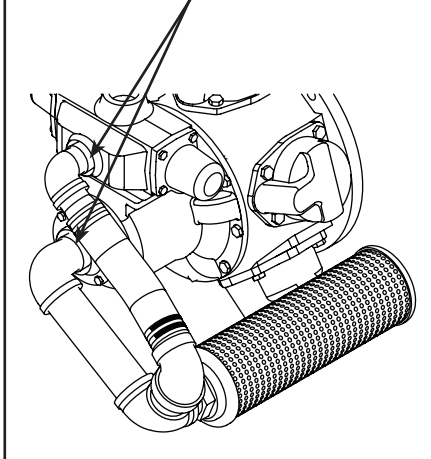

**⚠ CAUTION**

It is recommended that persons use hearing protection when working with or near the winch while in operation.

If not purchased with the winch, install mufflers in both exhaust ports to reduce noise. See Figure 5.

**Sound Level:**

**Without Muffler:** Contact factory.

**With Muffler (TA-MF3):** Contact factory.

**With Muffler (TA-SMF3):** Contact factory.

**Figure 5b – Double Muffler**

*muffler installed in  
valve exhaust port*

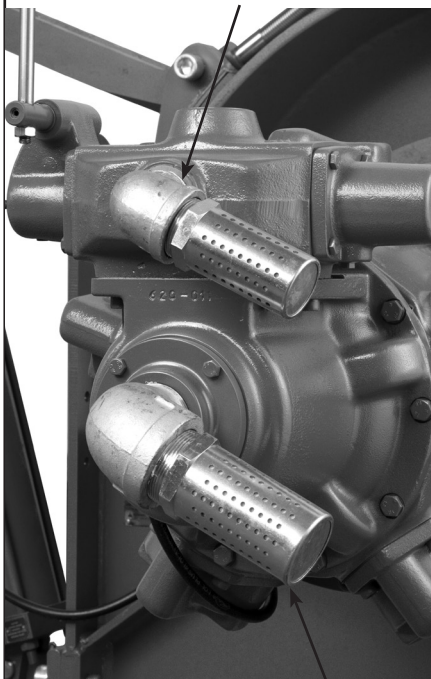

*muffler installed in  
motor exhaust port*

## 1.5 Adjusting the Drum Guard (if equipped)

### **⚠WARNING**

Do not adjust or remove drum guard panels while winch is in use.

If drum guard is installed on winch, shift/re-locate the panels of the drum guard to leave sufficient clearance between the drum guard and wire rope. **Do not allow wire rope to come into contact with drum guard panels during winch operation.** Be sure to take into account the range of layers intended to be used for the duration of the installation of the winch and the intended fleet angles of the rope. Panels can be removed by loosening the fasteners at the ends of the panels. Once loose, remove panel and others as needed. Store un-needed panels or re-install them elsewhere on the drum guard frame. See Figure 6.

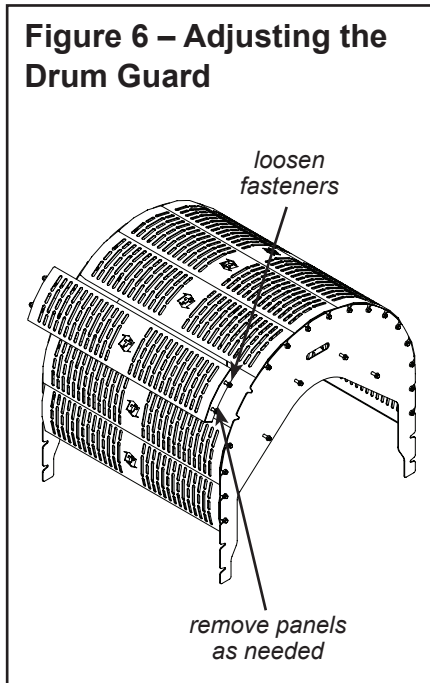

## 1.6 Positioning the Pressure Roller (if equipped)

1.6.1 DETERMINE THE DIRECTION the rope will be wound onto the drum, and at what elevation angle it will need to exit from the drum.

1.6.2 FOLLOW THE GUIDELINES in Figure 7 to determine if the pressure roller will need to be moved to the other side of the winch drum. If pressure roller needs to be moved, follow the procedure below:

**NOTE:** On TA10C models equipped with a drum lock, the pressure roller can not be moved to the other cross bar.

- a PULL OUT on the pressure roller arm to expose the pin hole(s) in the spring arm(s).
- b INSERT a spring pin, cotter pin, or equivalent into the hole to lock the springs open.
- c UNFASTEN the spring mount from the winch frame.
- d UNFASTEN the cross bar containing the pressure roller arm and remove the pressure roller arm.
- e REFASTEN the cross bar onto the frame. Apply medium (blue) thread locker to fastener threads and torque to 49 ft-lbs (TA2.5C). For TA5C and TA10C models, apply medium (blue) thread locker and torque to 121 ft-lbs.
- f REMOVE the opposite cross bar and install the pressure roller arm onto it. Refasten the cross bar with pressure roller arm onto the winch. Apply medium (blue) thread locker to fastener threads and torque to 49 ft-lbs (TA2.5C). For TA5C and TA10C models, apply medium (blue) thread locker and torque to 121 ft-lbs.
- g REFASTEN the spring mount(s) to the appropriate hole(s) in the frame.
- h PULL OUT on the pressure roller arm to relieve pressure on the locking pins and remove the pins. Slowly let the pressure roller spring back into operational position.

Figure 7 – Wire Rope Exit Angle Guidelines

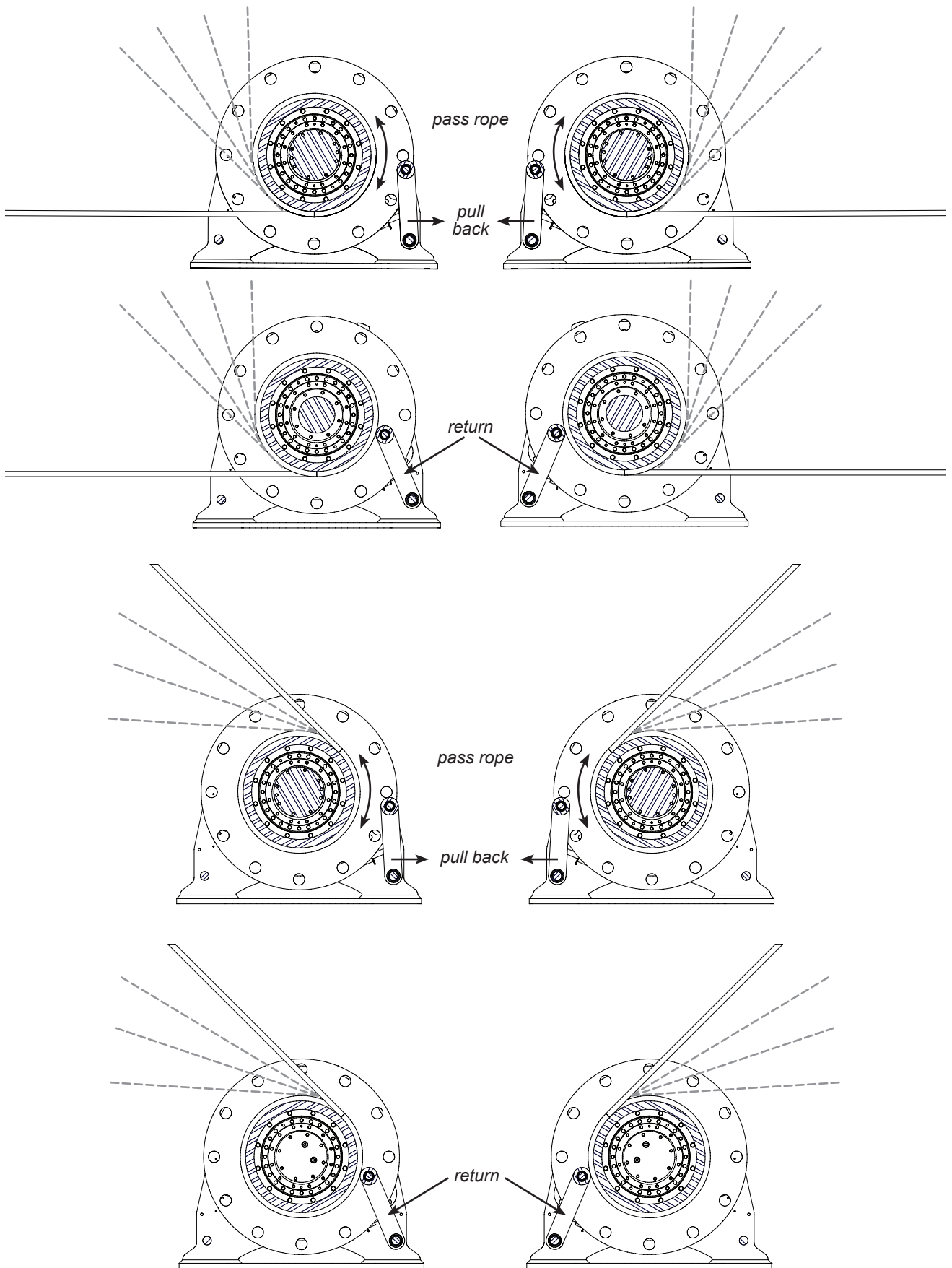

## 1.7 Installing the Wire Rope

### Important!

- Winch is made for the size of wire rope as indicated on the serial tag of the winch (See Figure 1). Verify that the wire rope and other rigging equipment is rated for the largest load you will be moving.
- Do not drag the wire rope through dirt or debris that could cause damage, or poor operation.
- Always wear protective clothing when handling wire rope.

**Figure 8 – Support Bars**

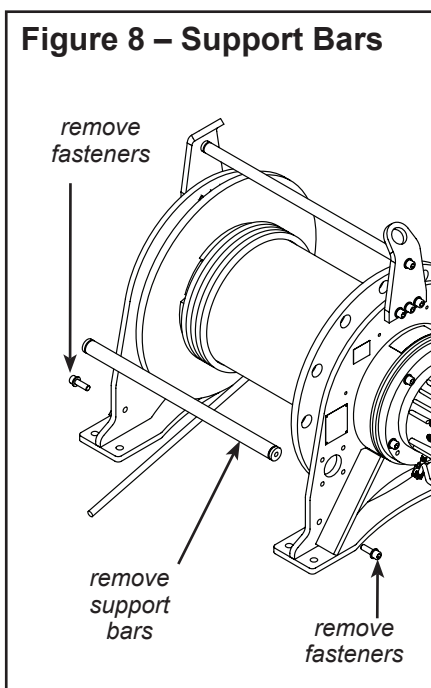

### ⚠WARNING

**Install the wire rope securely to the winch drum. A poorly secured wire rope could come loose from its anchor and allow the load to escape.**

- 1.7.1 DETERMINE WHICH DIRECTION the drum must rotate to wind and unwind wire rope.
- 1.7.2 PURCHASE THE PROPER WIRE ROPE for your application. Keep the following in mind when selecting a wire rope. Contact a reputable wire rope supplier for help. Winch is designed for a specific size of wire rope. See Figure 1B for assistance in locating your serial tag which will indicate the wire rope size for your winch.
  - a BREAKING STRENGTH of new wire rope should be at least 3 times greater than the largest load placed on the winch. If loads are lifted or pulled on an incline, the breaking strength must be at least 5 times greater than the largest load. These are minimum values and will vary with the type of load and how you are moving it.
  - b WIRE ROPE LAY must agree with the winding direction of the drum to help insure proper winding.
  - c WE RECOMMEND 6 x 37 IWRC improved plow steel (IPS) or extra improved plow steel (EIPS) wire rope.
- 1.7.3 ANCHOR THE WIRE ROPE to the drum using the wedge socket in the drum. See Figure 9.
  - a PULL BACK on the pressure roller bar to pass the rope between the drum and the rollers (if applicable). See section 1.6 - Positioning the Pressure Roller.
  - b PASS THE WIRE ROPE through the drum wedge socket, then around the wedge as shown in Figures 9 and 10.
  - b PULL ROPE TIGHT so wedge is set securely in the drum wedge socket.
- 1.7.4 REMOVE no more than one of the two lower support bars after winch has been installed, if needed to achieve greater wire rope payout angle range. See Figure 8. Consult Thern if further payout angle ranges are needed.
- 1.7.5 WIND FIVE FULL WRAPS of wire rope onto the drum by operating the winch while holding the wire rope taught. These wraps serve as anchor wraps and must remain on the drum at all times.

**Figure 9a – TA2.5C and TA5C Wire Rope Installation Procedure**

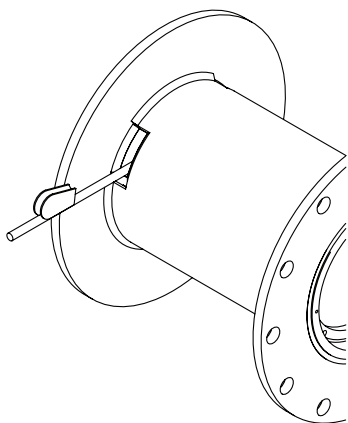

**Step 1**  
Pass wire rope through wedge socket.

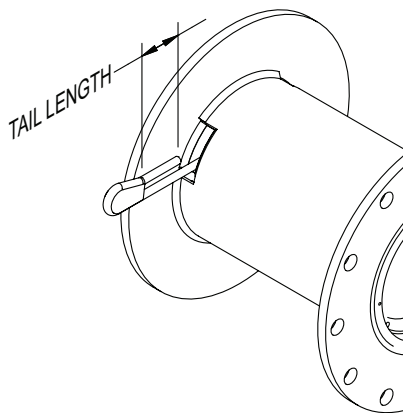

**Step 2**  
Pass rope around wedge - tail length to be a minimum of 6 rope diameters but not less than 6 inches (152.5 mm).

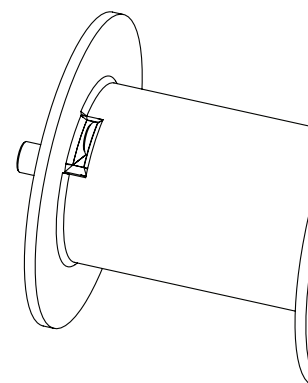

**Step 3**  
Set wedge in socket.

**Figure 9b – Correct / Incorrect Wire Rope Installation**

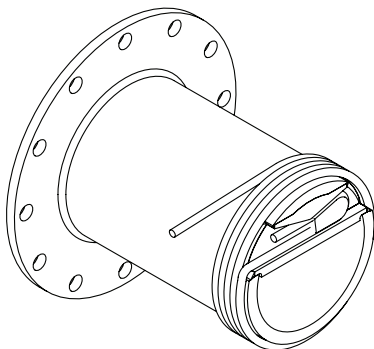

**CORRECT**  
Clockwise payout.

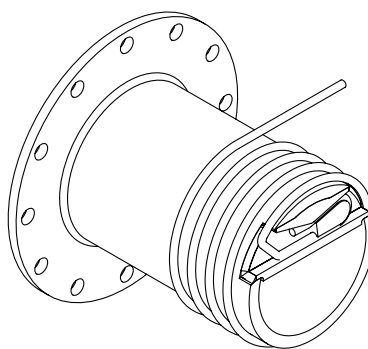

**INCORRECT**  
Counter-clockwise payout with clockwise wedge position AND wire rope wrapped loosely.

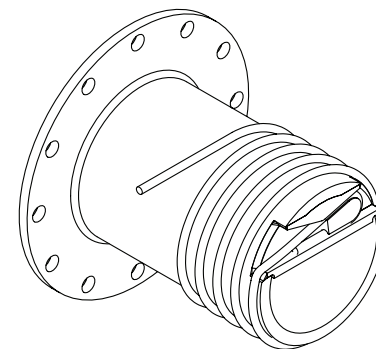

**INCORRECT**  
Wire rope exiting wrong side of wedge AND wire rope wrapped loosely.

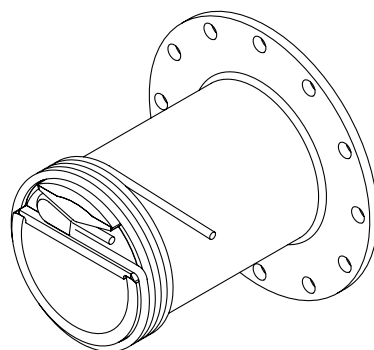

**CORRECT**  
Counter-clockwise payout.

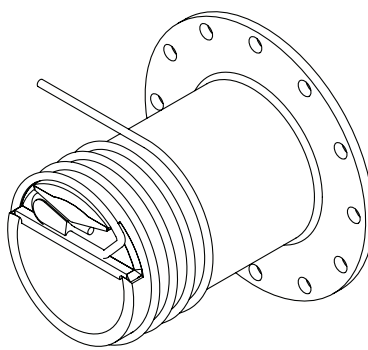

**INCORRECT**  
Clockwise payout with counter-clockwise wedge position AND wire rope wrapped loosely.

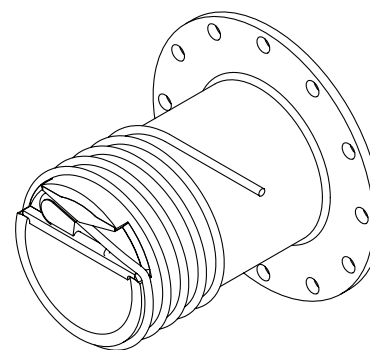

**INCORRECT**  
Wire rope exiting wrong side of wedge AND wire rope wrapped loosely.

**NOTE:** Drum rotation direction is from the motor end of the winch.

**Figure 10 – TA10C Wire Rope Installation Procedure**

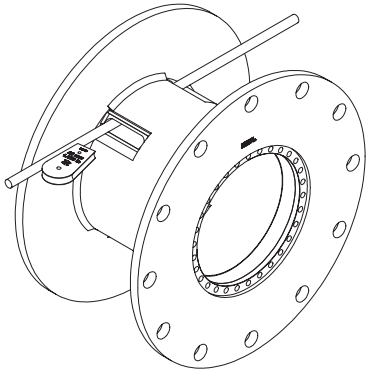

**Step 1**  
Pass wire rope through wedge socket.

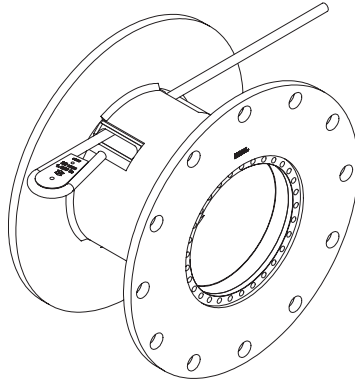

**Step 2**  
Pass rope around wedge - tail length to be 1 to 3 inches (25.4 to 76.2 mm).

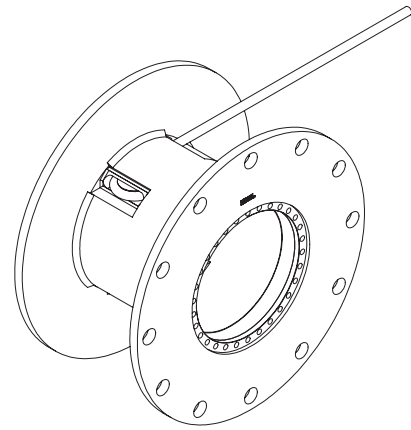

**Step 3**  
Set wedge in socket.

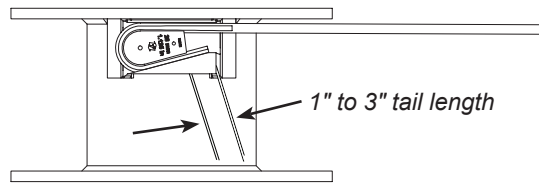

**Wedge Correctly Installed**

**Wire Rope in Opposite Direction**

For wrapping the rope the opposite direction, use the opposite cable anchor socket and repeat the same steps.

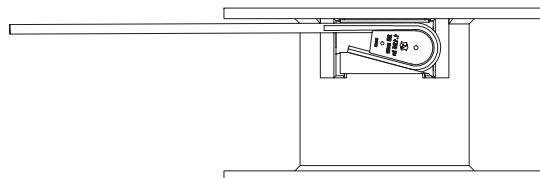
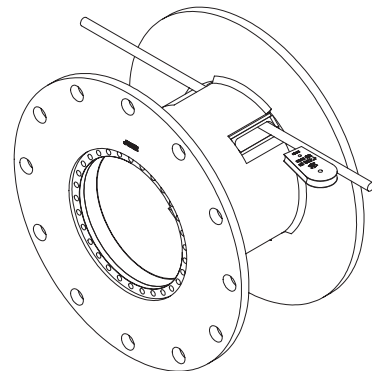
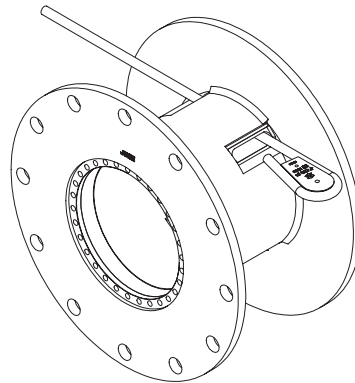
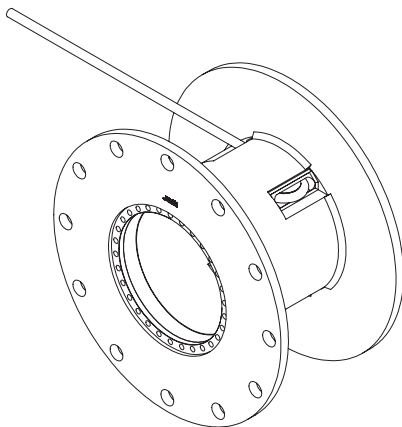



## 1.8 Setting Travel Limits (if equipped)

### **CAUTION**

Limit set points are dependent on speed of operation, use caution with setting limits. Typically, limits should be set for the highest speed to be encountered. A trained operator should be closely monitoring winch operation while using these switches to ensure that a mis-adjusted switch does not allow load to move beyond the specified range. Travel limits are not intended as the primary means of stopping winch operation or for the positioning of the load, they are to prevent over travelling.

1.8.1 SET LIMITS doing the following:

- a REMOVE the limit switch cover.
- b LOOSEN the large locking screw in the center of the column. Figure 11. Individual limits can now be set.
- c DETERMINE WHICH DIRECTION the limit switch cam rotates when the drum rotates clockwise.
- d TURN THE SCREW that rotates the top cam until movement of the valve plunger is seen on the clockwise drum rotation limit valve, giving a starting point for adjusting the limit. Operate the winch and make adjustments until the operation is stopped by the switch at the desired location.
- e REPEAT THE PROCESS for the screw that rotates the third cam from the top, adjusting the counterclockwise drum rotation limit valve cam. See Figure 11.
- f AFTER SETTING BOTH LIMITS tighten the locking screw and re-check the limits.
- g REPLACE the cover.

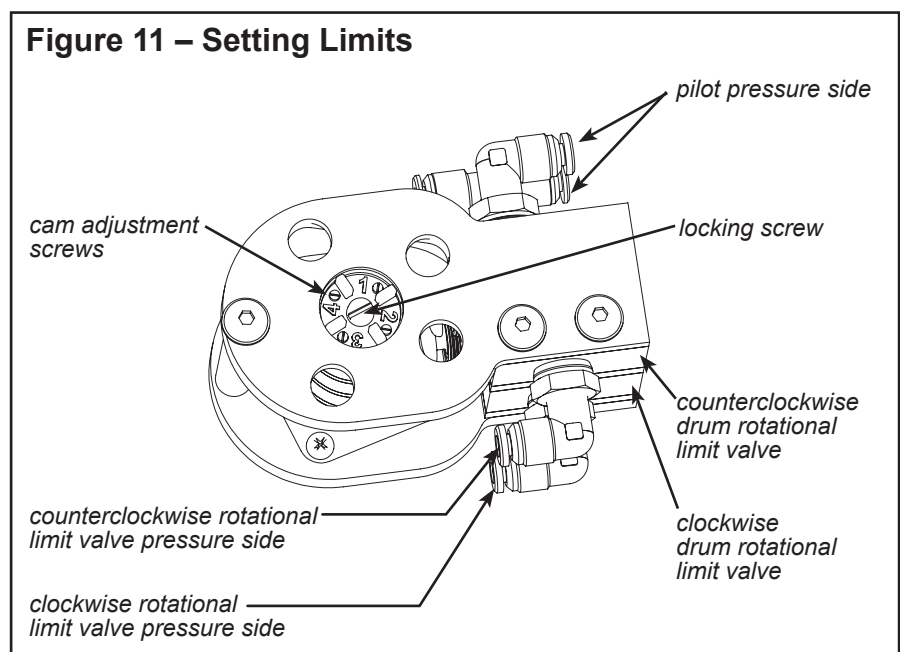

## 2.1 General Theory of Operation

### Important!

- Limit nonuniform winding by keeping tension on the wire rope and by maintaining the proper fleet angle.
- To help ensure rated performance, make sure the air pressure at the motor is equal to the motor's pressure rating.
- It is your responsibility to detect and account for different factors affecting the condition and performance of the equipment.
- When determining whether the load will exceed the load rating, consider the total force required to move the load.

- 2.1.1 THE FORCE REQUIRED to move the load must not exceed the load rating of the winch. Consider the total force required to move the load, not the weight of the load.
- 2.1.2 THIS EQUIPMENT CAN develop forces that will exceed the load rating. It is the responsibility of the equipment user to limit the size of the load. Inspect the equipment regularly for damage according to the instructions contained in this manual and in the component manufacturer's information.
- 2.1.3 USE A LOAD BRAKE on all winches used to lift loads or drag loads on an incline. When engaged, the disc brake locks the drive train to the winch frame, thereby stopping drum rotation when the control is released or placed in the neutral position.
- 2.1.4 PERFORMANCE RATINGS of the equipment are affected by the amount of wire rope wound on the drum, the way in which it is wound, air power supply, and the way the winch is used.
- a DRUM CAPACITY depends on how tightly and evenly the wire rope is wound on the drum. Actual drum capacities are usually 25-30% less than values shown in performance tables, due to loose winding and overlapping.
  - b LINE SPEED increases with each additional layer of wire rope wound onto the drum. Line speed will also vary with load weight and air power supply.
  - c LOAD RATING represents the maximum force that can be placed on new equipment. Load ratings are assigned values for specific amounts of load travel or wire rope accumulation.
- 2.1.5 DUTY RATINGS refer to the type of use the equipment is subject to. Consider the following when determining duty rating.
- a ENVIRONMENT: harsh environments include hot, cold, dirty, wet, corrosive, or explosive surroundings. Protect the equipment from harsh environments when possible.
  - b MAINTENANCE: poor maintenance, meaning poor cleaning, lubrication, or inspection, leads to poor operation and possible damage of the equipment. Minimize poor maintenance by carefully following the instructions contained in this manual.
  - c LOADING: severe loading includes shock loading and moving loads that exceed the load rating of the equipment. Avoid shock loads, and do not exceed the load rating of the equipment.
  - d FREQUENCY OF OPERATION: frequent start and stop functions increase wear and shorten the life span of the gear train and load brake components. Lengthy operations cause lubrication to become hot, which also decreases the life span of the gear train and brake. Increase maintenance of the equipment if used in frequent operations.

CONTACT FACTORY FOR MORE INFORMATION.

---

## 2.2 Breaking-In The Winch

**⚠WARNING**

**Remove exhaust port caps for operation (if applicable). Failure to do so may result in equipment damage and limit performance. See Figure 13.**

- 2.2.1 BEFORE THE WINCH IS PLACED INTO SERVICE or for winches that have been in storage for a period of more than one month, the following start-up procedure is required.
  - a INSPECT THE WINCH and other equipment according the Instructions for Periodic Inspection.
  - b WHEN FIRST OPERATING THE WINCH it is recommended that the motor be driven slowly in both directions for a few minutes.
  - c ENSURE BRAKE HOLDS prior to making complete lift by lifting load a short distance and releasing control.
- 2.2.2 PRIOR TO INITIAL USE, all new, altered or repaired winches shall be tested to ensure proper operation. See section 3.3.4 h.
  - a CHECK THAT THE OIL LEVEL in motor, reduction gear assembly and disc brake are correct.
- 2.2.3 INSPECT THE WINCH following the break-in according to the Instructions for Periodic Inspection. See section 3.3 - Inspecting the Equipment.

## 2.3 Preparing for Operation

Figure 12 – Signals



*hoist*



*lower*



*stop*



*dog everything*

### **▲WARNING**

Read and comply with the guidelines set forth in this Owner's Manual. Keep this manual and all labels attached to the winch, readable and with the equipment at all times. Contact Thern, Inc. for replacements.

Do not lift people or things over people. Do not walk or work under a load or in the line of force of any load.

Do not exceed the load rating of the winch or any other component in the system. To do so could result in failure of the equipment.

The winch must be equipped with a load brake if it is used to lift loads or drag loads on an incline.

Do not use more than one winch to move a load unless each winch was designed for a multiple winch system.

Do not use damaged or malfunctioning equipment. To do so could result in failure of the equipment.

Do not modify the equipment in any way. To do so could cause equipment failure.

Do not operate the winch with guards removed or improperly installed.

Check lubrication levels before use.

2.3.1 CONSIDER THE OPERATION. Do not begin until you are sure you can perform the entire operation without hazard.

2.3.2 A PRE-OPERATION MEETING attended by the winch operator, ground crew, signalperson, persons to be lifted and the person in charge of the task to be performed shall be held to plan and review the procedure to be followed, including:

- Signals. See Figure 12 for possible signals to be used.
- Appropriate number of signal persons and ground crew.
- Designate responsibility.

a THIS MEETING SHALL BE HELD prior to the beginning of operations at each new work location and thereafter for any new employees assigned to the operation.

b DURING THIS MEETING it is recommended that a comprehensive plan to cover emergency procedures be worked out prior to exercising the winch capabilities.

2.3.3 INSPECT ALL COMPONENTS of the system.

a INSPECT THE WINCH and other equipment according to the Instructions for Frequent Inspection.

- b OPERATORS shall be physically competent and have no health condition which might affect their ability to act, and they must have good hearing. Operators who are fatigued or have exceeded their normal shift period shall check all related regulations regarding approved work periods prior to operation. The operator must thoroughly understand proper methods of rigging and attaching loads and should have a good attitude regarding safety.
  - c THE LOAD must be clear of other objects and free to move. Make sure the load will not tip, spin, roll away, or in any way move uncontrollably.
- 2.3.4 KNOW YOUR LOAD and make sure you do not exceed the load rating of the winch or any other equipment in the system.

---

## 2.4 Air Valve Adjustment

### **⚠WARNING**

**Make sure to check the adjustment of the payout air valve flow restrictor screw if winch operating speeds differ from performance specifications during lowering or pay out of wire rope.**

**Do not adjust the flow restrictor while suspending or hoisting a load.**

- 2.4.1 ADJUSTMENT FOR LIFTING APPLICATIONS - SEE FIGURE 13.

**NOTE: This adjustment setting is only a recommendation for initial startup in order to prevent over speeding while lowering. The actual adjustment required is dependent on the load and the specific unit purchased.**

- a LOOSEN NUT AND ADJUST SCREW located in the valve end cap.
  - b ADJUST UNTIL DRUM SPEED for full load pay-out is equal to or less than the drum speed for no-load haul-in.
  - c TIGHTEN THE NUT when drum speed is adjusted.
- 2.4.2 ADJUSTMENT FOR PULLING APPLICATIONS - SEE FIGURE 13.
- a LOOSEN NUT AND ADJUST SCREW located in the valve cap end.
  - b ADJUST UNTIL DRUM SPEED for no-load payout equals the drum speed for no-load haul in.
  - c TIGHTEN NUT when drum speed is adjusted.

Figure 13 – Motor and Valve

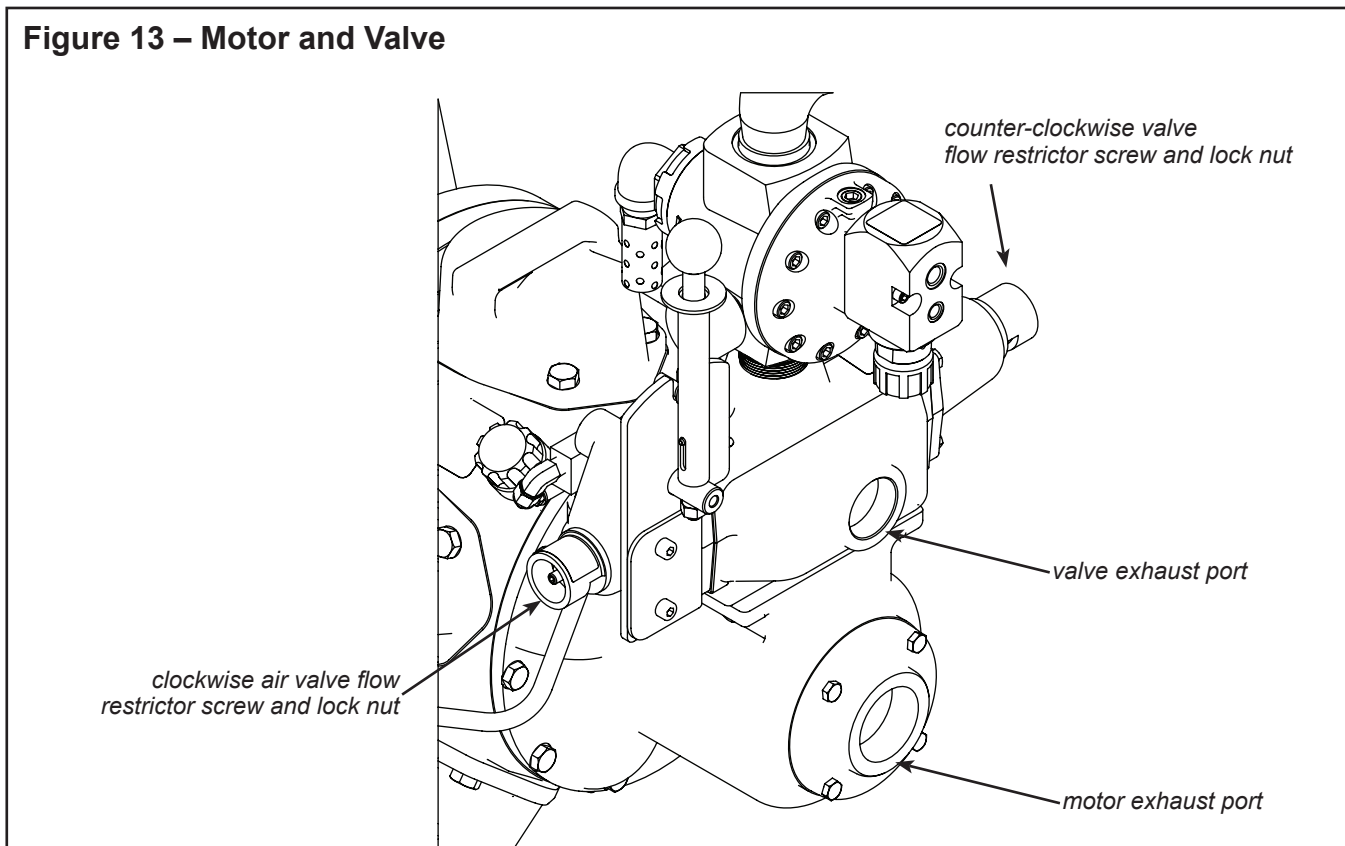

## 2.5 Attaching the Load

### **⚠WARNING**

Do not wrap the wire rope around the load. This damages the wire rope and could cause the load to escape. Use a sling or other approved lifting device.

Fig. 14 – Attaching Load

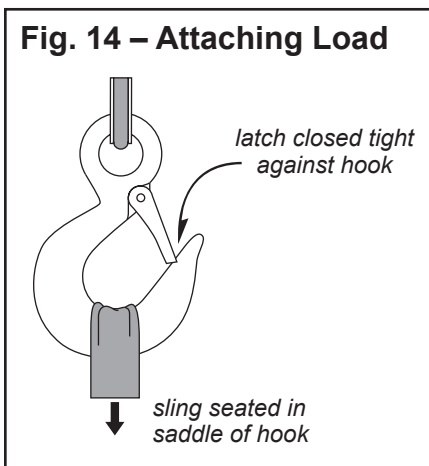

- 2.5.1 CLEAR OBJECTS from the path of the load so you can move it freely and observe it at all times during the operation.
- 2.5.2 ATTACH THE LOAD using a nylon sling, or other approved lifting device. Follow the recommendations of the sling manufacturer.
  - a SEAT THE SLING in the saddle of the hook with the hook latch completely closed. See Figure 14. Always make sure the load is properly seated in the saddle of the hook. Do not tipload the hook as this may allow the load to slip out of engagement and leads to spreading and eventual failure of the hook.
  - b CENTER THE LOAD on the hook so it will remain balanced and not tip or rotate to one side.

## 2.6 Moving the Load

### Important!

- Obey a stop signal from anyone.
- Maintain tension on the wire rope to keep it tightly and evenly wound on the drum.
- If the winch and load are not visible during the entire operation, get help from another person.
- Appoint a supervisor if more than one person is involved in the operation. This will reduce confusion and increase safety.
- When lifting a load, use a tag line to keep the load from swinging or twisting, while keeping yourself away from the load.
- Lifting and lowering speeds shall be operator-controlled and be as slow as practical.
- The winch operator shall remain at the controls at all times.

Figure 15a – Control Valve

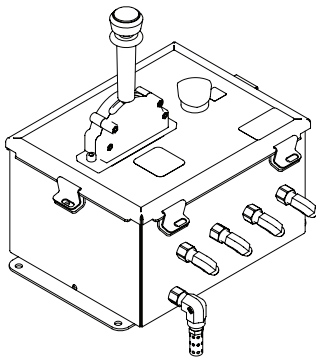
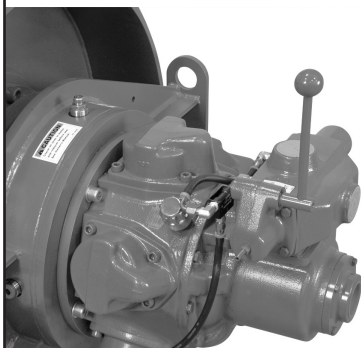

Figure 15b – Control Valve



### ⚠WARNING

Keep at least 5 wraps of wire rope wound on the drum at all times, to serve as anchor wraps. With less than 5 wraps on the drum the wire rope could come loose, causing the load to escape.

Keep all unnecessary personnel away from the winch. Keep out of the path of the load, and out of the path of a broken wire rope that might snap back and cause injury.

Keep hands away from the drum, gears, wire rope, and other moving parts of the equipment.

Winches must use controls that spring return to neutral and stop all motion when released. Various controls are available with the winches and are dependent on air supply, location to winch and degree of control required.

Operators must maintain visual or audio contact with personnel and the load at all times. Operators must remain at the controls at all times.

Monitor surrounding conditions to prevent the load from contacting hazardous obstructions.

Use spotters or signal person to assist with positioning the load in confined or limited visibility areas.

Do not divert your attention from the operation. Stay alert to the possibility of accidents, and try to prevent them from happening.

Do not jerk or swing the load. Avoid shock loads by starting and stopping the load smoothly. Shock loads overload the equipment and may cause damage.

Do not leave a suspended load unattended unless specific precautions have been taken to secure the load and keep people away from the winch and out from under the load.

2.6.1 MOVE THE LOAD slowly and smoothly, only a small distance at first. Make sure the load is balanced and securely attached before continuing.

#### Before operating, the following conditions shall exist:

- WIRE ROPE shall be free of kinks.
- MULTIPLE PART LINES shall not be twisted around each other.
- THE PRIMARY POINT of wire rope attachment shall be centered over the load so that the load will not tilt and remain level.
- IF THERE IS SLACK wire rope condition, the hoisting mechanisms shall be inspected to ensure all wire ropes are properly seated on drums and in sheaves, before resuming winch operation.

2.6.2 USE THE CONTROL DEVICE to operate the winch. The control device must be momentary type, so the winch will stop when the operator releases the control. See Figure 15.

- 2.6.3 THE AUTOMATIC DISC BRAKE is a spring applied, air released brake. The brake automatically disengages when the motor is operated. When the control valve is placed in the neutral position, the brake automatically engages preventing drum rotation.
- 2.6.4 OBSERVE THE WIRE ROPE as it winds onto the drum. If it becomes loose, uneven, or overlapped, stop the operation and rewind the wire rope before continuing. Continued operation with overlapped or uneven wire rope can damage the wire rope and shorten its life.
- 2.6.5 OBSERVE THE REDUCER, MOTOR AND BRAKE during operation for signs of overheating. Frequent overheating may be a sign of damage, or may indicate the need for a larger power winch.
  - a WATCH FOR SMOKE, the smell of burnt lubricant, and other signs of overheating. Use a thermocouple or other device to monitor reducer temperature.
  - b STOP THE OPERATION if the reducer, motor or brake overheats, and allow the winch to cool. Continued operation may cause damage.
- 2.6.6 IN CASE OF AIR SUPPLY FAILURE, see section 2.8 - Emergency Operation.
- 2.6.7 USE GLOVES designed to reduce the impact of vibration if controlling winch by manual lever on the control valve.

**NOTE: VERTICAL VIBRATION**

Vibration Level: Contact factory.



## 2.7 Using the Drum Lock

### ⚠WARNING

Do not try to operate the winch with the drum lock engaged.

Do not try to engage the drum lock with the winch drum in motion.

**Figure 16a – Drum Lock Engaged**

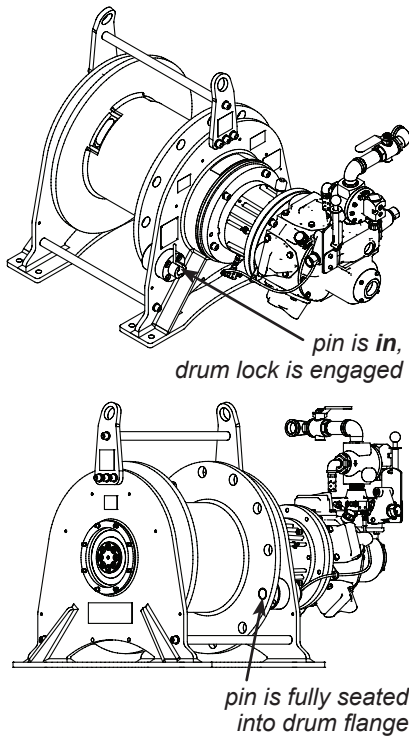

#### 2.7.1 TO ENGAGE THE DRUM LOCK:

- a ALIGN the drum lock hole with the pin by operating the winch.
- b PULL OUT on the drum lock handle.
- c ROTATE the handle until it is aligned with a deep groove in the handle housing.
- d LET the locking pin spring pull the pin into the locked position.
- e CHECK to verify that the locking pin is fully seated into the drum flange. See Figure 16a.

#### 2.7.2 TO DISENGAGE THE DRUM LOCK:

- a PULL OUT on the drum lock handle. If the handle does not come out easily, relieve any pressure that might be applied to the locking pin by carefully operating the winch to move the drum. **Do not intentionally slam the drum back and forth with the drum lock engaged.** As a last resort, the disk brake can be released to turn the drum manually until the drum locking pin is free. See sections 2.8.1 or 2.8.3 for releasing the brake.
- b ROTATE the handle until it is aligned with the raised shoulder in the handle housing.
- c RELEASE the handle and let it rest on the housing shoulder.
- d CHECK to verify that the locking pin is fully disengaged from the drum flange. See Figure 16b.

**Figure 16b – Drum Lock Disengaged**

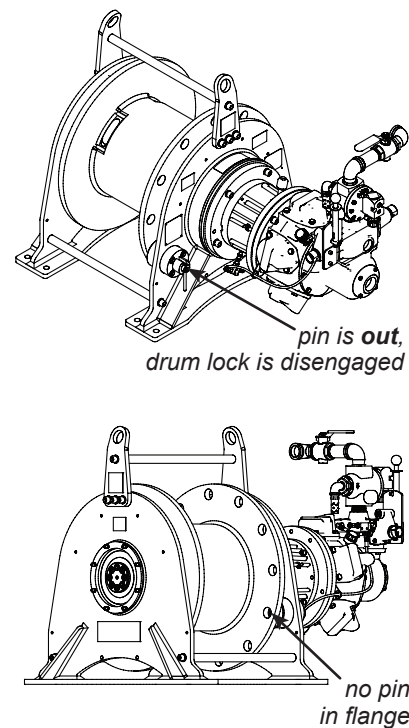

## 2.8 Emergency Operation

**▲WARNING**

Emergency lowering operations must be performed by a minimum of two personnel trained in the operation of the winch.

Communication must be established between personnel and the winch operator. The operator should be able to visually monitor the load through its full range of travel.

### OPERATING WINCH IN THE EVENT OF POWER FAILURE

Your winch may be equipped with an emergency brake release (see Figure 17a) or a power diverter (see Figure 17b).

2.8.1 EMERGENCY OPERATION PROCEDURE for winch with emergency brake release.

a The winch is equipped with an automatic disc brake which is spring set and air released. In the event of a power failure, the brake will set until air is supplied to release it. This emergency brake release will supply air to the brake, allowing it to release. If air supply to winch is lost when a load is suspended, this option provides a means to safely lower the load to the ground, provided that the load meets or exceeds the minimum stripping weight (see Table 1). If the load weighs less than this, you may need to attach a line to the load to assist with lowering the load.

b When ready to lower the load, gradually press the thumb lever to supply air to the brake. Take care to make the minimum number of starts and stops as you can to lower the load. See Figure 17a.

2.8.2 EMERGENCY OPERATION PROCEDURE for winch with a power diverter.

a The winch is equipped with an automatic disc brake which is spring set and air released. In the event of a power failure, the brake will set until air is supplied to release it. The power diverter allows you to provide a secondary air source to the winch without removing the original supply line of air.

b If needing to use the secondary air supply, remove plug and install secondary air line. When ready to lower the load, use the ball valve to connect the air circuit from the secondary supply to the winch. See Figure 17b.

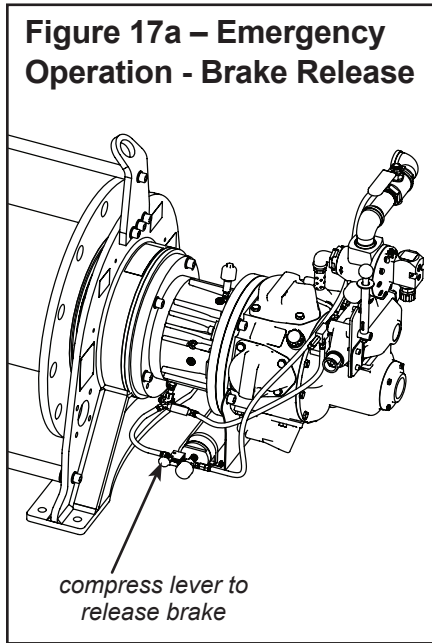

**Table 1 – Minimum Stripping Weights**

SERIES	WEIGHT (lbs)
TA2.5C	300
TA5C	1000
TA10C	2500

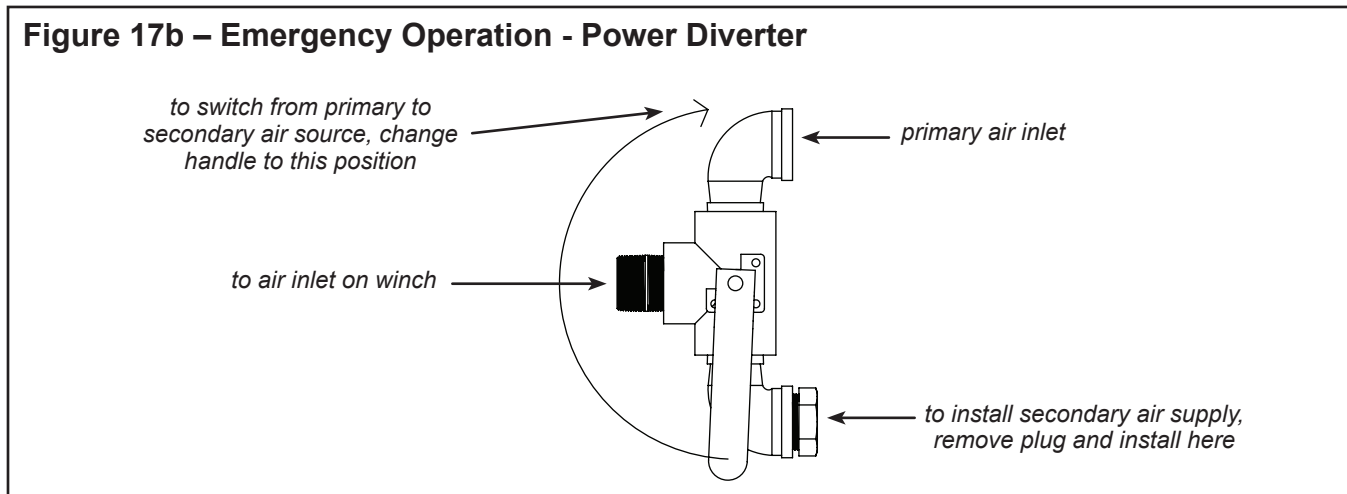

2.8.3 ALTERNATIVE SECONDARY AIR SUPPLY CONNECTION

a STEPS FOR EMERGENCY LOWERING:

- The winch is equipped with an automatic disc brake which is spring set and air released. In the event of a power failure, the brake will set until air is supplied to release it.
- In case of air supply failure, shut off air supply to winch
- Install a regulator and proportional control valve capable of releasing the air pressure to actuate the brake.
- Regulate the air down to the pressure recommended on the serial tag. See Figure 1.
  - Supply a secondary source of air to the inlet port of the regulator. **Do not pressurize until ready to lower the load.**
- With air pressure supplied to the brake, control line speed with proportional control valve, exercising caution and lowering the load at a slow and controllable speed. The minimum pressure needed is 45 psi (3.1 bar).
- Remove the load from the load line.

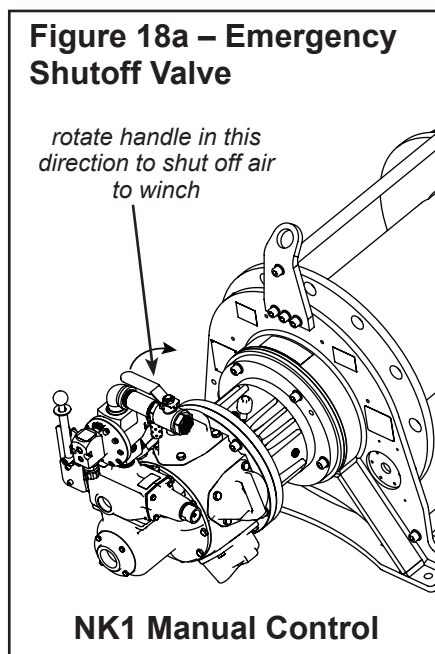

**SHUTOFF VALVE/EMERGENCY STOP OPERATION**

Your winch is supplied with a shutoff valve (see Figure 18a), or an emergency stop button (see Figure 18b).

2.8.4 If winch is supplied with a shutoff valve, when need arises to stop or remove the air supply to the winch, turn the handle of the valve to the closed position to stop air flow to the winch and relieve air from the winch. Once the situation has been resolved, return the handle of the shutoff valve to the open position slowly, to gradually return air supply to the winch. See Figure 18a.

2.8.5 If winch is supplied with an emergency stop button, when need arises to stop or remove the air supply from the winch, engage the emergency stop button by pressing it down. Once the situation has been resolved, release emergency stop button by rotating it clockwise. See Figure 18b.

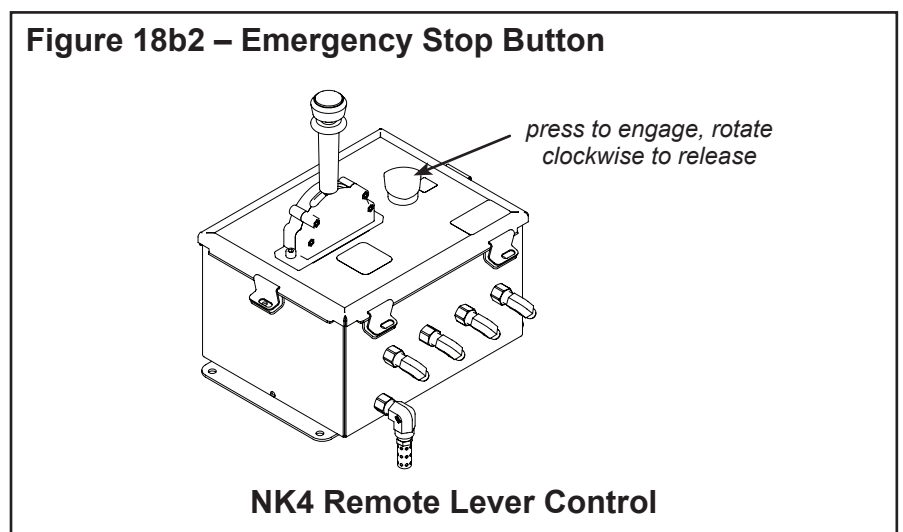
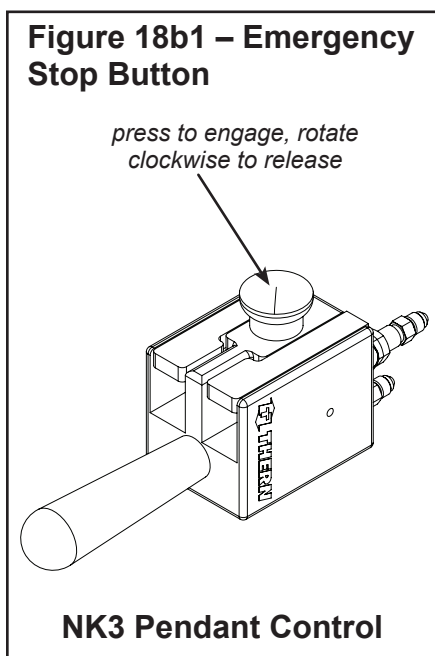

### 3.1 Cleaning the Winch

#### Important!

Increase the frequency of maintenance procedures if the winch is:

- Operated for long periods.
- Used to pull heavy loads.
- Operated in wet, dirty, hot or cold surroundings.

Clean the winch to remove dirt and help prevent rust and corrosion.

- 3.1.1 CLEAN THE WINCH every six months or whenever it is dirty. Wipe down all equipment to remove dirt and grease on and around winch, noting that the muffler(s) if installed may have lubricant on or below them.
- a WIPE ALL EQUIPMENT to remove dirt and grease.
  - b LEAVE A LIGHT FILM of oil on all surfaces to protect against rust and corrosion.
  - c WIPE OFF excessive amounts of oil to avoid accumulation of dirt.
  - d REMOVE oil accumulation from around the winch caused by lubrication in the exhaust.
- 3.1.2 REMOVE ALL UNNECESSARY OBJECTS from the area around the winch.

### 3.2 Lubricating the Winch

#### ⚠ CAUTION

**Make sure the breather plugs are clean and open to vent heat and pressure. Poor ventilation will cause overheating and result in damage to oil seals and other equipment.**

**Fill the reducer, disc brake and motor to the proper level without overfilling. Too much or too little lubricant will cause overheating and result in damage to equipment.**

For shipment, the winch motor, disc brake and reducer are filled with lubricant and motor and disc brake breathers installed.

- 3.2.1 LUBRICATE THE REDUCER, DISC BRAKE AND MOTOR according to the following instructions.
- a FILL THE REDUCER, DISC BRAKE AND MOTOR with oil before operating the winch. Fill the reducer, disc brake and motor until oil reaches the level check plug or recommended level in the sight tube. **Do not mix different lubricants.** See Tables 2 and 3.
  - b CHECK OIL LEVEL before every operation and every 10 hours during operation. Remove the level plug and make sure oil is even with the plug hole or is at the recommended level in the sight tube. See Figure 19.
  - c CHANGE REDUCER, DISC BRAKE AND MOTOR LUBRICANT at least every 2 years, or whenever it is dirty or contaminated. See Figures 20 and 21.
  - d THE REDUCER is not equipped with a breather plug.

#### Important!

- Do not leave plug holes in the reducer or motor open. Open plug holes will allow dirt and moisture to contaminate the lubrication.
- Make sure lubricant has a temperature rating appropriate for the ambient temperatures of the operation.
- Lubricate the winch properly to help protect it from wear and rust. Read the following instructions carefully.

- 3.2.2 LUBRICATE THE WIRE ROPE by following the wire rope manufacturer's recommendations.
- 3.2.3 LUBRICATE the drum shaft bearing (TA10C only). TA2.5C and TA5C are supplied with sealed bearings that are maintenance-free.
- LUBRICATE the bearing at least every 10 hours of operation. See Figure 19.
  - REMOVE all plugs in the bearing cover plate and install a grease zerk in the bottom hole.
  - PUMP NLGI #2 EP grease through the grease zerk until it reaches the level plug hole in the cover plate.
  - RE-INSTALL all plugs in their original locations.
- 3.2.4 IF WINCH IS DISASSEMBLED, clean all parts thoroughly and coat bearings and seals with clean grease. Use sufficient grease to provide a good protective coat.

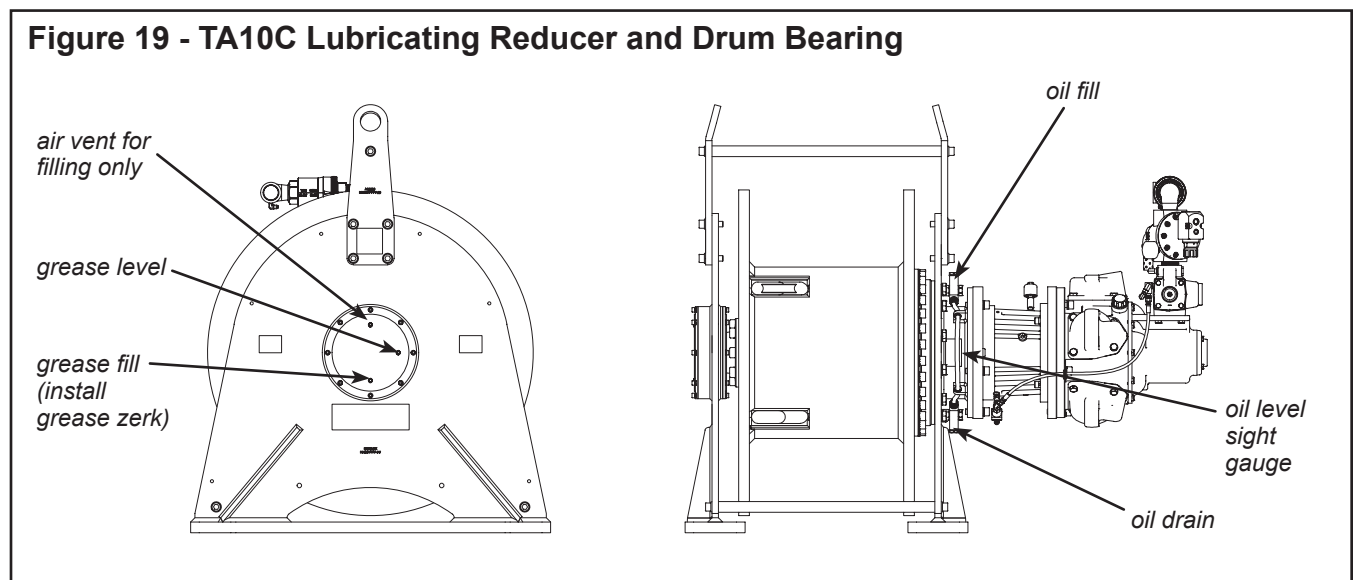

**Figure 20 - TA2.5-10C - Lubricating Motor and Brake**

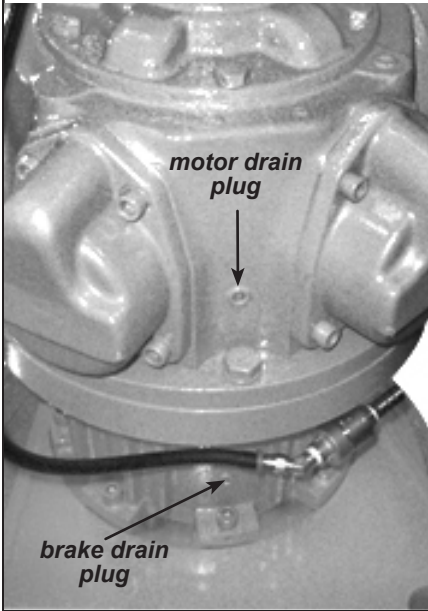

3.2.5 OIL DRAIN/FILL PROCESS

- a REMOVE fill and drain plugs.
- b ALLOW the oil to drain completely.
- c REMOVE the level plug (TA2.5C and TA5C).
- d INSTALL the drain plug.
- e FILL THE REDUCER, BRAKE, OR MOTOR with oil until the oil shows at the level plug hole or is at the recommended level in the sight tube.
- f FINISH by the installing the reducer fill and reducer level plug (if equipped) into the reducer.
- g CLEAN AREA around winch if any lubricant is on surface near winch to reduce risk to operators of winch or in area.

**Figure 21 - TA2.5C / TA5C - Lubricating the Reducer**

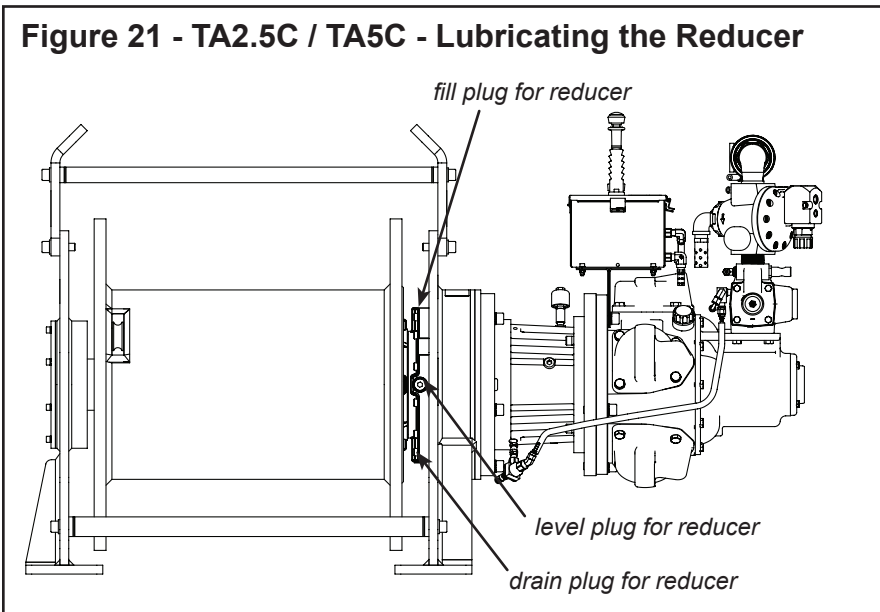

**Table 2 – Motor and Reducer Lubrication**

SERIES	OIL TYPE or EQUIVALENT	MOTOR (FL OZ)	REDUCER (FL OZ)
TA2.5C	Mobil SHC 630	38	44
TA5C	Mobil SHC 630	38	81
TA10C	Mobil SHC 630	38	308

**Table 3 – Disc Brake Lubrication**

SERIES	OIL TYPE or EQUIVALENT	DISC BRAKE (FL OZ)
TA2.5C, TA5C, TA10C	Mobil 1 Synthetic ATF	110

## 3.3 Inspecting the Equipment

### Important!

- Start an inspection program as soon as you put the winch into use.
- Appoint a qualified person to be responsible for regularly inspecting the equipment.
- Keep written records of inspection. This allows comparison with comments from previous inspections so you can see changes in condition or performance.
- Make sure all labels and plates are readable, firmly attached, free of damage and clean. Replacements are available from the factory.

### Perform frequent inspections:

- Before each operation.
- Every 3 hours during operation.
- Whenever you notice signs of damage or poor operation.

### Perform periodic inspections:

- Every 6 months except for as noted below.
- Whenever there is noticeable damage, loose fasteners, or poor operation during frequent inspection.
- Whenever you return the winch to service from storage.
- Whenever the winch has, or may have been, overloaded or shock loaded.
- Internal or inaccessible fasteners have been designed such that inspection is only required every 2 years.

### **⚠WARNING**

**Do not use damaged or malfunctioning equipment. Place an “OUT OF ORDER” sign on the winch. Do not use the winch until the sign is removed by a qualified maintenance person who has completely corrected the problem.**

Inspect the winch to detect signs of damage or poor operation before they become hazardous. See Table 4 - Inspection Checklist.

3.3.1 CONSULT APPLICABLE CODES AND REGULATIONS for specific rules on inspecting the winch and other equipment.

3.3.2 CHECK COMPONENT MANUFACTURER’S INSTRUCTIONS for inspecting the motor, brake, reducer, bearings, wire rope, and other equipment.

### 3.3.3 Instructions for Frequent Inspection

- a VISUALLY INSPECT the entire winch and all other equipment involved in the operation.
- Check all equipment for cracks, dents, bending, rust, wear, corrosion and other damage.
  - Make sure the wire rope is installed correctly and anchored securely to the drum.
  - Check the reducer, motor and disc brake for signs of lubricant leakage.
  - Make sure the entire winch is properly lubricated.
  - Make sure the motor and disc brake breather plugs are clean, open, and installed correctly.
  - Make sure mounting fasteners are tightened securely.
  - Make sure the foundation is in good condition, and capable of supporting the winch and its load under all load conditions.
  - Check air supply and connections for wear, corrosion, cuts, and other damage.
- b TEST WINCH PERFORMANCE by operating the winch with a load not exceeding the load rating.
- Listen for unusual noises, and look for signs of damage as you operate the winch.
  - Make sure the wire rope winds evenly and tightly onto the drum. If it is loose or uneven, rewind it before continuing.
  - Make sure the load moves smoothly, without hesitation or strain.
  - Make sure the winch responds to the control device. It must rotate as shown on the control labels, and it must turn off when you release the control.
  - Check the brake. Raise the load, then lower it and stop it a few feet off the ground. If the load continues to coast or creep under normal operating conditions, contact the factory.

**Completely correct all problems before continuing. Use the Troubleshooting Chart to help determine the cause of certain problems. See Table 5.**

## Frequent Wire Rope Inspection:

- Use ASME B30.7 as a guideline for rope inspection, replacement and maintenance.
- Check the wire rope, end connections and end fittings for corrosion, kinking, bending, crushing, birdcaging or other signs of damage.
- Check the number, distribution and type of visible broken wires. See paragraph 3.3.4 d and Figure 22.
- Check the wire rope for reduction of rope diameter from loss of core support, or wear of outside wires. See Figure 23.
- Take extra care when inspecting sections of rapid deterioration such as sections in contact with saddles, sheaves, repetitive pickup points, crossover points and end connections.

Figure 22 – Broken Wires

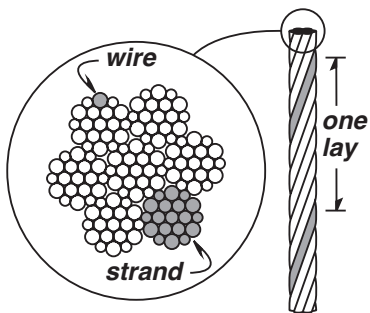

Wire rope assembly must be replaced if more than 6 wires are broken in one lay, or if more than 3 wires are broken in one strand in one lay.

## 3.3.4 Instructions for Periodic Inspection, See Table 4.

- VISUALLY INSPECT** the winch and all other equipment.
  - Disassembly may be required in order to properly inspect individual components. Contact factory for assembly/disassembly instructions. Disassembly before contacting Thern, Inc. voids all warranties.
  - Check the finish for wear, flaking, or other damage.
  - Check all equipment for cracks, dents, bending, rust, wear, corrosion and other damage. If the equipment was overloaded, or if you notice cracks and other signs of overloading and damage, promptly remove equipment from use and have it repaired or replaced. **DO NOT CONTINUE TO USE DAMAGED OR OVERLOADED EQUIPMENT OR WIRE ROPE.**
  - Check all fasteners for proper torque levels. Some fasteners will require disassembly of the winch in order to inspect and retorque NOTE: Reducer mounting fasteners and those fasteners inside the drum (i.e. reducer fasteners) need to be checked every 2 years. Contact Thern, Inc. for reducer mounting instructions on Assembly and Disassembly.
  - Check the reducer, motor and disc brake for signs of leakage.
  - Make sure the motor and brake breather plug is clean, open and installed correctly.
  - Make sure all labels and plates are readable, firmly attached, free of damage and clean. Replacements are available from the factory.
- DRAIN A SMALL AMOUNT OF LUBRICANT** from the reducer, motor and disc brake into a clean container.
  - Check the lubricant for dirt, metal particles, water, and other signs of contamination. Completely drain the reducer and motor if lubricant is contaminated.
  - Make sure the winch is completely lubricated. See section 3.2 - Lubricating the Winch.
- INSPECT THE TRAVEL LIMIT ASSEMBLY**

Note: Pneumatic rotary travel limits need periodic inspection to verify accurate operations and ensure there are no damaged or loose components.

  - REMOVE guard covering rotary limit switch.
  - ENSURE drive gears are meshing correctly and are free of damage. Visually inspect enclosure for damage such as cracks or chips.
  - REMOVE cover and check the O-ring to ensure it is not in need of replacement, and that all screws are tight. Tighten any screws that may have loosened during operation.
  - CHECK tubing connections for leaks and verify that there are no sharp bends or kinks in the tube routing.
  - REPLACE COVER and check limits for accuracy. Make adjustments to positions as necessary. See section 1.8 - Setting Travel Limits.
- INSPECT THE WIRE ROPE** according to the wire rope manufacturer's recommendations, or follow accepted industry standards for wire rope inspection.



**Figure 23 – Rope Diameter**

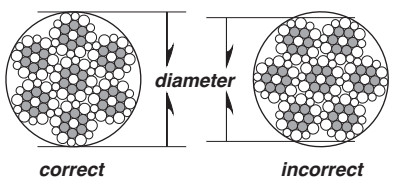

*The wire rope assembly must be replaced if the diameter measures less than the minimum diameter at any point.*

wire rope size	minimum diameter
up to 5/16 in	19/64 in (.2969 in)
up to 1/2 in	15/32 in (.4843 in)
up to 3/4 in	45/64 in (.7031 in)
up to 1-1/8 in	1 1/16 in (1.0625 in)
up to 1-1/2 in	1 13/32 in (1.4062 in)

**Figure 24 – Load Hook Inspection**

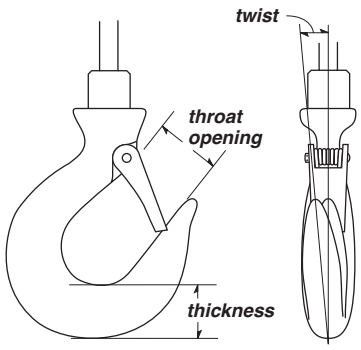

*The wire rope assembly must be replaced if the throat opening is 15% wider than nominal, if the thickness is 10% less than nominal, or if the hook is twisted 10° or more.*

- Always wear protective clothing when handling wire rope.
  - Check the entire length of wire rope for bent wires, crushed areas, broken or cut wires, corrosion, and other damage. Carefully inspect areas that pass over sheaves or through roller guides.
  - Note the location and concentration of broken wires. Replace wire rope if more than 6 wires are broken in one lay, or more than 3 wires are broken in one strand in one lay. See Figure 22.
  - Make sure the load hook or other device is securely attached to the wire rope, and the wire rope where it is attached is not frayed, corroded, broken, or otherwise damaged.
  - Measure the throat opening, thickness, and twist of the hook. Replace the hook if it shows signs of damage. See Figure 24.
  - Make sure hook latch opens without binding and closes when released.
  - Check the anchor holes in the drum and the surrounding area for signs of wear or distortion.
- e MOVE THE DRUM with your hands. Check for excessive movement indicating worn or loose gears or bearings. Excessive movement is caused by overloading or overheating, and is a sign that your application may require a larger power winch. Disassemble the winch if necessary. Inspect gears, keys, bearings, seals, and shafts for wear, distortion, and other damage.
- f PLACE enough weight to keep the wire rope straight and tightly drawn.
- Measure the diameter of the wire rope, especially in areas where wear is noticeable. Replace the wire rope if the diameter measures below the minimum diameter at any point. See Figure 23.
- g INSPECT THE FOUNDATION AND RIGGING.
- Check mounting fasteners for stripped threads, wear, and other damage.
  - Check the foundation for cracks, corrosion, and other damage.
- h TEST WINCH PERFORMANCE by operating the winch with a load equal to the load rating.
- Listen for unusual noises, and look for signs of damage as you operate the winch.
  - Make sure the wire rope winds evenly and tightly onto the drum. If it is loose or uneven, rewind it before continuing.
  - Observe the rotating drum, look for signs of loose or misaligned bearings.
  - Make sure the winch responds to the control device. It must rotate as shown on the control labels, and it must turn off when you release the control.
  - Make sure the load moves smoothly without hesitation or strain.
  - Check the brake. Raise the load, then lower it and stop it a few feet off the ground. If the load continues to coast or creep under normal operating conditions, contact the factory.
- i DISCONNECT AIR SUPPLY and inspect equipment.
- Check air supply and connections for wear, corrosion, cuts and other damage.
- j CONNECT AIR SUPPLY.

**Completely correct all problems before continuing. Use the Troubleshooting Chart to help determine the cause of certain problems. See Table 5.**

---

## 3.4 Repairing the Winch

**Important!**

- It is your responsibility to determine when to replace parts. When considering whether to continue using a part or to replace it, remember that replacing it is the best way to avoid further equipment damage.
- Replace spring pins, retaining rings, and oil seals whenever the winch is disassembled for inspection or repair.
- Appoint a qualified person to be responsible for all repairs to the equipment.
- Turn off air system and depressurize air lines before performing any maintenance.

- 3.4.1 GET FACTORY AUTHORIZATION for all repairs. Unauthorized repairs will void the warranty, and may lead to damage or failure of the winch.
- 3.4.2 REPLACE DAMAGED OR POORLY OPERATING PARTS with Thern repair parts.
- 3.4.3 REFINISH AREAS where the paint is worn or flaking. A good finish helps to protect against corrosion and weather damage.
  - a REMOVE THE FINISH from damaged areas, down to the bare metal.
  - b CLEAN THE AREA thoroughly.
  - c REPAINT with a high quality primer and finishing coat.
- 3.4.5 TO ORDER REPAIR PARTS, contact your local dealer. Include the following information when ordering:
  - model number (**See Figure 1**)
  - **serial number** (or code number) (**See Figure 1**)
  - part number
  - date purchased, and from whom
  - description of what happened, or what is wrong
  - your name and return address

## 4.1 Transporting the Winch

### Important!

- Keep a record of what you ship and when you send it.

**Figure 25 – Maintaining Sling Angles**

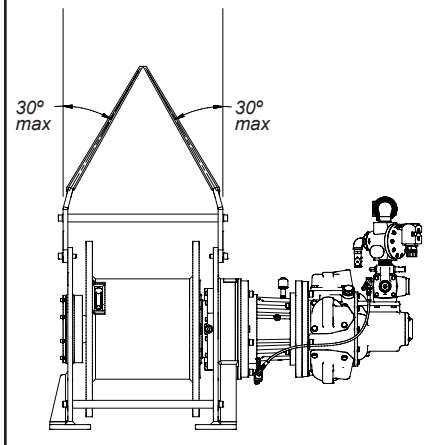

- 4.1.1 USE LIFTING EYES to properly locate winch during installation. Lifting shall not take place unless lifting support bar is installed between the lifting eyes. This will help maintain control over the winch and prevent damaging winch due to sudden uncontrolled movements. When lifting winch, ensure that it remains level. If lifting eyes have been removed from winch, re-install them or contact the factory for replacement parts if not available.
- a MAINTAIN sling angles within the limitations shown in Figure 25.
- 4.1.2 REMOVE THE BREATHER PLUG and install a sealed plug to prevent the loss of lubrication during shipment.
- 4.1.3 PACK THE WINCH in an upright position for transport, using the original packaging materials, if possible.
- a FASTEN THE WINCH to a wooden base using bolts, to keep it from moving during transport.
- b SEAL THE WINCH in plastic with a desiccant to help protect it from rust, corrosion, and other damage.
- c CONSTRUCT WOODEN SIDES and top to enclose the winch in a solid protective crate.
- d PACK LOOSE PARTS in small boxes or ship separately.
- 4.1.4 INSPECT THE WINCH according to the Instructions for Periodic Inspection before installing it in a new location.

---

## 4.2 Storing the Winch

- 4.2.1 FILL THE REDUCER, DISC BRAKE AND MOTOR with lubricant, and make sure the breather plugs are clean and properly installed. Add a rust preventative for long term storage. Follow the reducer, disc brake and motor manufacturer's instructions.
- 4.2.2 SECURE THE WINCH using mounting holes in winch to bolt down, or similar process, for storage.
- 4.2.3 SEAL THE WINCH in plastic with a desiccant to help protect it from rust, corrosion, and other damage.
- 4.2.4 STORE THE WINCH upright, in a cool clean place away from corrosive chemicals and moisture.
- 4.2.5 ROTATE THE DRUM PERIODICALLY to keep bearing and gears surfaces from becoming lacquered. Release the brake to rotate the drum.
- 4.2.6 INSPECT THE WINCH according to the Instructions for Periodic Inspection before installing it for operation.
- 4.2.7 DRAIN THE REDUCER, DISC BRAKE AND MOTOR and fill with proper lubricant prior to operation. See section 3.2 - Lubricating the Winch.

**Table 4 – Inspection Checklist** *checked boxes indicate damage or problem in need of repair*

	<b>damages</b>	<b>problems</b>
<b>general</b>	<input type="checkbox"/> finish weathered, flaking, otherwise damaged <input type="checkbox"/> parts cracked, bent, rusted, worn, otherwise damaged	<input type="checkbox"/> winch jerks or hesitates during operation <input type="checkbox"/> unusual noises, other signs of malfunction
<b>fasteners</b>	<input type="checkbox"/> stripped threads, bent, worn, otherwise damaged	<input type="checkbox"/> loose, not tightened to proper torque
<b>reducer</b>	<input type="checkbox"/> gears, bearings, or shafts loose, worn, otherwise damaged <input type="checkbox"/> lubricant leakage	<input type="checkbox"/> not properly lubricated <input type="checkbox"/> lubricant contaminated
<b>wire rope</b>	<input type="checkbox"/> bent, crushed, otherwise damaged <input type="checkbox"/> broken wires, see Figure 22 replace if more than 6 wires in one lay, or 3 wires in one strand in one lay, are broken <input type="checkbox"/> diameter reduced, see Figure 23 replace if diameter is excessively worn	<input type="checkbox"/> wire rope loosely or unevenly wound  number per strand = number per lay =  diameter =
<b>end connections</b>	<input type="checkbox"/> corroded, rusted, worn, otherwise damaged	<input type="checkbox"/> not securely attached
<b>hook or other device</b>	<input type="checkbox"/> twisted, bent, worn, otherwise damaged, see Figure 24 replace if twist is 10 degrees or more replace if throat width is 15% larger than nominal replace if thickness is 10% less than nominal	<input type="checkbox"/> hook latch fails to close when released  twist = throat width = thickness =
<b>drum</b>	<input type="checkbox"/> anchor worn, distorted, otherwise damaged	<input type="checkbox"/> excessive movement or backlash
<b>motor</b>	<input type="checkbox"/> motor corroded, worn out, otherwise damaged	<input type="checkbox"/> motor is sluggish, or operates poorly
<b>brake</b>	<input type="checkbox"/> brake worn, corroded, otherwise damaged	<input type="checkbox"/> brake does not operate properly
<b>control device</b>	<input type="checkbox"/> control components corroded, worn out, otherwise damaged	<input type="checkbox"/> fails to control winch properly
<b>air supply</b>	<input type="checkbox"/> air lines cracked, cut, corroded, otherwise damaged <input type="checkbox"/> connections loose, corroded, otherwise damaged	<input type="checkbox"/> wires unprotected, obstructing traffic pressure at motor =
<b>labels and plates</b>	<input type="checkbox"/> dirty, illegible, otherwise damaged	<input type="checkbox"/> loosely attached or missing

**comments**

\_\_\_\_\_

\_\_\_\_\_

\_\_\_\_\_

\_\_\_\_\_

\_\_\_\_\_

\_\_\_\_\_

\_\_\_\_\_

\_\_\_\_\_

\_\_\_\_\_

\_\_\_\_\_

\_\_\_\_\_

\_\_\_\_\_

\_\_\_\_\_

\_\_\_\_\_

\_\_\_\_\_

authorized signature \_\_\_\_\_ date \_\_\_\_\_

### Table 5 – Troubleshooting Chart

Contact the factory for assembly/disassembly instructions. Disassembly before contacting Thern, Inc. voids all warranties.

problem	cause	correction
<b>motor won't run</b>	<ul style="list-style-type: none"> <li>• no air supply to winch . . . . .</li> <li>• load too heavy. . . . .</li> <li>• motor damaged. . . . .</li> </ul>	<ul style="list-style-type: none"> <li>.check air supply line connections and hoses</li> <li>.lighten load</li> <li>.repair or replace as necessary</li> </ul>
<b>winch runs slow</b>	<ul style="list-style-type: none"> <li>• improper hose or fitting size</li> <li>• load too heavy . . . . .</li> <li>• motor may be damaged . . . . .</li> <li>• bearing seized up . . . . .</li> <li>• exhaust ports restricted. . . . .</li> </ul>	<ul style="list-style-type: none"> <li>check fittings, connections for size and length. Replace parts that may restrict air flow. Inspect air line filter. Make sure both exhaust ports are not restricted.</li> <li>.lighten load</li> <li>.inspect and replace as necessary</li> <li>.inspect and replace as necessary</li> <li>.remove cap and install mufflers</li> </ul>
<b>motor runs, drum doesn't turn</b>	<ul style="list-style-type: none"> <li>• loose or broken gear keys or splines . . . . .</li> <li>• loose, stripped or broken gears . . . . .</li> </ul>	<ul style="list-style-type: none"> <li>.inspect and replace as necessary</li> <li>.inspect and replace as necessary</li> </ul>
<b>motor tries to turn but can't</b>	<ul style="list-style-type: none"> <li>• unit overheated . . . . .</li> <li>• load too heavy. . . . .</li> <li>• motor may be damaged . . . . .</li> <li>• insufficient air supply. . . . .</li> <li>• brake may not be released . . . . .</li> <li>• gears or bearings broken or locked . . . . .</li> </ul>	<ul style="list-style-type: none"> <li>.allow to cool</li> <li>.lighten load</li> <li>.inspect and repair as necessary</li> <li>.verify air supply pressure and volume at winch inlet meet the requirements listed</li> <li>.inspect and repair as necessary</li> <li>.inspect and replace as necessary</li> </ul>
<b>air lines freeze</b>	<ul style="list-style-type: none"> <li>• water in air supply</li> </ul>	<ul style="list-style-type: none"> <li>install or drain air system moisture traps, moisture collecting air receivers and compressor aftercoolers. After corrective actions have been taken, disconnect lines at winch inlet and purge with clean, dry air or nitrogen prior to attaching load and operating winch.</li> </ul>
<b>brake does not operate properly</b>	<ul style="list-style-type: none"> <li>• brake release lever in release position . . . . .</li> <li>• low air supply pressure on disc brake</li> <li>• brake adjusted incorrectly . . . . .</li> <li>• brake worn or damaged . . . . .</li> <li>• brake components seized up or damaged . . . . .</li> <li>• load too heavy. . . . .</li> </ul>	<ul style="list-style-type: none"> <li>.move to lock position</li> <li>ensure air pressure at the inlet to disc brake is 50 psi</li> <li>.inspect and adjust brake</li> <li>.inspect and replace as necessary</li> <li>.inspect and repair as necessary</li> <li>.lighten load</li> </ul>
<b>lubricant leakage</b>	<ul style="list-style-type: none"> <li>• worn bearings . . . . .</li> <li>• damaged oil seals or gaskets . . . . .</li> <li>• cracked or damaged reducer or motor . . . . .</li> <li>• damaged sight level tube on TA10C reducer . . . . .</li> </ul>	<ul style="list-style-type: none"> <li>.inspect and replace as necessary</li> <li>.inspect and replace as necessary</li> <li>.inspect and repair as necessary</li> <li>.inspect and repair as necessary</li> </ul>
<b>excessive end play on drive shaft</b>	<ul style="list-style-type: none"> <li>• loose or damaged keys, keyways or splines. . . . .</li> <li>• excessively worn gears. . . . .</li> </ul>	<ul style="list-style-type: none"> <li>.inspect and replace as necessary</li> <li>.inspect and repair as necessary</li> </ul>
<b>excessively worn gears or bearings</b>	<ul style="list-style-type: none"> <li>• load too heavy. . . . .</li> <li>• poor lubrication of reducer or bearings . . . . .</li> </ul>	<ul style="list-style-type: none"> <li>.lighten load</li> <li>.inspect and lubricate as necessary</li> </ul>

### Table 5 – Troubleshooting Chart

Contact the factory for assembly/disassembly instructions. Disassembly before contacting Thern, Inc. voids all warranties.

problem	cause	correction
<b>overheating</b>	• operated too long without rest. . . . .	allow to cool
	• load too heavy. . . . .	lighten load
	• poor lubrication . . . . .	inspect and lubricate as necessary
	• breather plug clogged or damaged . . . . .	clean or replace vent plug as needed
	• bearing seized up . . . . .	inspect and replace as necessary
	• low oil level in motor or reducer . . . . .	check oil levels and add or drain as necessary
	• contaminated lubrication . . . . .	drain, clean and lubricate as necessary

<b>unusual noises</b>		
high pitched squeak	• poor lubrication . . . . .	inspect and lubricate as necessary
grinding noise	• contaminated lubrication . . . . .	drain, clean and lubricate the winch
	• broken gears or bearings . . . . .	inspect and replace as necessary
knocking motor	• load too heavy. . . . .	lighten load
	• motor overheated . . . . .	allow to cool
	• damaged motor. . . . .	inspect and replace as necessary
rattling noise	• loose fasteners or set screws . . . . .	tighten all fasteners and screws
	• worn or loose band brake . . . . .	inspect and repair or tighten as necessary
heavy thump during operation	• contaminants in lubricant . . . . .	drain, clean and lubricate the winch
	• loose set screws or keys in gears or shafts . . . . .	inspect and repair as necessary
	• bearings defective. . . . .	inspect and replace as necessary

**comments**

\_\_\_\_\_

\_\_\_\_\_

\_\_\_\_\_

\_\_\_\_\_

\_\_\_\_\_

\_\_\_\_\_

\_\_\_\_\_

\_\_\_\_\_

\_\_\_\_\_

\_\_\_\_\_

\_\_\_\_\_

\_\_\_\_\_

\_\_\_\_\_

\_\_\_\_\_

\_\_\_\_\_

\_\_\_\_\_

\_\_\_\_\_

\_\_\_\_\_

\_\_\_\_\_

\_\_\_\_\_

\_\_\_\_\_

**authorized signature** \_\_\_\_\_ **date** \_\_\_\_\_

### TAC Series Load Ratings

	TA2.5C		TA5C		TA10C	
Load Rating 1st Layer	5,500 lb	2500 kg	11,000 lb	5,000 kg	22,000 lb	10,000 kg
Load Rating Mid-Drum	5,500 lb	2500 kg	11,000 lb	5,000 kg	22,000 lb	10,000 kg
Load Rating Full Drum	5,500 lb	2500 kg	11,000 lb	5,000 kg	22,000 lb	10,000 kg
Line Speed 1st Layer*	115 fpm	35.1 m/min	48 fpm	14.6 m/min	24 fpm	7.3 m/min
Line Speed Mid Drum*	121 fpm	36.9 m/min	54 fpm	16.4 m/min	28 fpm	8.5 m/min
Line Speed Full Drum*	130 fpm	39.6 m/min	59 fpm	17.9 m/min	32 fpm	9.8 m/min
Input HP	23.0 hp	17.2 kw	21.3 hp	15.88 kW	25.84 hp	19.27 kW
Stall Pull 1st Layer**	contact factory	contact factory	contact factory	contact factory	contact factory	contact factory
Pressure	83 psi	5.7 bar	75 psi	5.2 bar	85 psi	5.9 bar
Flow	700 scfm	19.8 m3/min	700 scfm	19.8 m3/min	900 scfm	25.5 m3/min
Pipe Inlet Size	1.5 NPT	-	1.5 NPT	-	1.5 NPT	-
Hose Size	1.5 in	38.1 mm	1.5 in	38.1 mm	2.0 in	50.8 mm
Minimum Design Temp	- 4° F	- 20° C	- 4° F	- 20° C	- 4° F	- 20° C

\* Line speeds are estimated values based on testing and may vary based on conditions of air supply. Speeds shown are at max line pull.

\*\* Estimated value at pressure rating on product name plate.

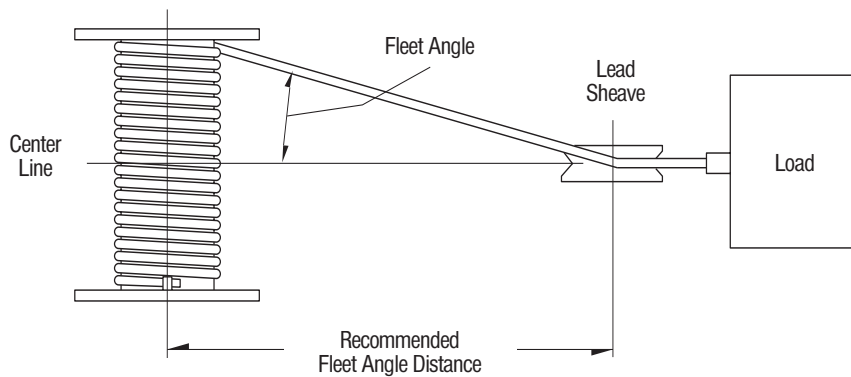

### TAC Series Minimum Fleet Angle Distances

Series	Drum Diameter		Flange Diameter		Drum Width		Fleet Angle Dist.	
	(in)	(mm)	(in)	(mm)	(in)	(mm)	(ft)	(m)
TA2.5C-12	12.75	324	21.00	533	12.00	305	20	6
TA2.5C-16	12.75	324	21.00	533	16.00	406	26	8
TA2.5C-24	12.75	324	21.00	533	24.00	610	39	12
TA5C-16	16.00	407	28.00	711	16.00	407	26	8
TA5C-24	16.00	407	28.00	711	24.00	610	39	12
TA5C-30	16.00	407	28.00	711	30.00	762	48	15
TA10C-18	20.00	508	38.00	965	18.00	457	29	9
TA10C-24	20.00	508	38.00	965	24.00	610	39	12
TA10C-30	20.00	508	38.00	965	30.00	762	48	15
TA10C-40	20.00	508	38.00	965	40.00	1016	64	20



### TA2.5C Drum Capacities\*

Rope Diameter		Breaking Strength**		DRUM WIDTH																	
				12 in (305 mm)						16 in (406 mm)						24 in (610 mm)					
				1st Layer		Mid Drum		Full Drum		1st Layer		Mid Drum		Full Drum		1st Layer		Mid Drum		Full Drum	
(in)	(mm)	(lb)	(kg)	(ft)	(m)	(ft)	(m)	(ft)	(m)	(ft)	(m)	(ft)	(m)	(ft)	(m)	(ft)	(m)	(ft)	(m)	(ft)	(m)
5/8	16	41,200	18,688	50	16	150	45	340	102	71	21	200	60	450	137	110	32	300	91	670	205

\* Drum capacity is based on a flange clearance of at least 1.5 times the wire rope diameter with the rope at top layer.

\*\* Values based on 6x37 IWRC EIPS wire rope.

### TA5C Drum Capacities\*

Rope Diameter		Breaking Strength**		DRUM WIDTH																	
				16 in (407 mm)						24 in (610 mm)						30 in (762 mm)					
				1st Layer		Mid Drum		Full Drum		1st Layer		Mid Drum		Full Drum		1st Layer		Mid Drum		Full Drum	
(in)	(mm)	(lb)	(kg)	(ft)	(m)	(ft)	(m)	(ft)	(m)	(ft)	(m)	(ft)	(m)	(ft)	(m)	(ft)	(m)	(ft)	(m)	(ft)	(m)
3/4	19.1	58,800	26,671	72	21	310	94	690	210	120	36	470	143	1,040	317	150	45	590	180	1,300	396

\* Drum capacity is based on a flange clearance of at least 1.5 times the wire rope diameter with the rope at top layer.

\*\* Values based on 6x37 IWRC EIPS wire rope.

### TA10C Drum Capacities\*

Rope Diameter		Breaking Strength**		DRUM WIDTH																							
				18 in (458 mm)						24 in (610 mm)						30 in (762 mm)						40 in (1016 mm)					
				1st Layer		Mid Drum		Full Drum		1st Layer		Mid Drum		Full Drum		1st Layer		Mid Drum		Full Drum							
(in)	(mm)	(lb)	(kg)	(ft)	(m)	(ft)	(m)	(ft)	(m)	(ft)	(m)	(ft)	(m)	(ft)	(m)	(ft)	(m)	(ft)	(m)	(ft)	(m)						
1-1/8	28.6	130,000	58,967	62	19	310	94	680	207	91	28	410	125	910	277	120	37	510	155	1,140	348	170	52	680	207	1,520	463

\* Drum capacity is based on a flange clearance of at least 1.5 times the wire rope diameter with the rope at top layer.

\*\* Values based on 6x37 IWRC EIPS wire rope.







**Thern, Incorporated**  
5712 Industrial Park Road  
Winona, MN 55987

PH 507-454-2996  
FAX 507-454-5282

EMAIL: [info@thern.com](mailto:info@thern.com)  
[www.thern.com](http://www.thern.com)

**Thern Europe**  
Windmolen 22  
7609 NN Almelo  
Netherlands

PH +31-548-659-052

EMAIL: [europe@therneurope.eu](mailto:europe@therneurope.eu)